

TWAIN HARTE COMMUNITY SERVICES DISTRICT

WATER – SEWER – FIRE – PARK
22912 Vantage Pointe Drive, Twain Harte, CA 95383
Phone (209) 586-3172 Fax (209) 586-0424

SPECIAL MEETING OF THE BOARD OF DIRECTORS THCSD CONFERENCE ROOM 22912 VANTAGE POINTE DR., TWAIN HARTE March 21, 2023 10:00 A.M.

NOTICE: Public May Attend this Meeting In-Person.

The meeting will be accessible via ZOOM for anyone that chooses to participate virtually:

- Videoconference Link: <https://us02web.zoom.us/j/89317838544>
- Meeting ID: 893 1783 8544
- Telephone: (669) 900-6833

AGENDA

The Board may take action on any item on the agenda.

1. Call to Order

2. Pledge of Allegiance & Roll Call

3. Reading of Mission Statement

4. Public Comment

This time is provided to the public to speak regarding items not listed on this agenda.

5. New Business

- A. Discussion/action to adopt the plans and specifications for the Million Gallon Tank #2 Rehabilitation Project and authorize that it be advertised for formal bidding.
- B. Discussion/action to approve a Participation Agreement for the Sourcewell Cooperative Purchasing Program.
- C. Discussion/action to adopt Resolution #23-07 – Approving a Fiscal Year 2022-23 Sewer Fund Budget Adjustment in the Amount of \$10,000 for Lift Station Pump Repair.

6. Closed Session

- A. Liability Claims (Government Code Section 54956.95)
Claimant: Jason Karney
Agency Claimed Against: Twain Harte Community Services District

- B. Conference with Legal Counsel – Anticipated Litigation:
Significant exposure to litigation pursuant to Government Code Section 54956.9(b)
(1 case)

7. Adjourn

HOW TO VIRTUALLY PARTICIPATE IN THIS MEETING

The public can virtually observe and participate in a meeting as follows:

- **Computer:** Join the videoconference by clicking the videoconference link located at the top of this agenda or on our website. You may be prompted to enter your name and email. Your email will remain private and you may enter “anonymous” for your name.
- **Smart Phone/Tablet:** Join the videoconference by clicking the videoconference link located at the top of this agenda OR log in through the Zoom mobile app and enter the Meeting ID# and Password found at the top of this agenda. You may be prompted to enter your name and email. Your email will remain private and you may enter “anonymous” for your name.
- **Telephone:** Listen to the meeting by calling Zoom at (4669) 900-6833. Enter the Meeting ID# listed at the top of this agenda, followed by the pound (#) key.

* NOTE: your personal video will be disabled and your microphone will be automatically muted.

FOR MORE DETAILED INSTRUCTIONS, CLICK [HERE](#)

SUBMITTING PUBLIC COMMENT

The public will have an opportunity to comment before and during the meeting as follows:

- **Before the Meeting:**
 - Email comments to ksilva@twainhartecsd.com, write “Public Comment” in the subject line. In the body of the email, include the agenda item number and title, as well as your comments.
 - Mail comments to THCSD Board Secretary: P.O. Box 649, Twain Harte, CA 95383
- **During the Meeting:**
 - Computer/Tablet/Smartphone: Click the “Raise Hand” icon and the host will unmute your audio when it is time to receive public comment. If you would rather make a comment in writing, you may click on the “Q&A” icon and type your comment. You may need to tap your screen or click on “View Participants” to make icons visible.

Raise Hand Icon:  Raise Hand

Q&A Icon:  Q&A

- Telephone: Press *9 if to notify the host that you have a comment. The host will unmute you during the public comment period and invite you to share comments.
- In-Person: Raise your hand and the Board Chairperson will call on you.

* NOTE: If you wish to speak on an item on the agenda, you are welcome to do so during consideration of the agenda item itself. If you wish to speak on a matter that does not appear on the agenda, you may

do so during the Public Comment period. Persons speaking during the Public Comment will be limited to five minutes or depending on the number of persons wishing to speak, it may be reduced to allow all members of the public the opportunity to address the Board. Except as otherwise provided by law, no action or discussion shall be taken/conducted on any item not appearing on the agenda. Public comments must be addressed to the board as a whole through the President. Comments to individuals or staff are not permitted.

MEETING ETIQUETTE

Attendees shall make every effort not to disrupt the meeting. Cell phones must be silenced or set in a mode that will not disturb District business during the meeting.

ACCESSIBILITY

Board meetings are accessible to people with disabilities. In compliance with the Americans with Disabilities Act, those requiring accommodations for this meeting should notify the District office 48 hours prior to the meeting at (209) 586-3172.

WRITTEN MEETING MATERIALS

If written materials relating to items on this Agenda are distributed to Board members prior to the meeting, such materials will be made available for public inspection on the District's website:

www.twainhartecsd.com



Board Meeting Agenda Item Summary

March 21, 2022

ITEM #:	05A	ITEM TYPE:	<input type="checkbox"/> Discussion <input type="checkbox"/> Action <input checked="" type="checkbox"/> Both
SUBJECT:	Discussion/action to adopt the plans and specifications for the Million Gallon Tank #2 Rehabilitation Project and authorize that it be advertised for formal bidding.		
RELATION TO STRATEGIC PLAN:	<input checked="" type="checkbox"/> N/A <input type="checkbox"/> Advances Goal/Objective #'s: <u>1, 2</u>		

RECOMMENDED ACTION:

Adopt plans and specifications for the Million Gallon Tanks #2 Rehabilitation Project (Project) and authorize that it be advertised for formal bidding.

SUMMARY:

The District owns and operates two 1-million gallon water storage tanks. These tanks are used to meet water treatment requirements and are critical to providing water storage for drinking, firefighting, and emergencies.

Tank inspections in 2018 revealed that the roof rafters in both tanks had experienced significant erosion and had twisted underneath heavy snow loads, leaving the tank roof at risk of failure in extreme storm events. In response to this finding, the District advertised a construction contract to rehabilitate both tanks. After receiving bids that were much higher than anticipated, the District was only able to rehabilitate one of the tanks. Rehabilitation was completed in 2019.

In 2022, the District was awarded a grant to fully fund rehabilitation of the remaining tank – Million Gallon Tank #2. Plans and specifications have been prepared for the Project. Project work generally includes:

- Replacement of the tank roof with an exterior rafter roof system that is much less subject to corrosion.
- Tank appurtenance upgrades to meet safety standards – guardrail, climber safety device, ladder improvements, etc.
- New cathodic protection system.
- Recoating of tank interior and exterior.

Per California Contract Code Section 22039, the Project must be advertised for formal bids and the project documents must be adopted by the District Board.

FINANCIAL IMPACT:

The Million Gallon Tank #2 Rehabilitation Project is completely funded by a \$1.275 million Urban and Multi-Benefit Drought Grant through the Department of Water Resources. The grant does not require any match.

ATTACHMENTS:

- Project Documents for the Million Gallon Tank #2 Rehabilitation Project

**TWAIN HARTE COMMUNITY SERVICES DISTRICT
PROJECT DOCUMENTS FOR**

MILLION GALLON TANK #2 REHABILITATION

**DISTRICT PROJECT
200-57-0002**

TWAIN HARTE COMMUNITY SERVICES DISTRICT

22912 Vantage Pointe Drive
Twain Harte, CA 95383

PROJECT DOCUMENTS

for construction of

DISTRICT PROJECT 200-57-0002

MILLION GALLON TANK #2 REHABILITATION

Approved for Construction:



Tom C. Trott, P.E.
General Manager

Eileen Mannix
Board President

March 2023

**TABLE OF CONTENTS
PROJECT DOCUMENTS**

PART I	NOTICE INVITING BIDS
PART II	INSTRUCTIONS TO BIDDERS
PART III	BID FORMS
PART IV	CONTRACT AND BOND
PART V	GENERAL CONDITIONS
PART VI	SPECIAL CONDITIONS
PART VII	TECHNICAL SPECIFICATIONS
PART VIII	PROJECT DRAWINGS
PART IX	APPENDIX

**PART I
NOTICE INVITING BIDS**

**MILLION GALLON TANK #2 REHABILITATION
PROJECT 200-57-0002**

NOTICE IS HEREBY GIVEN THAT the Board of Directors of the Twain Harte Community Services District (District), Twain Harte, California, invites and will receive sealed bids for furnishing all labor, equipment, materials, and services specified for the construction of Twain Harte Community Services District Project 200-57-0002, Million Gallon Tank #2 Rehabilitation Project, in conformance with the Contract.

The work generally consists of upgrading appurtenances, replacing the roof and roof structure and recoating the interior and exterior of a one million gallon welded steel water tank and other related items as specified within the Project Documents. **The engineer's estimated construction cost for construction is \$1,196,000.**

A mandatory pre-bid meeting to discuss the Project will be held on Tuesday, April 11, 2023, at 10:00 a.m., local time, at the Project site – 23363 Mountain Drive, Twain Harte, CA 95383.

The District will receive bids at its receptionist area until 3:00 p.m., local time, Friday, April 21, 2023, at 22912 Vantage Pointe Drive, Twain Harte, California, at which time and place, in the District's Board Meeting Room, accepted bids will be publicly opened and declared aloud by the Secretary of the District, and before the General Manager, or his representatives. Bids may also be mailed to 22912 Vantage Pointe Drive, Twain Harte, CA 95383 so long as they are received prior to the above bid time. **NO LATE BIDS WILL BE ACCEPTED.**

Project Documents, addenda (if any) are available for viewing without charge through the District website at www.twainhartecsd.com and may be examined or obtained at the District's offices at 22912 Vantage Pointe Drive, Twain Harte, California, from 8:00 a.m. to 4:00 p.m., Monday through Friday. The bid results will be available on the District website after the bid opening.

Copies of the Project Documents and addenda may be obtained at the District's reception area or by calling the District at (209) 586-3172. A complete set of Project Documents on CD is available at no cost; each complete paper set of Project Documents is available for a nonrefundable fee of \$20. Payment must be made at the time the documents are obtained in the form of a check (payable to Twain Harte Community Services District) or cash.

Inquiries regarding further information about the Project may be directed to Tom Trott, General Manager, (209) 586-3172 or ttrott@twainhartecsd.com.

Inquiries regarding directions to the District office and the location of the pre-bid meeting may be directed to the District's receptionist at (209) 586-3172.

All bidders and subcontractors to bidders must be registered and qualified to perform public work pursuant to Section 1725.5 of the California Labor Code, subject to limited legal exceptions under California Labor Code Section 1771.1.

Notice is hereby given that, pursuant to Part 7, Chapter 1, Article 2, Section 1770 et. seq. of the Labor Code of the State of California, the successful bidding contractor and its subcontractors shall

pay their labor forces not less than the general prevailing rate of per diem wages as determined by the State of California Director of Industrial Relations, and travel and subsistence pay as such are defined in applicable collective bargaining agreements filed in accordance with Section 1773.8 of said Labor Code, for work needed and performed on this Project. Said determinations, in effect at the time of publishing this notice, are available at the above identified District office, or may be reviewed or examined by going to www.dir.ca.gov. It shall, pursuant to the provisions of Section 1773.2 of said Labor Code, be a requirement of the work for the successful bidding contractor to post and maintain a copy of said wages' determination at the Project site throughout duration of the work. Pursuant to California Labor Code Section 1771.4, this Contract is subject to compliance monitoring and enforcement by the California Department of Industrial Relations.

Bids to receive consideration must be signed by the bona fide prime contractor who proposes to undertake the work and who is properly licensed in accordance with the Contractor's License Law as provided beginning at Section 7000 of the Business and Professions Code of the State of California. The license classification(s) required for the work are as follows: **Class A and Class C33**. The Bidder shall have the required license(s). Each bid submitted (hard copy) must be on the forms furnished herein and in accordance with California Public Contract Code section 20683 must be accompanied by cash, a certified or cashier's check made payable to the District or Bidder's bond for an amount not less than ten percent (10%) of the aggregate total bid. A form bidder's bond is included in this bid packet. Pursuant to California Code of Civil Procedures Section 995.311, the District will verify all bonds for this Project are issued and executed by a California admitted surety.

The Contractor shall be allowed to substitute securities for any monies withheld to ensure performance under this Contract pursuant to Section 22300 of the California Public Contract Code.

The District Board of Directors reserves the right to reject any or all bids for the work and waive any non-material irregularities or omissions in the bids received.

Dated at Twain Harte, California, March 21, 2023.

Kimberly Silva, Board Secretary
Twain Harte Community Services District

PART II INSTRUCTIONS TO BIDDERS

INDEX

<u>Section</u>	<u>Title</u>
1	Preparation and Submission of Bids
2	Examination of Documents and Explanation to Bidders
3	Site Inspection and Conditions
4	Addenda to the Project Documents
5	Registration of Contractors
6	Schedule of Bid
7	Not Used
8	Comparison of Bids
9	Bidder's Statement of Subcontractors
10	Qualification of Bidders
11	Certification of Completion Requirements
12	Bid Security
13	Bidder's Modification and Withdrawal of Bids
14	Bid Opening and Award of Contract
15	Relief of Bidders
16	Bonds
17	Nondiscrimination in Employment
18	Agreement to Assign (Bidders)
19	Project Documents to Successful Bidder
20	Bid Protests

PART II INSTRUCTIONS TO BIDDERS

SECTION 1 – PREPARATION AND SUBMISSION OF BIDS

Bids shall be prepared on the forms included in Part III, Bid Forms. All bid forms shall be properly executed and all blank spaces shall be filled in. Any modifications to Bidder-supplied information shall be initialed by the Bidder. Failure to comply with these requirements may, at the discretion of the District, be grounds for rejection of the bid.

Any changes by the Bidder to the District-printed bid forms may, at the discretion of the District, be grounds for rejection of the bid.

All forms in Part III, Bid Forms shall be submitted in their entirety in a sealed envelope. The sealed “Bid” envelope shall be in the District’s possession by the time stipulated in the Notice Inviting Bids, Part I. Partial or incomplete bids will not be considered. Bids shall be in strict conformity with Parts I, II, and III for District Project 200-57-0002 and any Addenda thereto.

Each bid shall be enclosed in a sealed envelope distinctly marked “Bid” and bearing the District’s project number, title as given, and the name and address of the Bidder. Bids shall either be (1) delivered in person at the Twain Harte Community Services District, 22912 Vantage Pointe Drive, Twain Harte, California, during normal business hours, being 8 a.m. to 4 p.m., Monday through Friday, or, (2) mailed to “Twain Harte Community Services District, 22912 Vantage Pointe Drive, Twain Harte, CA 95383, Attention: Secretary of the District” by the time and date restrictions listed in Part I, Notice Inviting Bids.

Where “days” is used in the Project Documents it shall mean calendar days unless stated otherwise.

Each bid shall show the full legal name and business address of the Bidder, including street address if it differs from its mailing address, and shall be signed with the usual signature of the person or persons authorized to bind the Bidder and shall be dated. Bids by a partnership or joint venture shall list the full names and addresses of all partners or joint ventures. The state of incorporation and corporate number shall be provided. The name of each signatory shall be typed or otherwise clearly imprinted below each signature where requested. When requested by the District, satisfactory evidence of the authority of any signatory on behalf of the Bidder shall be furnished.

The preparation of a bid shall be by and at the expense of the Bidder.

Bids shall be firm for sixty (60) days from and after the stated closing time, or until a Contract is fully executed by the District and a Bidder, whichever is earlier.

SECTION 2 – EXAMINATION OF DOCUMENTS AND EXPLANATION TO BIDDERS

The Project Documents consist of Notice Inviting Bids (Part I), Instructions to Bidders (Part II), Bid Forms (Part III), Contract and Bonds (Part IV), General Conditions (Part V), Special Conditions (Part VI), Technical Specifications (Part VII) and Project Drawings (Part VIII).

Any Bidder planning to submit a bid is responsible for examining with appropriate care the complete Project Documents and all Addenda, and is also responsible for informing itself with respect to all conditions, which might in any way affect the cost or the performance of any work. Failure to do so will be at the sole risk of the Bidder, and no relief can be given for errors or omissions by the Bidder.

All questions relative to the Contract prior to the issuance of the Notice of Award shall be directed to Tom Trott, Twain Harte Community Services District, 22912 Vantage Pointe Drive, Twain Harte, CA 95383.

Should the Bidder find discrepancies in or omissions from the Project Documents, or should the intent or meaning of the documents appear unclear, the Bidder shall at once notify the District of such findings. Questions received less than ten (10) days prior to the date for opening of the bids may not be answered. If the Bidder asks a question within five (5) days prior to the date for opening of the bids, the Bidder shall notify the District in writing of such question before the opening of the bids. The Bidder making notifications shall be solely responsible for their timely receipt by the District. Should the Bidder find patent ambiguities in the Project Documents, the Bidder shall at once notify the District of such findings in writing prior to opening of the bids. Replies to such notification of patent ambiguities may be made in the form of Addenda, which will be issued simultaneously to all persons who have obtained a copy of the Project Documents from the District. Failure of the Bidder awarded the Contract to notify the District of such patent ambiguity shall eliminate any and all recourse, including time extensions and Contract price adjustments the Bidder may have, against the District occurring as a result or arising out of such patent ambiguity.

The Bidder, by submission of its bid, confirms it has familiarized itself with the Project Documents and has found them fit and sufficient for the purpose of preparing its bid.

Copies of the Project Documents preliminary engineering and geotechnical reports (if any), are available for examination without charge during normal business hours (8 a.m. – 4 p.m., Monday through Friday) at the office of the:

Twain Harte Community Services District
22912 Vantage Pointe Drive
Twain Harte, CA 95383

At the time each Bidder obtains a copy of the Project Documents, it shall designate the address to which Addenda are to be sent. Such address shall be a street address. If the Bidder obtains the Project Documents online, the Bidder shall provide such address via email to the Project Manager at ttrott@twainhartecsd.com. Post office boxes alone are not acceptable. The Bidder shall also supply the telephone number, fax number, and email address.

SECTION 3 – SITE INSPECTION AND CONDITIONS

In addition to examination of the Project Documents, each prospective Bidder shall become fully informed regarding all existing and expected conditions and matters, which could affect any work or performance of any work.

The Bidder shall investigate and acquaint itself with the nature and location of work and the general and local conditions, and particularly, but without limitation, with respect to the following: those affecting transportation, access, disposal, handling, and storage of materials; availability and quality of labor, water, and electric power; availability and condition of roads; climatic conditions and seasons; river hydrology and river stages; physical conditions at the work sites and the Project

areas as a whole; topography and ground surface conditions; equipment and facilities needed preliminary to and during performance of the Contract; and all other matters that can in any way affect performance of the Contract. The failure of the Bidder to acquaint itself with any applicable condition will not relieve it from the responsibility for properly estimating either the difficulties or the costs of successfully performing the Contract.

Where the District has made investigations of tank conditions in areas where work is to be performed under the Contract, such investigations are made only for the purpose of study and design. The use of such investigations, which is presented in the form of an Inspection Report, shall be at the sole risk of the Bidder. The Inspection Reports in these Project Documents are provided for the benefit of Bidders, and Bidders shall assume all risks concerning use of the Inspection Reports in preparing their bids. The Bidder shall make whatever other reasonable investigations as are necessary to determine to the Bidder's satisfaction, the character and amount of work to be performed.

The District assumes no responsibility whatsoever in respect to the sufficiency or accuracy of the Inspection Reports, the records thereof, or of the interpretations set forth therein or made by the engineer thereof; and there is no warranty or guaranty, either expressed or implied, that the conditions indicated by such investigations or records thereof are representative of those existing throughout such areas, or any part thereof, or that unforeseen development may not occur, or that materials other than, or in proportions different from those indicated, may not be encountered.

All Project work is located on property owned by the District. If access to the District's property is desired, arrangements must be made one working day in advance of planned access by contacting the District's job-site representative, Lewis Giambruno, at telephone number (209) 586-4988 or lgiambruno@twainhartecsd.com.

Any failure to fully investigate the sites or the foregoing conditions shall not relieve the Bidder from responsibility by estimating properly the difficulty or cost of successfully performing any work. Neither the District nor any of the District's representatives or agents assumes any responsibility for any verbal representation regarding all existing and excepted site conditions.

SECTION 4 – ADDENDA TO THE PROJECT DOCUMENTS

The District may modify any provision or part of the documents at any time prior to three (3) days before closing time, provided that the closing time set forth in Part I, Notice Inviting Bids, may be extended by the District at any time prior to said closing time. Such revisions, if any, will be in the form of Addenda, which will be issued as set forth in this Part II, Section 2, Examination of Documents and Explanation to Bidders.

Contractor failure to properly acknowledge all Addenda issued (including if none) may, at the discretion of the District, be grounds for rejection of the bid. This acknowledgement shall be provided by completing and signing the form included in Part III, Bid Forms, Section 1, Bid, herein. Each Bidder shall submit this acknowledgement as a part of its bid, but in no circumstances will the acknowledgement be accepted subsequent to the closing time for bids.

SECTION 5 – REGISTRATION OF CONTRACTORS

All Bidders and their Subcontractors must be registered and qualified to perform public work pursuant to Section 1725.5 of the California Labor Code. Bids will not be accepted nor any contract entered into without proof that the Bidder and its subcontractors are registered with the California

Department of Industrial Relations to perform public work pursuant to California Labor Code Section 1725.5, subject to limited legal exceptions.

All Bidders shall have the required license(s) under the provisions of Chapter 9, Division 3, of the Business and Professions Code of the State of California to do the type of work contemplated in the Project and shall be skilled and regularly engaged in the general class or type of work called for under the Contract.

Each Bidder shall set forth in its bid the number, classification, and date of expiration of such license(s).

SECTION 6 – SCHEDULE OF BID

The quantities included in the bid are estimates of the work to be completed.

Bids shall be prepared on the form contained in Part III, Bid Forms, Section 2, Schedule of Bid. The total bid shall constitute full compensation for furnishing all materials and doing all work in the Contract. Bids must be provided for both Base Bid items and Additive Bid Items.

No substitution of materials, methods, or listed alternatives not specified in the Specifications shall be permitted.

SECTION 7 – NOT USED

SECTION 8 – COMPARISON OF BIDS

Bids will be compared on the basis of the total bid stated for the Base Bid in Part III, Section 2, Schedule of Bid. Additive Bid Items must also be completed and, at the option of the District, may be added to the value of the Base Bid to arrive at a total contract value after comparison of the Base Bids. Additive Bid Items will not be used for initial comparison of bids.

For the purpose of initial evaluation of bids, the following will be utilized in resolving arithmetic discrepancies and conflicts found on the face of the bidding schedule as submitted by Bidders:

- a. In case of discrepancy between unit price and extended price, the unit price will govern and will be used to correct the extension of unit prices.
- b. Apparent errors in addition of lump-sum and extended prices will be corrected.
- c. If no monetary symbol (\$ or ¢) is entered with a unit price, lump sum, or extension, a dollar sign (\$) will be assumed to be the Bidder's intent.

The District will recalculate the total bid based on the resolution of any arithmetic discrepancies and conflicts found. The lowest bid will be determined after any required recalculations.

Any bid that, in the opinion of the District, is so unbalanced between the various Contract items as to be detrimental to the best interests of the District will be rejected.

SECTION 9 – BIDDER'S STATEMENT OF SUBCONTRACTORS

In the form entitled Section 4, Bidder's Statement of Subcontractors, provided within Part III of this Project Manual, and pursuant to Section 4100 et seq. of the Public Contract Code, the Bidder shall submit the name, California State License Board (CSLB) license number, city, and state of the place of business of each subcontractor who will perform work or labor or render service to the prime contractor in or about the construction of the work or improvement, or a subcontractor licensed by the State of California who, under subcontract to the prime contractor, specially fabricates and installs a portion of the work or improvement according to the Project Documents, in an amount in excess of one-half of one percent (½%) of the bid total as set forth in the Schedule of Bid, Part III, Section 2. The prime contractor shall indicate the portion that will be done by each such subcontractor for each such portion as is defined by the subcontractor in its bid.

Failure to list subcontractors in Part III, Bid Forms, Section 4, Bidder's Statement of Subcontractors, is an express statement by the Bidder that it will perform that portion of the work with its own forces. The prime contractor may not substitute any person or subcontractor for a listed subcontractor without first obtaining written permission of the District's General Manager pursuant to provisions of Section 4107 of the Public Contract Code.

SECTION 10 – QUALIFICATION OF BIDDERS

Each Bidder shall submit with its bid an experience statement, substantially in the form included herein as Part III, Bid Forms, Section 7, Bidder's Statement of Experience.

A qualified bidder shall have a minimum five (5) years of experience ***specializing in tank fabrication and submersion service industrial coating for the water industry***. The bidder shall provide qualifications of the applicator and references listing at least three (3) projects completed in the past three (3) years.

If Bidder is a corporation, it shall submit its state of incorporation and corporate number in addition to its business address; if a partnership or joint venture, full names of all partners or joint venturers shall be given in the form included herein as Part III, Bid Forms, Section 1, Bid.

The District expressly reserves the right to reject any bid if it determines that the Bidder's business and technical organization, financial resources, safety information, plant and equipment to be used in performing work, or lack of successful experience in performing similar work is such that it is not in the District's best interest to accept the Bidder's bid.

Contractors or subcontractors who have been determined to have violated any public work laws and who are declared ineligible to perform work on public works projects by the Labor Commissioner as set forth in the Labor Code of the State of California, Section 1777.1 or 1777.7, are ineligible to bid or be awarded a contract for any public works project or to perform work as a subcontractor on a public works project.

SECTION 11 – CERTIFICATION OF COMPLETION REQUIREMENTS

By signing Part III, Bid Forms, Section 1, Bid, the Bidder acknowledges acceptability of the construction time frame as set forth in Part IV, Contract and Bonds, Section 1, Contract, "Time of Performance." The time specified for this work shall be deemed to start from the receipt of the Notice to Proceed. Contractor must submit a reasonable construction schedule describing how the Contractor will meet the construction time frame requirements.

SECTION 12 – BID SECURITY

No bid will be considered unless it is accompanied by bid security in the form of cash, a certified check or a cashier's check, payable to the order of the Twain Harte Community Services District, for a sum not less than ten percent (10%) of the bid total as set forth in the Bidder's Schedule of Bid, Part III, Section 2, or a Bidder's bond in the same amount executed as surety by a corporation acceptable to the District and authorized to issue such surety bond in the State of California. Such bond shall be in conformity with the form included as Section 9 of Part III, Bidder's Bond, of the Project Documents.

Upon an award to the lowest bidder, the security of an unsuccessful bidder shall be returned in a reasonable period of time, but in no event shall that security be held by the District beyond 60 days from the time the award is made.

SECTION 13 – BIDDER'S MODIFICATION AND WITHDRAWAL OF BIDS

A Bidder may, without prejudice to itself, modify or withdraw its bid by written request, provided that the request is received by the District prior to the time when bids are to be received. Following withdrawal of its bid, the Bidder may submit a new bid, provided that such new bid is received prior to the stated closing time.

SECTION 14 – BID OPENING AND AWARD OF CONTRACT

Bids will be kept unopened until the time stated for opening of bids. At such time, the contents of each bid will be made public. No responsibility shall attach to the District or any of its officers, employees, or representatives for the premature opening of a bid. All Bidders or their authorized representatives are invited to be present at the bid opening.

After opening the bids and prior to award of the Contract, the District will review the bids submitted and make a determination of the responsiveness of bids received. If the District Board of Directors or General Manager determines any bid to be nonresponsive, it reserves the rights to reject any or all bids. The District reserves the rights to reject any or all bids and to waive any non-material irregularities or omissions in bids received.

The successful Bidder will be notified in writing by the District of the Award of Contract as soon as practical and within twenty (20) days after opening of bids. Accompanying the District's Notice of Award will be the Contract, in duplicate, which the successful Bidder will be required to sign and return together with the Performance Bond, Payment Bond, and the required number of copies of insurance certificates and endorsements to the District within ten (10) days following receipt of such Notice of Award. The District will promptly determine whether such Contract, bonds, and insurance certificates and endorsements are acceptable, and upon such determination will forward a fully signed copy of the Contract to the successful Bidder. The District may issue a Notice to Proceed at any time prior to or after forwarding the Contract. The failure of any Bidder to whom the District may award the Contract as aforesaid to sign and return to the District the Contract, together with the required Performance Bond, Payment Bond, and insurance certificates and endorsements within the specified time period, shall entitle the District to declare a breach of Contract by such Bidder, to award the Contract to another Bidder, and to declare a forfeiture of the Bidder's bid security accompanying the bid.

In the event of such failure, the District will suffer damage, the amount of which is difficult, if not impossible, to ascertain; and the District shall, therefore, be entitled to retain the amount of such cashier or certified check submitted by the Bidder as bid security, or to enforce the provisions of the

Bidder's Bond in the amount thereof, as liquidated damages for such breach of Contract, as provided by applicable law.

SECTION 15 – RELIEF OF BIDDERS

Should a Bidder claim a mistake was made in its bid, the Bidder shall give the Secretary of the District written notice within five (5) business days after bid opening of the alleged mistake, and detail in said notice the circumstances under which the mistake occurred, all in accordance with Public Contract Code, Section 5103. Final determination of relief of Bidders shall be made by the District Board of Directors. Should the District Board of Directors accept the Bidder's claim for relief, the Bidder will be released from all obligations and further requirements, and its bid security will be returned as applicable.

SECTION 16 – BONDS

The Bidder to whom the Contract award is made shall, at the time of execution of the Contract, furnish to the District a Performance Bond and a Payment Bond, executed as surety by a corporation acceptable to the District and authorized to issue such surety bonds in the State of California. Such bonds shall be substantially in the form included in Sections 2 and 3, respectively, of Part IV of the Project Documents. Such Performance Bond and Payment Bond shall be for one hundred percent (100%) of the bid total as set forth in the Bidder's Schedule of Bid, Part III, Section 2. The entire cost of these bonds shall be borne by the successful Bidder.

If the surety on any bond furnished by the Contractor is declared bankrupt, or becomes insolvent, or its right to do business is terminated, or it ceases to meet the requirements of the above paragraph, the Contractor shall, within five (5) business days thereafter, notify the District and substitute another bond and surety, both of which must be acceptable to the District.

SECTION 17 – NONDISCRIMINATION IN EMPLOYMENT

Contracts for work under this Bid will obligate the Contractor and subcontractors not to discriminate in employment practices.

SECTION 18 – AGREEMENT TO ASSIGN (BIDDERS)

The Bidder's attention is directed to the provisions of Government Code Section 4552, which requires that in submitting a bid to a public purchasing body, Bidders offer to assign all rights arising from violations of antitrust regulations to the public entity if the bid is accepted. In pertinent part, Government Code Section 4552, reads as follows:

In submitting a bid to a public purchasing body, the Bidder offers and agrees that if the bid is accepted, it will assign to the purchasing body all rights, title, and interest in and to causes of action it may have under Section 4 of the Clayton Act (15 U.S.C. Sec 15) or under the Cartwright Act (Chapter 2 [commencing with Section 16700] of Part 2 of Division 7 of the Business and Professions Code), arising from the purchase of goods, materials, or services by the Bidder for sale to the purchasing body pursuant to the bid. Such assignment shall be made and become effective at the time the purchasing body tenders final payment to the Bidder.

SECTION 19 – PROJECT DOCUMENTS TO SUCCESSFUL BIDDER

The Bidder to whom award is made may obtain three (3) sets of Project Documents for the work at no extra cost. It is the Contractor's responsibility to provide its own set(s) of conformed Project Documents.

SECTION 20 – BID PROTESTS

Any protest of the proposed award of Contract to the Bidder with the lowest responsive bid must be submitted in writing to the Secretary of the District, no later than 4 p.m. of the second (2nd) business day following the date of the Bid opening. All protests shall comply with the following procedures:

1. The initial protest must contain a complete statement of the basis for the protest.
2. The protest must state the facts and refer to the specific portion of the document or the specific statute that form the basis for the protest. The protest must include the name, address, and telephone number of the person representing the protesting party.
3. The party filing the protest must concurrently transmit a copy of the initial protest to the Bidder deemed the lowest Bidder.
4. The party filing the protest must have actually submitted a Bid on the Project. A subcontractor of a party filing a Bid on this Project may not submit a Bid Protest. A party may not rely on the Bid Protest submitted by another Bidder, but must pursue its own protest in a timely manner.
5. The procedure and time limits set forth in this Section are mandatory and are the Bidder's sole and exclusive remedy in the event of a Bid Protest. The Bidder's failure to fully comply with these procedures shall constitute a waiver of any right to further pursue the Bid Protest, including filing of a challenge of the award pursuant to the California Public Contract Code, filing of a claim pursuant to the California Government Code, or filing of any other legal proceedings.
6. The District shall review all timely protests prior to formal award of the Contract. The District shall not be required to hold an administrative hearing to consider timely protest, but may do so at the option of the General Manager. At the time of the District Board of Directors' consideration of the award of the Contract, the District Board will also consider the merits of any timely protests. The District Board of Directors may either accept the protest and award the Contract to the next lowest Bidder, or reject the protest and award to the lowest Bidder.
7. These bid protest procedures shall not limit the District Board of Directors' or the General Manager's ability to reject all bids.

PART III BID FORMS

INDEX

Section	Title
1	Bid
2	Schedule of Bid
3	Bidder's License Certification and Department of Industrial Relations Registration
4	Bidder's Statement of Subcontractors
5	Noncollusion Declaration to be Executed by Bidder and Submitted With Bid
6	Bidder's Bond
7	Bidder's Statement of Experience

PART III BID FORMS

SECTION 1 – BID

In response to the Notice to Contractors, Part I, dated March 21, 2023, and in accordance with the accompanying Instructions to Bidders, Part II, the undersigned hereby proposes to the Twain Harte Community Services District, sometimes referred to as “District,” to furnish all plant, labor, technical and professional services, supervision, materials, and equipment (other than materials and equipment specified as furnished by the District), and to perform all operations necessary and required for construction of District Project 200-57-0002, Million Gallon Tank #2 Rehabilitation in accordance with the Project Documents, Parts I through VIII, inclusive, and any Addenda thereto, for District Project 200-57-0002, and at the prices stated opposite the respective items set forth in Part III, Bid Forms, Section 2, Schedule of Bid, attached hereto.

This Bid constitutes a firm offer to the District, which cannot be withdrawn for sixty (60) days from and after the date set for opening of bids, or until a contract is fully executed by the District, whichever is earlier.

The undersigned Bidder hereby certifies that it has examined and is fully familiar with all of the provisions of the Project Documents and records of investigations, where applicable; has carefully checked all of the words and figures shown on its Schedule of Bid, Part III, Section 2; has carefully reviewed the accuracy of all statements in this Bid and attachments hereto; and understands and agrees that the District will not be responsible for any errors or omissions on the part of the undersigned in preparing this Bid.

The undersigned Bidder has, by careful examination of the Project Documents and records of geotechnical investigations, where applicable, and by examination of the actual site conditions, satisfied itself as to the nature and location of all work, the general and local conditions to be encountered in the performance of any work, the requirements of the Contract, and all other matters that can in any way affect the work or the cost thereof.

If awarded the Contract, the undersigned agrees to execute and deliver to the District within ten (10) days after receipt of District’s Notice of Award, the Contract and the necessary Performance Bond, Payment Bond, and insurance certificates and endorsements.

Attached hereto and by this reference incorporated herein and made a part of this Bid are the following, which have been completed and executed by the undersigned Bidder:

- Part III, Section 2 - Schedule of Bid
- Part III, Section 3 - Bidder’s License Certification and Department of Industrial Relations Registration
- Part III, Section 4 - Bidder’s Statement of Subcontractors
- Part III, Section 5 - Noncollusion Declaration to be Executed by Bidder and Submitted With Bid
- Part III, Section 6 - Bidder’s Bond
- Part III, Section 7 - Bidder’s Statement of Experience

Enclosed herewith is a bid security in the form of a Bidder's Bond in favor of, or a certified check or a cashier's check payable to Twain Harte Community Services District, or cash in an amount not less than ten percent (10%) of the amount of the Bid total as set forth in the Schedule of Bid, Part III, Section 2, which shall be and remain the property of the District in the event of failure of the undersigned to execute and deliver the Contract and to furnish the necessary bonds and insurance certificates and endorsements in accordance with Part IV, Contract and Bonds. It is further understood by the undersigned that such failure will cause substantial injury to the District, including delay in its construction program, which injury is not easily reduced to monetary terms; and it is, therefore, agreed that the amount of the Bidder's Bid security is proper to be considered as liquidated damages for such injury and will be retained by the District in the event of such a failure.

The undersigned Bidder certifies that it is now registered with the Department of Industrial Relations (DIR) to do public work pursuant to California Labor Code Section 1725.5. The District reserves the right to require proof of registration.

The undersigned Bidder acknowledges receipt, understanding, and full consideration of the following Addenda:

ADDENDA NO(S). _____
(Indicate none if no Addenda issued)

BIDDER:

Name of Company

Business Address

Phone

Email

By: _____
Authorized Signature

Date

Name: _____
Print

Corporate Number
(if Bidder is a Corporation)

Title: _____

State of Incorporation: _____

(If person executing on behalf of a Corporation is not the President or Vice President, evidence of authority to sign on behalf of Corporation must be attached.)

If Joint Venture

The undersigned certify that they have full authority to sign this Bid on behalf of the Joint Venture named above as Bidder.

Name of Joint Venture

By: _____
Authorized Signature

By: _____
Signature

Name: _____
Print

Name: _____
Print

Title: _____

Title: _____

Date: _____

Date: _____

(Submit statement explaining the nature of the individual entities that comprise the Joint Venture and evidence of authority of individuals who sign this Bid to do so on behalf of the Joint Venture.)

Joint Venture License No.: _____

Date of Expiration: _____

Classification: _____

SECTION 2 – SCHEDULE OF BID

Unit Price Schedule of Prices for Construction of the Million Gallon Tank #2 Rehabilitation, in accordance with the Project Documents. The Bidder shall provide an amount in numbers for each item listed below (see Part II, Instructions to Bidders). Failure to comply with these requirements may be grounds for finding the bid nonresponsive.

BASE BID

Item No.	Item Description	Quantity	Unit	Unit Price	Total Price
1	MOBILIZATION AND CONSTRUCTION COORDINATION for the lump-sum (LS) price of	1	LS	\$_____	\$_____
2	REPLACE TANK ROOF for the lump-sum (LS) price of	1	LS	\$_____	\$_____
3	NEW GUARDRAIL, ROOF HATCH, ROOF VENT, LEVEL GAUGE, AND ROOF FALL PROTECTION SYSTEM for the lump-sum (LS) price of	1	LS	\$_____	\$_____
4	NEW CLIMBERS SAFETY DEVICE for the lump-sum (LS) price of	1	LS	\$_____	\$_____
5	NEW LOW SECTION OF CAGED EXTERIOR LADDER AND DOOR for the lump-sum (LS) price of	1	LS	\$_____	\$_____
6	INTERIOR COATINGS for the lump-sum (LS) price of	1	LS	\$_____	\$_____
7	EXTERIOR COATINGS for the lump-sum (LS) price of	1	LS	\$_____	\$_____
8	WELDED PATCHES for the per each (EA) price of	16	EA	\$_____	\$_____
9	DEMOBILIZATION for the per each (LS) price of	1	LS	\$_____	\$_____
10	NEW CATHODIC PROTECTION SYSTEM for the per each (LS) price of	1	LS	\$_____	\$_____

\$ _____
TOTAL BASE BID IN NUMBERS

TOTAL BASE BID IN WORDS

SECTION 3 – BIDDER'S LICENSE CERTIFICATION AND DEPARTMENT OF INDUSTRIAL RELATIONS REGISTRATION

Pursuant to the Business and Professions Code of the State of California, Section 7030:

"Contractors are required by law to be licensed and regulated by the Contractor's State License Board. Any questions concerning a contractor may be referred to the Registrar, Contractor's State License Board, 3132 Bradshaw Road, Sacramento, California, Mailing Address: P.O. Box 26000, Sacramento, California 95826."

By executing its bid, Bidder certifies that it is now licensed in accordance with the provisions of the Contractor's License Law of the State of California, and license information is as follows:

License Number – Class A: _____

License Expiration – Class A: _____

License Number – Class C33: _____

License Expiration – Class C33: _____

Pursuant to California Labor Code section 1725.5, a contractor shall be registered to be qualified to bid on, be listed in a bid proposal, subject to the requirements of Section 4104 of the Public Contract Code, or engage in the performance of any public work contract.

By executing its bid, Bidder certifies that it is now registered in accordance with the provisions of California Labor Code section 1725.5, and has received the following number:

DIR Registration Number: _____

SECTION 4 – BIDDER'S STATEMENT OF SUBCONTRACTORS

The undersigned Bidder submits herewith a list of subcontractors the Bidder proposes to employ on the work. Said subcontractors will each perform work in an amount greater than one half of one percent (½%) of the total bid. This list shall include the proper firm name, their license number and class, their DIR registration number, city and state of each subcontractor, and the portion of the work to be done by each subcontractor with the understanding that failure to name such subcontractors shall be witness that the Contractor shall have agreed to perform such portion of the work; and that the Contractor shall not subcontract said portion of the work; and if a subcontractor is listed, there shall be no substitution of that subcontractor without first obtaining written permission of the District Board of Directors pursuant to the provisions of Section 4107 of the Public Contract Code. The Contractor shall list only one subcontractor for each portion of the work to be done as defined by the Contract.

Portion of Work to be Done	Subcontractor Name	Contractor License Number	DIR Registration Number	Place of Business (City/State)

SECTION 5 – NONCOLLUSION DECLARATION TO BE EXECUTED BY BIDDER AND SUBMITTED WITH BID

State of California)
) ss.
County of _____)

_____, being first duly sworn, deposes and says that he or she is _____ of _____, the party making the foregoing Bid that the Bid is not made in the interest of, or on behalf of, any undisclosed person, partnership, company, association, organization, or corporation; that the bid is genuine and not collusive or sham; that the Bidder has not directly or indirectly induced or solicited any other Bidder to put in a false or sham bid, and has not directly or indirectly colluded, conspired, connived, or agreed with any Bidder or anyone else to put in a sham bid, or that anyone shall refrain from bidding; that the Bidder has not in any manner, directly or indirectly, sought by agreement, communication, or conference with anyone to fix the bid price of the Bidder or any other Bidder, or to fix any overhead, profit, or cost element of the bid price, or of that of any other Bidder, or to secure any advantage against the public body awarding the Contract of anyone interested in the proposed Contract; that all statements contained in the Bid are true; and, further, that the Bidder has not, directly or indirectly, submitted his or her bid price or any breakdown thereof, or the contents thereof, or divulged information or data relative thereto, or paid, and will not pay, any fee to any corporation, partnership, company association, organization, bid depository, or to any member or agent thereof to effectuate a collusive or sham bid.

By: _____
Authorized Signature

Name: _____
Print

Company

Date

SECTION 9 - BIDDER'S BOND

We, _____, as Principal, and _____, as Surety, are firmly held and bound unto the Twain Harte Community Service District, a community services district organized and existing under the laws of the State of California, sometimes referred to as the District, in the sum of \$_____ (which is a sum not less than ten percent (10%) of the amount of the accompanying Bid total) for the payment of which we bind ourselves, our heirs, executors, administrators, successors, and assigns jointly and severally, firmly by these presents.

THE CONDITION OF THIS OBLIGATION IS SUCH THAT, WHEREAS, the Principal has submitted to the District the accompanying Bid under a public Notice to Contractors Inviting Sealed Bids for District Project Million Gallon Tank #2 Rehabilitation, at 23363 Mountain Drive, Twain Harte, CA.

NOW, THEREFORE, if the accompanying Bid of the Principal is accepted and award be made by the District to the Principal; and if the Principal withdraws said Bid within the period specified in said Bid during which period said Bid cannot be withdrawn, or if the Principal shall fail, refuse, or neglect for any reason whatsoever within ten (10) days after receipt from the District of Notice of Award of the Contract to enter into the Contract with the District in accordance with the Principal's Bid and the Instructions to Bidders for said Project, and to give bond with good and sufficient surety, and to furnish the insurance certificates and endorsements as stated in said Bid and the Instructions to Bidders for said Project, then the sum guaranteed by this Bond is forfeited to the District.

It is agreed between Principal and Surety that such failure or neglect would result in injury to District, which is impracticable or extremely difficult to fix, and that such sum is considered by Principal and Surety as liquidated damages for such injury.

In the event suit is brought upon this Bond by the District and judgment is recovered, the Surety or Sureties shall pay all costs incurred by the District in such suit, including attorneys' fees to be fixed by the court.

Date

Company Name

Principal (Authorized Signature)

Business Address

City

State

ACKNOWLEDGEMENT OF PRINCIPAL'S SIGNATURE:

<p>A notary public or other officer completing this certificate verifies only the identity of the individual who signed the document to which this certificate is attached, and not the truthfulness, accuracy, or validity of that document.</p>	
<p>State of California } County of _____ } ss</p> <p>On _____ before me _____, a Notary Public, personally appeared _____ Name(s) of Signer(s)</p> <hr/> <p>who proved to me on basis of satisfactory evidence to be the person(s) whose name(s) is/are subscribed to the within instrument and acknowledged to me that he/she/they executed the same in his/her/their authorized capacity(ies) and that by his/her/their signature(s) on the instrument, the person(s) or the entity upon behalf of which the person(s) acted, executed the instrument.</p> <p>I certify under PENALTY AND PERJURY under the laws of the State of California that the foregoing paragraph is true and correct.</p> <p>WITNESS my hand and official seal</p> <p>_____ Signature of Notary</p>	<p>CAPACITY CLAIMED BY SIGNER</p> <p><input type="checkbox"/> INDIVIDUAL(S)</p> <p><input type="checkbox"/> CORPORATE OFFICER(S) _____ Title(s)</p> <p><input type="checkbox"/> PARTNER(S)</p> <p><input type="checkbox"/> ATTORNEY-IN-FACT</p> <p><input type="checkbox"/> TRUSTEE(S)</p> <p><input type="checkbox"/> OTHER _____ Describe</p> <p><input type="checkbox"/> SUBSCRIBING WITNESS (for) _____ _____ _____</p> <p>SIGNER IS REPRESENTING:</p> <p>Name(s) of Person(s) or Entity(ies) _____ _____ _____</p>

Date

Company Name

Surety (Authorized Signature)

Business Address

City

State

ACKNOWLEDGEMENT OF SURETY'S SIGNATURE:

<p>A notary public or other officer completing this certificate verifies only the identity of the individual who signed the document to which this certificate is attached, and not the truthfulness, accuracy, or validity of that document.</p>	
<p>State of California } County of _____ } ss</p>	<p style="text-align: center;">CAPACITY CLAIMED BY SIGNER</p> <p><input type="checkbox"/> INDIVIDUAL(S)</p> <p><input type="checkbox"/> CORPORATE OFFICER(S) _____ Title(s)</p> <p><input type="checkbox"/> PARTNER(S)</p> <p><input type="checkbox"/> ATTORNEY-IN-FACT</p> <p><input type="checkbox"/> TRUSTEE(S)</p> <p><input type="checkbox"/> OTHER _____ Describe</p> <p><input type="checkbox"/> SUBSCRIBING WITNESS (for) _____ _____ _____</p> <p style="text-align: center;">SIGNER IS REPRESENTING:</p> <p>Name(s) of Person(s) or Entity(ies) _____ _____ _____</p>
<p>On _____ before me _____, a Notary Public, personally appeared _____ Name(s) of Signer(s)</p>	
<p>who proved to me on basis of satisfactory evidence to be the person(s) whose name(s) is/are subscribed to the within instrument and acknowledged to me that he/she/they executed the same in his/her/their authorized capacity(ies) and that by his/her/their signature(s) on the instrument, the person(s) or the entity upon behalf of which the person(s) acted, executed the instrument.</p>	
<p>I certify under PENALTY AND PERJURY under the laws of the State of California that the foregoing paragraph is true and correct.</p>	
<p style="text-align: center;">WITNESS my hand and official seal</p> <p style="text-align: center;">_____ Signature of Notary</p>	

SECTION 7 – BIDDER'S STATEMENT OF EXPERIENCE

The undersigned Bidder submits, as a part of its Bid, the following statements as to its experience qualifications. The Bidder certifies that all statements and information set forth below are true and accurate. FAILURE TO COMPLETE THE FORM, AND/OR FAILURE TO PROVIDE INFORMATION FOR THE MINIMUM NUMBER OF PROJECTS MAY CAUSE BIDDER'S BID TO BE REJECTED AS NONRESPONSIVE.

A qualified bidder shall have minimum five (5) years of experience ***specializing in tank fabrication and submersion service industrial coating for the water industry.*** The bidder shall provide specific project details for at least three (3) such projects that Bidder has completed in the past three (3) years.

Years of specialized experience: _____

PROJECT TITLE AND DESCRIPTION OF QUALIFIED EXPERIENCE	PERFORMED FOR		
	AGENCY	CONTACT	PHONE
Project #1: Date Completed: Description:			
Project #2: Date Completed: Description:			
Project #3: Date Completed: Description:			

PART IV CONTRACT AND BONDS

INDEX

Section Title

- | | |
|---|------------------------------------|
| 1 | Contract |
| 2 | Performance Bond |
| 3 | Payment Bond |
| 4 | Workers Compensation Certification |

**PART IV
CONTRACT AND BONDS**

SECTION 1 – CONTRACT

This Contract is entered into as of the ____ day of April ____, 2023, between _____ (Contractor) and the **Twain Harte Community Services District** (District). For and in consideration of the payment to be made to Contractor, as hereinafter provided, Contractor shall perform all work specified below in accordance with all the provisions of the Contract, consisting of the following documents, which comprise the entire agreement between the District and Contractor, concerning the work, herein:

- Part I – Notice Inviting Bids
- Part II – Instructions to Bidders
- Part III – Bid Forms
- Part IV – Contract and Bonds
- Part V – General Conditions
- Part VI – Special Conditions
- Part VII – Technical Specifications
- Part VIII – Drawings
- Part IX – Appendix

1. **WORK TO BE PERFORMED:** Except as specified elsewhere in this Contract, Contractor shall furnish all plant, labor, materials, chemicals, tools, supplies, equipment, transportation, technical and professional services and supervision, and to perform all operations necessary and required to satisfactorily perform the work specified herein; all in accordance with the specifications contained herein.
2. **COMPENSATION:** As full consideration for satisfactory performance by Contractor of this Contract, the District will pay Contractor compensation in an amount not to exceed \$ _____ in accordance with the prices set forth in Section 2, Schedule of Bid, of Part III, Bid Forms, and with the payment provisions of this Contract.
3. **TIME OF PERFORMANCE:** Time is of the essence for this Contract. Contractor agrees to complete all work by **December 1, 2023, and to have the tank filled, online and operational by October 1, 2023.**
4. **AUTHORIZATION:** Both the District and Contractor do covenant that each individual executing this document by and on behalf of each part is a person duly authorized to execute contracts for that party.
5. **REPORTING REQUIREMENTS:** If Contractor is an individual or sole proprietor, Contractor must furnish its Social Security Number (SSN). If Contractor is a corporation or partnership, Contractor must furnish its Federal Employer Identification Number (FEIN). Complete the Taxpayer I.D. Number section below. If the work under this contract is subject to the payment of prevailing wages, Contractor must furnish its Department of Industrial Relations registration number.
6. **LIQUIDATED DAMAGES:** Contractor agrees to pay liquidated damages to the District at the rate of \$500 per calendar day under conditions defined in Part VI, Special Conditions, Section SC-5, Liquidated Damages.

In witness whereof, the District and Contractor have executed this Contract on the date first above written.

CONTRACTOR NAME

Contractor Address 1

Contractor Address 2

Contractor Phone

By: _____
Signature

Printed Name/Title: _____

Date: _____

Corporate Number: _____

Contractor License: _____

DIR registration: _____

Taxpayer I.D:

SSN _____ - _____ - _____

FEIN _____ - _____

TWAIN HARTE COMMUNITY SERVICES DISTRICT:

By: _____
Eileen Mannix, Board President

Date: _____

ATTEST:

By: _____
Kimberly Silva, Board Secretary

SECTION 2 – PERFORMANCE BOND

We, _____, as Principal, and _____, as Surety, are jointly and severally held and bound unto the Twain Harte Community Services District, organized and existing under the laws of the State of California, sometimes referred to as the District, in the sum of _____ Dollars (\$_____) for the payment of which we jointly and severally bind ourselves, our heirs, executors, administrators and assigns, and successors and assigns, firmly by these presents.

THE CONDITION OF THIS BOND IS SUCH THAT, WHEREAS, on the _____ day of _____, the said _____, Principal herein, executed a certain Contract with the District, by the terms, conditions, and provisions of which Contract the said _____, Principal herein, agrees to construct Million Gallon Tank #2 Rehabilitation, at 23363 Mountain Drive, Twain Harte, CA, all as set forth in said Contract, which Contract as so executed is attached hereto and by reference is incorporated herein and made a part hereof as fully for all purposes as if here set forth at length.

NOW, THEREFORE, if the Principal herein shall faithfully and truly observe and comply with the terms, conditions, and provisions of said Contract in all respects, and shall well and truly and fully do and perform all matters and things undertaken to be performed under said Contract, upon the terms set forth therein, and within the time prescribed therein, and shall indemnify the District against any direct or indirect damages that shall be claimed for injuries to persons or property during the course of any work performed by or on behalf of Principal under said Contract, and until all work under said Contract is accepted and for an additional period of one (1) year after completion and acceptance of said work by the District, and shall apply all laborers, mechanics, subcontractors, materialmen, and all persons who shall supply such Contractor or subcontractor with services or supplies for carrying on such work, and shall perform said Contract according to laws, and shall complete in a satisfactory manner all repairs or replacements resulting from or caused by defective materials and/or faulty workmanship in the prosecution of the work during the one-year warranty period, then this obligation shall be void, otherwise it shall remain in full force and effect. No prepayment or delay in payment and no change, extension, addition, or alteration of any provision of said Contract agreed to between the Principal and the District, and no forbearance on the part of the District, shall operate to relieve any Surety from liability on this Bond, and consent to make such changes, extension, additions, and alterations without further notice to or consent by any Surety is hereby given.

In the event suit is brought upon this Bond by the District and judgment is entered in its favor, the Surety or Sureties shall pay all costs incurred by the District in such suit, including attorneys' fees to be fixed by the court.

Date

Company Name

Principal (Authorized Signature)

Business Address

City

State

ACKNOWLEDGEMENT OF PRINCIPAL'S SIGNATURE:

<p>A notary public or other officer completing this certificate verifies only the identity of the individual who signed the document to which this certificate is attached, and not the truthfulness, accuracy, or validity of that document.</p>	
<p>State of California } County of _____ } ss</p> <p>On _____ before me _____, a Notary Public, personally appeared _____ Name(s) of Signer(s)</p> <hr/> <p>who proved to me on basis of satisfactory evidence to be the person(s) whose name(s) is/are subscribed to the within instrument and acknowledged to me that he/she/they executed the same in his/her/their authorized capacity(ies) and that by his/her/their signature(s) on the instrument, the person(s) or the entity upon behalf of which the person(s) acted, executed the instrument.</p> <p>I certify under PENALTY AND PERJURY under the laws of the State of California that the foregoing paragraph is true and correct.</p> <p>WITNESS my hand and official seal</p> <p>_____ Signature of Notary</p>	<p>CAPACITY CLAIMED BY SIGNER</p> <p><input type="checkbox"/> INDIVIDUAL(S)</p> <p><input type="checkbox"/> CORPORATE OFFICER(S) _____ Title(s)</p> <p><input type="checkbox"/> PARTNER(S)</p> <p><input type="checkbox"/> ATTORNEY-IN-FACT</p> <p><input type="checkbox"/> TRUSTEE(S)</p> <p><input type="checkbox"/> OTHER _____ Describe</p> <p><input type="checkbox"/> SUBSCRIBING WITNESS (for) _____ _____ _____</p> <p>SIGNER IS REPRESENTING:</p> <p>Name(s) of Person(s) or Entity(ies) _____ _____ _____</p>

Date

Company Name

Surety (Authorized Signature)

Business Address

City

State

ACKNOWLEDGEMENT OF SURETY'S SIGNATURE:

<p>A notary public or other officer completing this certificate verifies only the identity of the individual who signed the document to which this certificate is attached, and not the truthfulness, accuracy, or validity of that document.</p>	
<p>State of California } County of _____ } ss</p>	<p>CAPACITY CLAIMED BY SIGNER</p> <p><input type="checkbox"/> INDIVIDUAL(S)</p> <p><input type="checkbox"/> CORPORATE OFFICER(S) _____ Title(s)</p> <p><input type="checkbox"/> PARTNER(S)</p> <p><input type="checkbox"/> ATTORNEY-IN-FACT</p> <p><input type="checkbox"/> TRUSTEE(S)</p> <p><input type="checkbox"/> OTHER _____ Describe</p> <p><input type="checkbox"/> SUBSCRIBING WITNESS (for) _____ _____ _____</p> <p>SIGNER IS REPRESENTING: Name(s) of Person(s) or Entity(ies) _____ _____ _____</p>
<p>On _____ before me _____, a Notary Public, personally appeared _____ Name(s) of Signer(s)</p>	
<p>who proved to me on basis of satisfactory evidence to be the person(s) whose name(s) is/are subscribed to the within instrument and acknowledged to me that he/she/they executed the same in his/her/their authorized capacity(ies) and that by his/her/their signature(s) on the instrument, the person(s) or the entity upon behalf of which the person(s) acted, executed the instrument.</p> <p>I certify under PENALTY AND PERJURY under the laws of the State of California that the foregoing paragraph is true and correct.</p> <p>WITNESS my hand and official seal</p> <p>_____ Signature of Notary</p>	

SECTION 3 – PAYMENT BOND

We, _____, as Principal, and _____, as Surety, are jointly and severally held and bound unto the Twain Harte Community Services District, organized and existing under the laws of the State of California, sometimes referred to as the District, in the sum of _____ Dollars (\$_____) for the payment of which we jointly and severally bind ourselves, our heirs, executors, administrators and assigns, and successors and assigns, firmly by these presents.

THE CONDITION OF THIS BOND IS SUCH THAT, WHEREAS, on the _____ day of _____, the said _____, Principal herein, executed a certain Contract with the District, by the terms, conditions, and provisions of which Contract the said _____, Principal herein, agrees to construct Million Gallon Tank #2 Rehabilitation, at 23363 Mountain Drive, Twain Harte, CA, all as set forth in said Contract, which Contract as so executed is attached hereto, and by reference is incorporated herein and made a part hereof as fully for all purposes as if here set forth at length.

AND WHEREAS, said Contractor is required by the provisions of Sections 9550 through 9556, California Civil Code, to furnish a bond in connection with said Contract, as hereinafter set forth.

THE CONDITION OF THIS OBLIGATION IS SUCH that if said Contractor, its heirs, executors, administrators, successors, or assigns, or subcontractors, shall fail to pay any of the persons named in Section 9100 of the California Civil Code, or amounts due under the Unemployment Insurance Code with respect to work or labor performed by any such claimant, or for any amount required to be deducted, withheld, and paid over to the California Franchise Tax Board from the wages and employees of the Contractor and its subcontractors pursuant to such Contract and warranty work and labor that the Surety or Sureties will pay for the same, in an amount not exceeding the sum specified in this Bond, and also, in case suit is brought upon the Bond, a reasonable attorney’s fee, to be fixed by the court.

This Bond shall inure to the benefit of any and all of the persons named in Section 9100 of the California Civil Code as to give a right of action to such persons or their assigns in any suit brought upon this Bond in accordance with said Sections 9550 through 9556 of the California Civil Code.

In the event suit is brought upon this Bond and judgment is recovered, the Surety shall pay all costs incurred by the District in such suit, including reasonable attorney’s fees to be fixed by the court.

No prepayment or delay in payment and no change, extension, addition, or alteration of any provision of said Contract agreed to between the Contractor and the District, and no forbearance on the part of the District, shall operate to relieve any Surety from liability of this Bond, and consent to make such changes, extensions, additions, and alterations without further notice to or consent by such Surety is hereby given.

Date

Company Name

Principal (Authorized Signature)

Business Address

City

State

ACKNOWLEDGEMENT OF PRINCIPAL'S SIGNATURE:

<p>A notary public or other officer completing this certificate verifies only the identity of the individual who signed the document to which this certificate is attached, and not the truthfulness, accuracy, or validity of that document.</p>	
<p>State of California } County of _____ } ss</p> <p>On _____ before me _____, a Notary Public, personally appeared _____ Name(s) of Signer(s)</p>	<p>CAPACITY CLAIMED BY SIGNER</p> <p><input type="checkbox"/> INDIVIDUAL(S)</p> <p><input type="checkbox"/> CORPORATE OFFICER(S) _____ Title(s)</p> <p><input type="checkbox"/> PARTNER(S)</p> <p><input type="checkbox"/> ATTORNEY-IN-FACT</p> <p><input type="checkbox"/> TRUSTEE(S)</p> <p><input type="checkbox"/> OTHER _____ Describe</p> <p><input type="checkbox"/> SUBSCRIBING WITNESS (for) _____ _____ _____</p>
<p>who proved to me on basis of satisfactory evidence to be the person(s) whose name(s) is/are subscribed to the within instrument and acknowledged to me that he/she/they executed the same in his/her/their authorized capacity(ies) and that by his/her/their signature(s) on the instrument, the person(s) or the entity upon behalf of which the person(s) acted, executed the instrument.</p>	
<p>I certify under PENALTY AND PERJURY under the laws of the State of California that the foregoing paragraph is true and correct.</p> <p>WITNESS my hand and official seal</p> <p>_____ Signature of Notary</p>	<p>SIGNER IS REPRESENTING:</p> <p>Name(s) of Person(s) or Entity(ies) _____ _____ _____</p>

Date

Company Name

Surety (Authorized Signature)

Business Address

City

State

ACKNOWLEDGEMENT OF SURETY'S SIGNATURE:

<p>A notary public or other officer completing this certificate verifies only the identity of the individual who signed the document to which this certificate is attached, and not the truthfulness, accuracy, or validity of that document.</p>	
<p>State of California } County of _____ } ss</p> <p>On _____ before me _____, a Notary Public, personally appeared _____ Name(s) of Signer(s)</p> <hr/> <p>who proved to me on basis of satisfactory evidence to be the person(s) whose name(s) is/are subscribed to the within instrument and acknowledged to me that he/she/they executed the same in his/her/their authorized capacity(ies) and that by his/her/their signature(s) on the instrument, the person(s) or the entity upon behalf of which the person(s) acted, executed the instrument.</p> <p>I certify under PENALTY AND PERJURY under the laws of the State of California that the foregoing paragraph is true and correct.</p> <p>WITNESS my hand and official seal</p> <p>_____ Signature of Notary</p>	<p>CAPACITY CLAIMED BY SIGNER</p> <p><input type="checkbox"/> INDIVIDUAL(S)</p> <p><input type="checkbox"/> CORPORATE OFFICER(S) _____ Title(s)</p> <p><input type="checkbox"/> PARTNER(S)</p> <p><input type="checkbox"/> ATTORNEY-IN-FACT</p> <p><input type="checkbox"/> TRUSTEE(S)</p> <p><input type="checkbox"/> OTHER _____ Describe</p> <p><input type="checkbox"/> SUBSCRIBING WITNESS (for) _____ _____ _____</p> <p>SIGNER IS REPRESENTING:</p> <p>Name(s) of Person(s) or Entity(ies) _____ _____ _____</p>

SECTION 5 – WORKERS’ COMPENSATION CERTIFICATION

AS REQUIRED BY SECTIONS 1861 OF THE CALIFORNIA LABOR CODE

I am aware of the provisions of Section 3700 of the California Labor Code, which require every employer to be insured against liability for workers’ compensation or to undertake self-insurance in accordance with the provisions of the California Labor Code, and I will comply with such provisions before commencing the performance of the work of this Contract for District Project 200-57-0002, Million Gallon Tank #2 Rehabilitation.

Contractor: _____

By: _____

Title: _____

Date: _____

PART V GENERAL CONDITIONS

INDEX

Section	Title
GC-1	Entire Agreement
GC-2	Independent Contractor
GC-3	Authorized Representatives
GC-4	Meetings
GC-5	Notices
GC-6	Discovery of Errors, Omissions or Discrepancies
GC-7	Laws, Regulations, and Prevailing Wages
GC-8	Permits, Licenses, Easements and Taxes
GC-9	Publications
GC-10	Waiver
GC-11	Indemnity
GC-12	Patent Indemnity
GC-13	Subcontracts and Subcontractors
GC-14	Assignments
GC-15	Termination of Right to Proceed
GC-16	Optional Termination
GC-17	Suspension of Work
GC-18	Contractor-Furnished Drawings and Data
GC-19	Substitutions and Equal Alternatives
GC-20	Quality of Equipment, Materials, Products, and/or Workmanship
GC-21	Inspections and Samples
GC-22	Project Documents and Record Drawings
GC-23	Safety Requirements
GC-24	Cleaning Up
GC-25	Contaminated Soils/Materials
GC-26	Existing Utilities and Interferences
GC-27	Differing Site Conditions

- GC-28 Changes
- GC-29 Delays and Time Extensions
- GC-30 Extra Work Payment
- GC-31 Protest Procedure
- GC-32 Records and Accounts
- GC-33 Progress Payments
- GC-34 Liens and Stop Notice
- GC-35 Acceptance of Contract and Final Payment
- GC-36 Survival
- GC-37 Warranty
- GC-38 Cost-Reduction Incentive

**PART V
GENERAL CONDITIONS**

GC-1 ENTIRE AGREEMENT

This Contract embodies the entire agreement between the District and Contractor. The parties shall not be bound by or be liable for any statement, representation, promise, inducement, or understanding of any kind or nature not set forth herein. No changes, amendments, or modifications of any of the terms or conditions of the Contract shall be valid unless reduced to writing and signed by both parties.

GC-2 INDEPENDENT CONTRACTOR

Contractor represents that it is fully experienced and properly qualified to perform the class of work provided for herein, and that it is properly licensed, equipped, organized, and financed to perform such work. Contractor shall act as an independent contractor and not as the agent of the District in performing the Contract, maintaining complete control over its employees and all of its subcontractors. Nothing contained in this Contract or any subcontract awarded by Contractor shall create any contractual relationship between any such subcontractor and the District. Contractor shall perform all work in accordance with its own methods subject to compliance with the Contract.

Contractor shall employ only competent and skilled personnel to perform the work. Contractor shall, if requested to do so by the District in writing, remove from the jobsite any personnel of Contractor. Contractor is responsible for maintaining satisfactory conduct of its employees and those of its subcontractors and maintaining labor relations in such manner as shall provide for harmony among the workers.

Contractor shall comply with and shall cooperate with the District in enforcing jobsite conditions which affect the performance of the work including but not limited to starting and quitting time, smoking regulations, check-in and check-out procedures, jobsite safety regulations, and daily clean-up.

GC-3 AUTHORIZED REPRESENTATIVES

Before starting work, Contractor shall designate a competent, authorized representative acceptable to the District to represent and act for Contractor and shall inform the District in writing of the name and address of such representative together with a clear definition of the scope of his/her authority to represent and act for Contractor and shall specify any and all limitations of such authority. Contractor shall keep District informed of any subsequent changes in the foregoing. All notices, determinations, instructions, and other communications given to the authorized representative by the District shall be binding upon Contractor.

The District's representative (sometimes referred to as "District") is the District's General Manager or the General Manager's authorized designee. All questions and requests of the Contractor as to compensation (including additional compensation), interpretation of the Contract, instructions, or extensions of time, otherwise shall be submitted in writing to the District's representative for determination. The District's representative is authorized to:

1. Determine the amount, quality, acceptability, and fitness of all work, materials, and equipment required by the Contract.
2. Make the final decision on all questions that may arise as to the quality or acceptability of materials furnished and work performed and as to the manner of performance and rate of progress of the work.
3. Make the final decision on all questions that may arise as to the coordination, interpretation and acceptable fulfillment of the Contract and its plans and Specifications.
4. Make the final decision on all questions as to measurement and payment and amounts owed to the Contractor.
5. Reject defective work and materials whenever such rejection may be necessary to assure execution of the Contract in accordance with the intent of the Contract.
6. Prepare and/or issue Contract Change Orders for all authorized changes or approved extra work in the Contract.
7. Monitor Project schedules and to enforce Project schedule requirements, and to take such measures as may be necessary to maintain overall Project schedules.
8. Enforce and to make effective such decisions and orders that the Contractor fails to carry out promptly.

GC-4 MEETINGS

A preconstruction meeting will be held after the award of the Contract to review the Contractor's preconstruction submittals as required by the Contract and to discuss various safety and administrative items. The Contractor shall also be prepared to discuss the construction schedule and methods of implementing the various work items.

The District may notice other meetings at which attendance by the Contractor and subcontractors may be required.

GC-5 NOTICES

Any written notice to be given to Contractor by the District, may be delivered in person to Contractor's authorized representative or mailed to the address last given in writing by Contractor.

Notices to District:

Twain Harte Community Services District
22912 Vantage Pointe Drive
Twain Harte, CA 95383

Administrative Representative: Tom Trott, General Manager
Contract No.: 200-57-0002
Telephone: (209) 586-3172

Technical Representative: William Bellis, P.E.
Telephone: (805) 748-6726

GC-6 DISCOVERY OF ERRORS, OMISSIONS OR DISCREPANCIES

If the Contractor discovers any errors, omissions, discrepancies, or conflicts in the Contract, it shall immediately so inform the District in writing. The District will promptly clarify such matters by issuing Addenda or Change Orders. Failure or delay to act on the part of the District shall not constitute a waiver of any right afforded the District by the Contract or constitute an implied approval. Any work affected by such discoveries that is performed by the Contractor prior to authorization by the District shall be at the Contractor's risk.

Unless otherwise noted below, conflicts or inconsistencies between parts of the Contract will be resolved by the District with a Change Order or with an Addendum, if required. Addenda and Change Orders bearing the most recent date shall prevail over Addenda or Change Orders bearing earlier dates. Any reference to Addenda-changed Specifications or drawings shall be considered to have been changed accordingly.

In resolving conflicts, errors, or discrepancies, the order of precedence shall be as follows:

1. Change Orders/Addenda (most recent in time takes precedence)
2. Contract and Bond Forms
3. Technical Specifications
4. Special Conditions
5. Project Drawings
6. General Conditions
7. Instructions to Bidders
8. Bid Forms
9. Notice to Contractors

Reference specifications shall have the same order of precedence as the document in which it is referenced. For example, a reference to the District's Standard Specifications contained in the Technical Specifications will have the same order of precedence as that Technical Specification. A reference to an Appendix contained in the Technical Specifications will have the same order of precedence as that Technical Specification. If a reference specification is mentioned in more than one part of the Contract, the part with the highest order of precedence shall govern.

With reference to the Project Drawings:

1. Figures govern over scaled dimensions.
2. Project-specific drawings govern over general and typical drawings.
3. Addenda/Change Order drawings govern over Project Drawings.
4. Project Drawings govern over standard drawings.

It shall be the Contractor's responsibility to resolve any conflicts between the requirements contained on permits from other agencies and the Contract to the satisfaction of the District. When there is a conflict between the requirement(s) as specified in the Contract and as required by other agencies, the more restrictive requirement(s) shall prevail.

By execution of the Contract, the Contractor agrees that no request for additional compensation, and/or claim under Government Code Section 900 et seq. will be made against the District for any damages in excess of the aggregate sum of \$50,000 or five percent (5%) of the

construction costs (whichever is greater) for alleged damage that it or its subcontractors may suffer due to the inadequacy of the Contractor's bid on account of any alleged errors, omissions, or other deficiencies in the Contract. This limitation shall not apply to compensation for extra work authorized by the District as provided for in this Section GC-30, Extra Work Payment, and Section GC-27, Differing Site Conditions.

GC-7 LAWS, REGULATIONS, AND PREVAILING WAGES

This Contract shall be in accordance with the laws of the state of CALIFORNIA. Parties further stipulate that this Contract was entered into in the state of CALIFORNIA and the state of CALIFORNIA is the only appropriate forum for any litigation as a result of breach hereof or any questions risen herefrom.

Contractor shall keep itself fully informed of, and shall observe and comply with, all laws, ordinances, and regulations which in any manner affect those engaged or employed on any work, or the materials and equipment used in any work, or in any way affect the performance of any work, and of all orders and decrees of agencies having any jurisdiction or authority over work performed under the Contract.

Contractor shall comply with all applicable federal, state, and local laws, ordinances, rules, and regulations; and lawful orders of all authorities having jurisdiction for the safety of persons and protection of property.

If any discrepancy or inconsistency should be discovered between the Contract and any such law, ordinance, regulation, order, or decree, Contractor shall immediately report the same in writing to the District. Contractor shall be responsible for the compliance by subcontractors of all tiers with the above provisions of this Section. Contractor shall post all job site notices as required by law or regulation.

- A. Prevailing Wages: Special attention is directed to Part 7, Chapter 1, Article 2, Sections 1770 et seq. of the California Labor Code. Reference is hereby made to the provisions for minimum per diem wages contained in Part I, Notice to Contractors. . This Contract will be subject to compliance monitoring and enforcement by the California Department of Industrial Relations, pursuant to Labor Code Section 1771.4.

The Contractor and each subcontractor engaged in the work shall pay each respective employee thereof an amount not less than the general prevailing rate of per diem wages established in compliance with Section 1770 et seq. of the California Labor Code and as determined by the State of California Director of Industrial Relations to be effective and applicable for the various crafts, trades, or type of worker needed or required to execute the Contract. In accordance with Section 1770 of said Labor Code, nothing otherwise provided under Article 2 of said Labor Code shall prohibit the payment of wage rates to any worker in excess of such prevailing rates of wages as determined by the Director of the Department of Industrial Relations. However, should the Contractor or a subcontractor have a contractual relationship with workers whereby per diem rates of wages are paid in excess of such determined prevailing rates of wages, the Contractor or subcontractor shall identify and submit a certified listing of such workers and the amounts payable prior to beginning construction operations applicable thereto in accordance with this General Condition.

Failure of the Contractor or any subcontractor to certify and list workers and actual wages in excess of those effective as determined by the State of California Director of Industrial Relations shall be deemed an express statement by the Contractor or such subcontractor that actual wages shall be as determined by the Director of Industrial Relations and such will be paid all workers and be applicable to all work required and ordered under the Contract.

The possibility of labor cost increases within the periods of time established and specified for completion of the Project is one of the elements to be considered by bidding Contractors and its subcontractors. The District will not consider any increase in labor costs as a basis of a request for additional compensation for work bid as specified and shown regardless of the cause of the increase.

It is stipulated that the provisions of Article 2, Chapter 1, Part 7, Division 2 (commencing with Section 1770), of the California Labor Code, and in particular, Sections 1775 and 1776, shall be complied with. In accordance with said Section 1775, the Contractor and any subcontractor under the Contractor, shall forfeit to the District or to the Division of Labor Standards, as a penalty, up to fifty dollars (\$50) per each day or portion thereof, for each worker paid less than the prevailing rates for such work or craft in which such worker is employed for any work done under the Contract by him/her or by any subcontractor under the Contractor in violation of the provisions of the Labor Code and in particular, California Labor Code Sections 1770 to 1780, inclusive. The amount of the daily penalty shall be as determined by the Labor Commissioner in accordance with Section 1775. In addition to said penalty and pursuant to said Section 1775, the difference between the prevailing wage rates and the amount paid to each worker by the Contractor or subcontractor for each day or portion thereof for which each worker was paid less than the prevailing wage rate shall be paid to each worker by the Contractor or subcontractor.

If a worker employed by a subcontractor is not paid the general prevailing per diem wages by the subcontractor, the prime contractor or the project is not liable for any penalties unless the prime contractor had knowledge of that failure to pay specified prevailing rate of wages to those workers or unless the prime contractor fails to comply with the California Labor Code, Section 1775(b) (1)-(4).

Where prevailing wage determinations have been predetermined to change during the Contract (beyond expiration dates as indicated on the forms), the Contractor shall obtain such changes from the Prevailing Wage Unit, Division of Labor Statistics and Research, Department of Industrial Relations, 525 Golden Gate Avenue, San Francisco, California 94102, telephone (415) 557-0561, and deliver copy of such to the District.

If a Contractor or subcontractor intends to use a craft or classification not shown on the general prevailing wage determinations, the Contractor or subcontractor may be required to pay the wage rate of the craft or classification most closely related to it as shown in the general determinations effective at the time of bid opening.

- B. Payroll Records: The Contractor and subcontractor's attention is directed to the provisions of Section 1776 of the California Labor Code and to the requirements therein pertaining to the keeping, availability, and filing of accurate payroll records of all journeymen, apprentices, and other workers performing work under this Contract. The Contractor agrees to comply with the requirements of said section.

Prior to each monthly progress payment, the Contractor shall deliver to the District copies of certified payrolls of its and all subcontractors' forces performing work at the job site (or sites established primarily for the work) for labor compliance purposes and extra/force account considerations. Such records shall be kept current on an effective day or period basis. The certified payroll records shall be kept on forms provided by the Division of Labor Standards Enforcement, or shall contain the same information as the forms provided by the Division in addition to the above-listed information.

The Contractor shall also furnish the records specified in California Labor Code Section 1776, including but not limited to the certified payrolls, directly to the Labor Commissioner.

Each payroll record shall contain or be verified by a written declaration that is made under penalty of perjury stating:

1. The information contained in the payroll is true and correct;
2. The employer has complied with the requirements of California Labor Code Sections 1771, 1811, and 1815 for any work performed by its employees on the Project.

The Contractor shall inform the District of the location of the above payroll records, including the street address, city and county, and shall, within five (5) working days, provide a notice of change of location and address.

The Contractor or subcontractor has 10 days in which to comply subsequent to receipt of a written notice requesting certified payroll records. In the event that the Contractor or subcontractor fails to comply within the 10-day period, he or she shall, as a penalty to the District, forfeit one hundred dollars (\$100) for each calendar day, or portion thereof, for each worker, until strict compliance is effectuated. Upon the request of the Division of Labor Standards Enforcement, these penalties shall be withheld from progress payments then due. The Contractor is not subject to a penalty assessment pursuant to this section due to the failure of a subcontractor to comply with this section.

Any copy of records made available for inspection as copies and furnished upon request to the public or any public agency by the District shall be marked or obliterated in accordance with California Labor Code Section 1776.

Compliance with the above provisions of this Section and California Labor Code, Section 1776, shall be the responsibility of the Contractor or subcontractor. Pursuant to Labor Code Section 1771.4, Contractor is required to post all job-site notices prescribed by law or regulation that include, but are not limited to, payment of prevailing wages.

- C. Labor Discrimination: Attention is directed to Section 1735 of the Labor Code, which reads as follows:

No discrimination shall be made in the employment of persons upon public works because of race, religious creed, color, national origin, ancestry, physical disability, mental disability, medical condition, marital status, or sex of such persons, except as provided in Section 12940 of the Government Code, and every contractor for public works violating this Section is subject to all the penalties imposed for violation of this Chapter.

- D. Apprentices: The Contractor shall comply with the provisions of Sections 1777.5 and 1777.6, of the California Labor Code in regard to employment of apprentices.
- E. Work Hours: Contractor stipulates and agrees that pursuant to the provisions of Labor Code, Sections 1810 through 1815, eight (8) hours labor shall constitute a legal day's work, and no worker shall be required or permitted to work more than eight (8) hours in any one (1) calendar day and forty (40) hours in any one (1) calendar week, except as provided for under Section 1815. Nothing in this provision shall be construed to relate to wage determination or in any way affect contractual provisions related to compensation. The contractor or subcontractor shall, as a penalty to the District, forfeit twenty-five dollars (\$25) for each worker employed in the execution of the contract by the respective contractor or subcontractor for each calendar day during which the worker is required or permitted to work more than 8 hours in any one calendar day and 40 hours in any one calendar week in violation of the provisions of this article.

Notwithstanding the Labor Code provisions set forth above, pursuant to Labor Code, Section 1815, work performed by employees of Contractor in excess of eight (8) hours per day and forty (40) hours during any one (1) week shall be permitted provided that compensation shall be made for all hours worked in excess of eight (8) hours per day at not less than one and one-half (1-1/2) times the basic rate of pay.

- F. Travel: As required by Section 1773.8 of the California Labor Code, the Contractor shall pay travel and subsistence payments to each worker needed to execute the work, as such travel and subsistence payments are defined in the applicable collective bargaining agreements filed in accordance with this Section.
- G. Chemical Exposure: Contractor shall comply with Sections 12101 through 12901 of Title 22, California Administrative Code. Contractor shall warn all persons at the work site of their exposure to chemicals known to the state to cause cancer or birth defects or other reproductive harm. Contractor shall be responsible for compliance by its subcontractors with this article.
- H. Air Pollution: The Contractor shall so perform its work as not to discharge into the atmosphere from any source whatsoever smoke, dust, or other air contaminants in violation of the laws, rules, and regulations of the governmental entities having jurisdiction.
- I. Asbestos: The Contractor shall comply with all state laws and regulations regarding asbestos and asbestos-related work including, but not limited to, the provisions of California Labor Code, Sections 6501.5 through 6511.
- J. Human Remains: The Contractor's attention is directed to the provisions of Health and Safety Code, Section 7050.5, relating to the discovery of human remains. Upon any such discovery, there shall be no further excavation or disturbance of the site. The Contractor shall immediately notify the District and the Tuolumne County Sheriff-Coroner's Office of any such find and shall comply with all other applicable laws and regulations.
- K. Cultural Resources: The Contractor's attention is directed to the provisions of Health and Safety Code, Section 7050.5, and Public Resources Code, Sections 5098.5, 5097.94, 5097.98, and 5097.99, and the California Environmental Quality Act (CEQA), Appendix K, relating to the excavation, removal, destruction, injury, and defacement of historic or prehistoric ruins, burial grounds, archeological or vertebrate paleontological sites, or any

other archeological, paleontological or historical feature. The Contractor shall immediately stop work in the area of the archeological discovery and notify the District and comply with all other laws and regulations upon discovery of any such remains in the construction site. Compensation to the Contractor, if any, for lost time or changes in construction to avoid the find shall be determined in accordance with changed conditions or Change Order provisions of the Contract. The Contractor shall have no property right in such sites or features.

In the event that any Indian relics or items possessing archaeological or historical value are discovered by the Contractor or any of its subcontractors or any of their representatives or employees, the Contractor shall immediately notify the District and await the District's decision before proceeding with any work. The Contractor shall have no property right in such relics and items.

L. License: Contractor shall be licensed under the provisions of Chapter 9, Division 3, of the Business and Professions Code of the State of California to do the type of work contemplated in the Project and shall be skilled and regularly engaged in the general class or type of work called for under the Contract.

M. Agreement to Assign (Contractors and Subcontractors): Agreement to Assign (Contractors and Subcontractors): The Contractor's and subcontractors' attention is directed to the provisions of Government Code, Section 4551, which requires that, in entering into a public works contract or subcontract, contractors and subcontractors agree to assign to the purchasing body all rights arising from violations of antitrust regulations. In pertinent part, Government Code, Section 4551, reads as follows:

In entering into a public works contract or a subcontract to supply goods, services or materials pursuant to a public works contract, the contractor or subcontractor offers and agrees to assign to the awarding body all rights, title and interest in and to all causes of action it may have under Section 4 of the Clayton Act (15 U.S.C. Section 15) or under the Cartwright Act (Chapter 2 [commencing with Section 16700] of Part 2 of Division 7 of the Business and Professional Code) arising from purchases of goods, services, or materials pursuant to the public works contract or the subcontract. This assignment shall be made and become effective at the time the awarding body tenders final payment to the contractor without further acknowledgement by the party

N. Claims and Actions Against Public Entities and Employees: The Contractor's and subcontractors' attention is directed to Government Code Section 900 et seq. dealing with claims and actions against public entities and employees. Nothing contained in the Contract, including but not limited to Section GC-28, Changes, is intended to modify or remove the requirements set forth in these Government Code sections.

1. If the Contractor files any claim with the District for compensation in excess of the Contract amount or return of liquidated damages, the claim shall be in writing and include the documents necessary to substantiate the claim. Said documents may include invoices, cost breakdowns, and other documentation explaining the details of the Contractor's calculations of the amount claimed. Such claim must be filed on or before the date of final payment. Nothing in this subsection is intended to extend the time limit or supersede notice requirements otherwise provided by the Contract relating to requests for extra compensation or extensions of time. The presentation

of any claim by the Contractor shall be accompanied by a signed personal certification as set forth below.

PERSONAL DECLARATION AND CERTIFICATION OF CLAIM

I, _____, BEING THE _____ (MUST BE AN OFFICER) OF _____ (CONTRACTOR), DECLARE UNDER PENALTY OF PERJURY UNDER THE LAWS OF THE STATE OF CALIFORNIA, AND DO PERSONALLY CERTIFY AND ATTEST THAT: I HAVE THOROUGHLY REVIEWED THE ATTACHED CLAIM AND KNOW ITS CONTENTS, AND SAID CLAIM IS MADE IN GOOD FAITH; THE SUPPORTING DATA IS TRUTHFUL AND ACCURATE; THAT THE AMOUNT REQUESTED ACCURATELY REFLECTS THE CONTRACT ADJUSTMENT FOR WHICH THE CONTRACTOR BELIEVES THE DISTRICT IS LIABLE; AND, FURTHER THAT I AM FAMILIAR WITH CALIFORNIA GOVERNMENT CODE SECTION 12650, ET SEQ. PERTAINING TO FALSE CLAIMS, AND FURTHER KNOW AND UNDERSTAND THAT SUBMISSION OR CERTIFICATION OF A FALSE CLAIM MAY LEAD TO FINES, IMPRISONMENT AND/OR OTHER SEVERE LEGAL CONSEQUENCES.

Signed: _____

Date: _____

2. For claims of less than fifty thousand dollars (\$50,000), the District will respond in writing within 45 days of its receipt of the claim, or may request, in writing, within 30 days of its receipt of the claim, submission of additional documentation supporting the claim or relating to defenses or claims the District may have against the Contractor.
 - a. If such additional documentation is requested by the District, it shall be provided by the Contractor within 20 days of its receipt of the request from the District or as otherwise mutually agreed upon by the District and the Contractor.
 - b. Following the Contractor's submission of all requested additional documentation, the District will respond to the claim within 15 days or within the period of time taken by the Contractor in producing the additional documentation, whichever is longer.

3. For claims of over fifty thousand dollars (\$50,000) and less than or equal to three hundred seventy-five thousand dollars (\$375,000), the District will respond in writing within 60 days of its receipt of the claim, or may request, in writing, within 30 days of receipt of the claim, submission of additional documentation supporting the claim or relating to defenses or claims the District may have against the Contractor.
 - a. If such additional documentation is requested by the District, it shall be provided by the Contractor within 30 days of its receipt of the request or as otherwise mutually agreed upon by the District and the Contractor.
 - b. Following the Contractor's submission of all requested additional documentation, the District will respond to the claim within 30 days, or within

the period of time taken by the Contractor in producing the additional documentation, whichever is longer.

4. If the Contractor disputes the District's written response, or if the District fails to respond within the time prescribed, the Contractor may so notify the District, in writing, either within fifteen (15) days of receipt of the District's response or within fifteen (15) days of the District's failure to respond within the time prescribed, respectively, and demand an informal conference to meet and confer for settlement of the issues in dispute. Upon receiving such a demand, the District shall schedule a meet and confer conference within thirty (30) days.
5. If, following the meet and confer conference, the claim or any portion remains in dispute, the Contractor may file a claim pursuant to Chapter 1 (commencing with Section 900) and Chapter 2 (commencing with Section 910) of Part 3 of Division 3.6 of Title 1 of the Government Code. For purposes of those provisions, the running of the period of time within which a claim must be filed shall be tolled from the time the Contractor submits its written claim pursuant to paragraph 2 above until the time said claim is denied pursuant to the procedures set forth herein, including any period of time utilized by the meet and confer conference.

GC-8 PERMITS, LICENSES, EASEMENTS AND TAXES

- A. Permits and Licenses: Contractor shall, unless otherwise provided elsewhere in the Contract, at its expense, obtain all permits and licenses and pay all charges and fees necessary for the performance of the Contract, and shall give all public notices necessary for the lawful performance of the Contract.

Attention is directed to the Project Documents and to any permits that may have been acquired by or imposed upon the District that contain requirements related to performance of the work, including but not limited to encroachment permits and storm water pollution prevention. All work within public properties and rights of way shall be accomplished in conformance with any specific conditions, instructions, and/or requirements contained in permits issued by the agencies having jurisdiction over such property and rights of way.

Where permits and/or licenses require subsequent contingent permits, inspections, or other actions, the Contractor shall comply with these requirements at no additional cost to the District, except that the inspection fees charged by regulatory and/or permitting agencies shall be paid for by the District. However, if the inspection fee is due to noncompliance of the permit requirements, such inspection fee shall be paid for by the Contractor.

- B. Easements: The District may provide easements for work under the Contract. District-provided easements are shown in the Project Documents. All work within private and public properties shall be accomplished in conformance with any specific conditions, instructions, and/or requirements of the respective easements.

The District may provide additional easements for use of public or private property for working space, haul roads, and for storage of materials and equipment. District-provided easements are shown in the Project Documents. The Contractor may use such property so provided for working space, haul roads, and for storage of materials and equipment.

Should the Contractor find it necessary or advantageous to use any land, over and above that land that is provided, for any purpose whatever, the Contractor shall, at its expense, obtain a written agreement with the property owner and obtain approval from the District for the use of such land. A copy of any such agreement shall be submitted to the District prior to implementation.

Nothing in the Contract shall be construed as allowing the Contractor to make any arrangements with any person to permit occupancy or use of any land, structure, or building for any Contract purpose whatsoever, either with or without compensation, in conflict with any agreement between the District and any owner, former owner, or tenant of such land, structure, or building.

- C. Taxes: Contractor shall pay all taxes, levies, duties, and assessments of every nature due in connection with any work under the Contract, shall make any and all payroll deductions required by law, and shall indemnify and hold harmless the District from any liability on account of any and all such taxes, levies, duties, assessments, and deductions.

GC-9 PUBLICATIONS

No publications or advertisements concerning the subject matter of the Contract shall at any time be made by or on behalf of Contractor, its subcontractors, or suppliers, unless prior written authorization is obtained from the District.

No advertising signs shall be erected at the site of the work.

GC-10 WAIVER

Neither the inspection by the District, nor any order, measurement, approval, determination, decision, or certificate by the District, nor any order by the District for the payment of money, nor any payment for or use, occupancy, possession, or acceptance of the whole or any part of the work by the District, nor any extension of time, nor any other act or omission of the District shall constitute, or be deemed to be acceptance of any defective or improper work, materials, or equipment nor operate as a waiver of any requirement or provision of the Contract, nor of any remedy, power, or right of or herein reserved to the District nor of any right to damages for breach of Contract. Any and all rights and/or remedies provided for in the Contract are intended and shall be construed to be cumulative; and, in addition to each and every other right and remedy provided for herein or by law, the District shall be entitled, as a right, to a writ or injunction against any breach or threatened breach of the Contract by Contractor, by its subcontractors, or by any other person or persons.

None of the provisions of the Contract shall be considered waived by the District unless such waiver is expressly given in writing by the District. No such waiver shall be a waiver of any past or future default, breach, or modification of any of the terms, provisions, conditions, or covenants of the Contract unless expressly set forth in such waiver.

GC-11 INDEMNITY

Contractor shall indemnify, defend, and hold harmless the District and its officers, agents, servants, employees and any other District representatives, and each of them, from and against any and all suits, actions, legal or administrative proceedings, claims, demands, consequential damages, liabilities, interest, attorneys' fees, costs and expenses of whatsoever kind or nature

whether arising before or after final acceptance of the work hereunder and in any manner directly or indirectly caused, occasioned, or contributed to or claimed to be caused, occasioned, or contributed to in whole or in part by reason of any act, omission, fault, or negligence whether active or passive of Contractor, or of anyone acting under its direction, control, or on its behalf including subcontractors in connection with or incident to the performance of this Contract without limiting the generality of the foregoing, the same shall include injury to or death of any person or persons and damage to any property, regardless of where located, including without limitation the property of the District, Contractor's employees, and all other persons. Contractor's aforesaid indemnity and hold harmless agreement shall not be applicable to any liability caused by the active negligence or willful misconduct of the District or its officers, agents or employees.

Contractor shall include in each agreement with each of its subcontractors at all tiers, a provision requiring that the subcontractor indemnify the District as stated in this Section.

GC-12 PATENT INDEMNITY

The Contractor shall pay all licenses, copyrights, fees, and royalties and assume all costs incident to the use and performance of the work, or the incorporation in the work, of any invention, design, process, product, or device that is the subject of patent rights or copyrights held by others. The Contractor shall indemnify, defend, and save harmless the District, its officers, directors, employees, representatives, and agents, and each of them from and against all claims, losses, costs, damages, consequential damages, and expenses, including attorneys' fees, incurred by the District, its officers, directors, employees, representatives, and agents as a result of or in connection with any claims or actions based upon infringement or alleged infringement of any patent and/or copyright and arising out of the use of the materials, equipment, and/or products furnished under the Contract by the Contractor, or out of the processes or actions employed by, or on behalf of, the Contractor in connection with the performance of the Contract. The Contractor shall, at its expense, promptly defend against any such claim or action, whether or not well founded in fact or in law, provided that the District shall have notified the Contractor upon becoming aware of such claims or actions, and provided further that the Contractor's aforementioned obligations shall not apply to equipment, materials, and/or products furnished or specified by the District. The Contractor shall have the right, in order to avoid such claims or actions, to substitute at its expense noninfringing equipment, materials, and/or products, or to modify at its expense such infringing equipment, materials, and/or products so they become noninfringing, provided that such substituted and modified equipment, materials, and/or products shall meet all the requirements and be subject to all the provisions of the Contract.

GC-13 SUBCONTRACTS AND SUBCONTRACTORS

No subcontract shall be entered into and Contractor shall not substitute any person as subcontractor in place of a subcontractor so listed in the Contract provided that the District, at its discretion, may consent to a subcontractor substitution if (1) the subcontractor listed fails or refuses to execute a written contract, or (2) the substitution is otherwise necessary to the efficient construction of the work. In either case, Contractor shall obtain the District's prior written consent. No subcontracts at any tier shall relieve Contractor of any of its liabilities or obligations under the Contract, and Contractor agrees that it is fully responsible to the District for the acts and omissions of its subcontractors and of persons either directly or indirectly employed by them in the performance of the Contract. Contractor shall assure that each subcontractor at all tiers fully complies with the provisions of any applicable Worker's

Compensation Act or similar law having application to subcontractor's employees. Failure of Contractor or any of its subcontractors to comply with this provision will be considered as grounds for termination of the Contract at Contractor's expense in accordance with Section GC-15 Termination of Right to Proceed.

Nothing contained in the Contract shall create any contractual relationship between any subcontractor and the District.

The Contractor shall, at all times, be responsible for the safety of its subcontractors' employees at any tier and for its subcontractors' plants and equipment at any tier; and the method of prosecuting the work and shall ensure the compliance, by all subcontractors' employees at any tier, with all local, state, and federal safety regulations and the District Safety Requirements as may be applicable to the performance of the work.

The Contractor shall, at all times, be responsible for the adequacy, efficiency, and sufficiency of its subcontractor at any tier or persons employed by the subcontractors. All workers shall have sufficient knowledge, skill, and experience to properly perform the work assigned to them.

When a portion of the work that has been subcontracted by the Contractor is not being prosecuted in a manner satisfactory to the District, the Contractor shall cause such subcontractor forces to be removed immediately upon the request of the District, and such subcontractor forces shall not again be employed on the work.

Any assignment of the performance of this Contract without prior written consent of the District shall be voidable. Consent will not be given to any proposed assignment which would relieve the original Contractor or its Surety of their responsibilities under the Contract. Contractor may assign monies due or to become due it under the Contract, to the extent permitted by law, and such assignment will be recognized by the District, if written notice thereof is given to the District at least ten (10) working days before a payment is due, but any assignment of monies shall be subject to all proper set-offs in favor of the District and to all deductions or retentions provided for in the Contract and particularly all money withheld, whether assigned or not, shall be subject to being used by the District for the completion of the work in the event that Contractor should be in default therein or for the payment of claims or liens.

GC-14 ASSIGNMENTS

No assignment of any performance of work under this Contract shall be made by the Contractor, its heirs, executors, administrators, or successors without prior written consent of the District. Consent for any proposed assignment will not be considered that would, by any instrument, relieve the original Contractor or its Surety of the responsibilities under the Contract.

The Contractor may assign monies due or to become due under the Contract, to the extent permitted by law, and such assignment will be recognized by the District, if written notice thereof is given to the District at least ten (10) days before a payment is due. Any assignment of monies shall, however, be subject to all proper set-offs in favor of the District and to all deductions provided for in the Contract. All monies withheld, whether assigned or not, shall be subject to being used by the District for the completion of the work in the event that the Contractor should be in default therein or for the payment of claims or liens against the work from any source.

GC-15 TERMINATION OF RIGHT TO PROCEED

If Contractor should refuse or fail, except in cases for which extension of time is provided, to supply enough properly skilled workers, proper equipment and proper appliances or proper materials, or if it should fail to make prompt payments to subcontractors or for material or labor, or disregard laws, ordinances, or the instructions of the District, or otherwise be guilty of a substantial violation of any provision of this Contract, then the District may without prejudice to any other right or remedy, serve written notice upon Contractor and Surety, if any, of the District's intention to terminate the performance of Contractor, such notices to contain the reasons for such termination, and unless within seven (7) calendar days after the serving of such notice upon Contractor and Surety, if any, such cause shall cease and satisfactory arrangement for correction shall be made, the performance of Contractor shall cease and terminate. In the event of any such termination, or should Contractor be adjudged as bankrupt, or if it should make a general assignment for the benefit of its creditors, or if a receiver should be appointed on account of its insolvency, the District shall serve notice thereof upon Contractor and Surety, if any, and the Surety shall have the right to perform the Contract; provided, however, that if the Surety does not commence performance thereof within seven (7) calendar days from the date of service of notice of termination upon the Surety, the District may take possession of the premises and of all materials, tools, equipment, and appliances thereon and finish the work by whatever method the District may deem expedient. In such case, Contractor shall not be entitled to receive any further payment until the work is finished. If the unpaid balance of the Contract price shall exceed the expense of finishing the work, including compensation for additional managerial and administrative services, such excess shall be paid to Contractor. If such expense shall exceed such unpaid balance, Contractor and Surety, if any, shall pay the difference to the District. The expense incurred by the District as herein provided, and the damage incurred through Contractor's default, shall be certified by the District. Service of any notices hereunder shall be deemed complete upon the deposit in the United States mail, postage prepaid, addressed to the address of Contractor and Surety, if any, as shown on records on file with the District.

Said termination shall be without prejudice to any other remedies available to the District.

Upon receipt of any such written notice of termination of right to proceed, Contractor shall, at its expense, for that work affected by any such termination:

- A. Assist the District in making an inventory of all materials and equipment in storage at the site, enroute to the site, and on order from suppliers.
- B. Assign to the District subcontracts, supply contracts, and equipment rental agreements all as designated by the District.
- C. Remove from the site all construction materials, equipment, and plant listed in said inventory other than such construction materials, equipment, and plant which are designated in writing by the District to be used by the District in completing such work.

GC-16 OPTIONAL TERMINATION

Including, but not limited to, provisions for termination in the event of national emergency under Section 4410 et. seq. of the Government Code of the State of California, the District may, at its

option, cancel and terminate the Contract in whole or in part at any time by written notice thereof to Contractor, whether or not Contractor is in default.

Upon any such cancellation and termination, Contractor shall waive any claims for damages, including loss of anticipated profits, on account thereof, but as the sole right and remedy of Contractor and the District, the District shall pay Contractor in accordance with subparagraph B., below, provided, however, that the provisions of the Contract, which by their very nature survive final acceptance under the Contract, shall remain in full force and effect after such cancellation and termination to the extent provided in such provisions.

- A. Upon receipt of any such notice, Contractor shall, unless the notice requires otherwise:
 - 1. Immediately discontinue work on the date and to the extent specified in the notice.
 - 2. Place no further orders or subcontracts for materials, services, or facilities, other than as may be necessary or required for completion of such portion of work under the Contract that is not terminated.
 - 3. Promptly make every reasonable effort to obtain cancellation upon terms satisfactory to the District of all orders and subcontracts to the extent they relate to the performance of work terminated.
 - 4. Assist the District as specifically requested, in writing, in the maintenance, protection, and disposition of property acquired by the District under the Contract.

- B. Upon any such termination, the District will pay to Contractor an amount determined in accordance with the following (without duplication of any item):
 - 1. All amounts due and not previously paid to Contractor for work completed in accordance with the Contract prior to such notice, and for work thereafter completed as specified in such notice.
 - 2. The cost of settling and paying claims arising out of the termination of work under subcontracts or orders as provided in subparagraph A.3., above.
 - 3. The reasonable costs incurred pursuant to subparagraph A.4., above.
 - 4. Any other reasonable costs incidental to such termination of work.
 - 5. The foregoing amounts shall include a reasonable sum, under all of the circumstances, as profit for any work performed by Contractor.

GC-17 SUSPENSION OF WORK

The District may, at any time and in its sole discretion, for the District's convenience, by notice in writing to the Contractor, suspend the performance of all or any portion of the work being or to be performed under the Contract. Work that is suspended shall not be resumed until the District issues a written notice to resume suspended work. Upon issuing the notice to suspend work, the District will designate the amount and type of plant, labor, and equipment to be committed to the Project. During the period of suspension, the Contractor shall use its best efforts to utilize its plant, labor, and equipment in such a manner as to minimize the costs associated with suspension.

- A. Upon receipt of any notice to suspend work, the Contractor shall, unless the notice requires otherwise:

1. Immediately discontinue work on the date and to the extent specified in the notice; and
 2. Place no further orders or subcontracts for material, services, or facilities with respect to suspended work other than as required in the notice; and
 3. Promptly make every reasonable effort to obtain suspension of all orders, subcontracts, and rental agreements to the extent they relate to performance of work suspended upon terms satisfactory to the District; and
 4. Unless otherwise specifically stated in the notice, the Contractor shall continue to protect and maintain the Project, including those portions of work that have been suspended.
- B. As full compensation, the Contractor will be reimbursed for the following costs, reasonably incurred, without duplication of any item, to the extent that such costs directly result from such suspension of work:
1. A standby charge to be paid to the Contractor during the period of suspension of work, which standby charge shall be sufficient to compensate the Contractor for keeping, to the extent required in the notice, its organization and equipment committed to the Project in a standby status.
 2. All reasonable costs associated with mobilization and demobilization of the Contractor's plant, forces, and equipment.
 3. An equitable amount to reimburse the Contractor for the cost of maintaining and protecting that portion of the Project upon which work has been suspended.
 4. If the costs associated with subsequently performing work is increased or decreased as a result of any such suspension of work, an equitable adjustment reflecting either an increase or decrease in such cost will be established by Change Order in accordance with Section GC-28, Changes.

Upon receipt of notice to resume suspended work, the Contractor shall immediately resume the suspended work to the extent required in the notice. The Contractor shall also submit a revised construction schedule for the District's review and approval.

In cases where other governmental agencies or authorities suspend the performance of the work, and such suspension is not due to the failure of the Contractor to comply with the requirements of the Contract, the suspension will be considered a suspension for convenience by the District and the provisions of this Section shall apply.

Notwithstanding the provisions for convenience stated above, the District may partially or entirely suspend the work for an indefinite period of time for the failure of the Contractor to comply with the Contract. Under such suspension, the Contract completion date will not be extended and the Contractor shall not be entitled to recover resulting costs or damages including, but not limited to, acceleration costs.

GC-18 CONTRACTOR-FURNISHED DRAWINGS AND DATA

Contractor shall promptly submit within the time specified at its own expense all submittals, shop drawings and details required by the plans and specifications. The District's favorable review shall be obtained before any such items are manufactured or used in the work. The

favorable review of drawings by the District shall apply in general design only and shall in no way relieve Contractor from responsibility for errors or omissions contained therein. Favorable review by the District shall not relieve Contractor of its obligation to meet safety requirements and all other requirements of laws.

Submittals and coordination are the responsibility of Contractor; this responsibility shall not be delegated in whole or in part to subcontractors or suppliers. Any designation of work "by other," shown on submittals, shall mean that the work will be the responsibility of Contractor rather than the subcontractor or supplier who has prepared the shop drawings.

Submittals shall be prepared in such form that data can be identified with the applicable specification paragraph. The data shall demonstrate clearly compliance with the project drawings and specifications and shall relate to the specific equipment to be furnished. Where manufacturer's standard drawings are employed, they shall be marked clearly to show what portions of the data are applicable to this project.

Review of shop drawing submittals by the District has as its primary objective the completion for the District of a project in full conformance with the project drawings and specifications, unmarred by field corrections, and within the time provided. In addition to this primary objective shop drawing review as a secondary objective will assist Contractor in its procurement of equipment that will meet all requirements of the project drawings and specifications, will fit the structures detailed on the drawings, will be complete with respect to piping, electrical, and control connections, will have the proper functional characteristics, and will become an integral part of a complete operating facility. Acceptance of shop drawings and submittals does not constitute a change order to the Contract requirements.

Within ten (10) business days after receipt by the District of three (3) hard copies and one (1) PDF copy each of Contractor's submissions and all appurtenant data required for their review, the appropriate number of copies will be returned to Contractor with one of the following notations:

1. Resubmittal not required; correction, if any noted.
2. Correct and resubmit; corrections noted.

Returned copies of drawings marked with notation "1" authorize Contractor to proceed with the operations covered by such returned copies, provided that such operations shall be subject to the comments, if any, shown on such returned copies

Returned copies of drawings marked with notation "2" shall be corrected, as necessary and required, and shall be submitted in the same manner as before.

Submittals which do not have all the information required to be submitted, including deviations, are not acceptable and will be returned without review.

When submittals are favorably reviewed, the District will retain two (2) copies and will return all other copies to Contractor. When submittals are not favorably reviewed, the District will retain only one (1) copy and will return all others to Contractor.

It is considered reasonable that Contractor shall make a complete and acceptable submission to the District at least by the second submission of data. The District reserves the right to deduct

monies from payments due Contractor to cover additional costs of the District's review beyond the second submission.

Favorable review by the District will not constitute acceptance by the District of any responsibility for the accuracy, coordination, and completeness of the shop drawings or the items of equipment represented on the drawings. Accuracy, coordination, and completeness of shop drawings shall be the sole responsibility of Contractor, including responsibility to backcheck comments, corrections, and modifications from the District's review before fabrication.

Supplemental, specific requirements for shop drawings and details are contained in the applicable technical sections of these specifications.

Copies of schedules and shop drawings submitted to the District for review shall be such as to provide two (2) for the District's files, and such additional copies as Contractor may desire for its own office files and/or for distribution by it to subcontractors or vendors. Exceptions will be noted in specific sections of this Contract.

All submittals and supporting data, catalogs, and schedules, shall be submitted as the instruments of Contractor, who shall be responsible for their accuracy and completeness. These submittals may be prepared by Contractor, subcontractors, or suppliers, but Contractor shall ascertain that submittals meet all of the requirements of the Contract while conforming to structural, space, and access conditions at the point of installation. Contractor shall check all submittals before submitting them to the District.

The District shall check and review schedules, drawings, etc., submitted by Contractor only for general design conformance with the concept of the project and compliance with the information given in the Contract.

Shop drawings shall not be used to order products' fabrication or delivery for construction or installation unless submitted to and favorably reviewed by the District.

Acceptance by the District of any drawings, method of work, or any information regarding materials and equipment Contractor proposes to furnish shall not relieve Contractor of its responsibility for any errors therein and shall not be regarded as an assumption of risks or liability by the District, or its representatives, or any officer or employee thereof, and Contractor shall have no claim under the Contract on account of the failure or partial failure or inefficiency or insufficiency of any plan or method of work or material and equipment so accepted. Such acceptance shall be considered to mean merely that the District has no objection to Contractor using, upon its own full responsibility, the plan or method of work proposed, or furnishing the materials and equipment proposed.

GC-19 SUBSTITUTIONS AND EQUAL ALTERNATIVES

The work, unless otherwise permitted or approved by the District, shall be completed with the incorporated use of trade-named materials and equipment where such are specified. Substitutions and equal alternatives will be permitted as provided in this Section; however, neither the request for substitution nor the offer of alternatives shall in any way by their submittal obligate the District to assent to any request or offer. Failure of Contractor to submit proposed substitutions for review in accordance with this Section will be considered as evidence that the work shall be accomplished with trade-named materials and equipment as identified in the

Technical Specifications and shall be cause for rejection by the District of any other proposed substitutions.

Except when the specifications prohibit the substitution of a similar or equivalent material or article, Contractor may make written request to the District for approval of the use of alternative equipment or materials. Such request shall contain complete data intended to show that such alternative item is of a quality equal to or better than that specified and has the required characteristics for the intended use. Upon request, Contractor shall furnish to the District such additional information relating to such alternative items as the District may require.

Contractor shall submit written requests for substitutions to the District, within thirty-five (35) days of Contract award and prior to placing any purchase orders, but at least thirty (30) days before it requires approval of any such alternative item.

The burden of proof as to the quality and suitability of alternatives shall be upon Contractor, and it shall furnish all necessary information requested and required by the District. The District will be the sole judge as to the quality and suitability of alternative articles or materials, and its decision shall be final.

GC-20 QUALITY OF EQUIPMENT, MATERIALS, PRODUCTS, AND/OR WORKMANSHIP

The Contractor shall furnish all equipment, materials, and/or products required to complete the work, except equipment, materials, and/or products that are designated to be furnished by the District. Materials that are identified as District-furnished materials on the Project Drawings or in Part VI, Special Conditions, Section SC-15, District-Furnished Materials or Equipment, will be available to the Contractor free of charge, upon request, at the locations designated.

Only equipment, materials, and/or products meeting the requirements of the Contract shall be incorporated in the work. The equipment, materials, and/or products furnished and used shall be new and shall be manufactured, handled, and installed in a workmanlike manner to ensure a completed Project in accordance with the Contract. Manufacturers' warranties, guarantees, instruction sheets, and parts lists that are furnished with certain equipment, materials, and/or products incorporated in the work shall be delivered to the District before the Contract will be accepted.

If no detailed specifications are set forth, the Contractor shall furnish equipment, materials, and/or products in conformance with the latest standards, specifications, manuals or codes of an acceptable technical society, organization or association, or to the laws or regulations of any applicable governmental authority, whether such reference be specific or by implication, in effect at the time of opening of bids.

GC-21 INSPECTIONS AND SAMPLES

Unless otherwise provided in the Contract, all equipment, materials, and work shall be subject to inspection and testing by the District. The District shall have the right to reject equipment, materials, and work not in accordance with the Contract. Rejected work shall be satisfactorily corrected; rejected equipment shall be satisfactorily repaired or replaced with satisfactory equipment; and rejected material shall be satisfactorily replaced with satisfactory material, all in accordance with the Contract. The Contractor shall promptly segregate and remove rejected materials and equipment from the premises. All such correcting, repairing, replacing, and removing shall be by and at the expense of the Contractor.

The District will perform inspections in such manner as not to delay the work unreasonably, and the Contractor shall perform its work in such manner as not to delay inspection unreasonably. The Contractor shall give the District reasonable advance notice of operations requiring special inspections or tests, and it may request inspection of a portion of any work at any time by reasonable advance notice to the District. The Contractor shall, at its expense, furnish promptly all facilities, labor, and materials necessary and required for such inspection and tests.

Contractor shall provide work area access at all reasonable times to the District and its officers, agents, employees, and any other duly authorized representatives and employees, and all duly authorized representatives of governmental agencies having jurisdiction over work areas or any part thereof for the purpose of determining compliance with Contract requirements. The Contractor shall also arrange for the District, and its officers, agents, employees, and any other duly authorized representatives and employees, to have access at all reasonable times to all places where equipment or materials are being manufactured, produced, or fabricated for use under the Contract.

The Contractor shall furnish the District all reasonable facilities for the District's safety and convenience in inspecting work, at all times and at all places where inspection may take place. If the District finds that conditions are unsafe for inspection at a particular location, he may, upon notice to the Contractor, refuse to inspect in that location until such conditions are corrected. The Contractor shall bear any additional costs resulting from such action, including any costs incurred to permit subsequent inspection of any portion of work covered or completed at the location before correction of the conditions, whether or not such portion of work is found to meet Contract requirements.

The Contractor shall bear any additional inspection costs resulting from its failure to have a portion of work ready for inspection at the time requested by it for inspection, or from reinspection of any previously rejected portion of work where the defects requiring such rejection were due to the Contractor's fault or negligence. Such costs may be deducted, in whole or in part, from any monies due or that may become due to the Contractor under the Contract.

Inspection of materials and finished articles to be incorporated into any work may be made by the District at the place of production, manufacture, or shipment. When such inspection is to be performed, no such materials or finished articles shall be shipped from such place of inspection or incorporated in any work prior to inspection or without the written approval of the District. Equipment, materials, and work not in conformity with the Contract shall be corrected or replaced with satisfactory equipment and materials by and at the expense of the Contractor so as to conform to the Contract as determined by the District.

No acceptance of equipment, materials, or work shall be construed to result from such inspections by the District. Any inspections or tests or waivers thereof shall not relieve the Contractor of its responsibility for meeting the requirements of the Contract.

Where so required in the Contract, or whenever requested by the District, the Contractor shall, at its expense, promptly furnish to the District sample specimens of materials to be incorporated into any work. Samples shall be submitted in an orderly sequence so that dependent materials or equipment can be assembled and reviewed without causing delays in the work. Samples of material from natural sources shall be taken in the presence of the District; otherwise, the sample will not be considered for testing. Samples shall be tagged or labeled securely and fully

identified as to manufacturer, type, size or capacity, lot, and date, all as applicable and by reference to the applicable section and paragraph of the Contract. Materials for which samples are required shall not be used in any work until approved in writing by the District. Materials incorporated in any work shall conform to such samples as the District, in his discretion, determines meet the requirements of the Contract. Samples will be returned to the Contractor only at the discretion of the District.

GC-22 PROJECT DOCUMENTS AND RECORD DRAWINGS

The Contractor shall keep on the work site a copy of the Project Documents and shall at all times give the District access thereto. Any drawings included in the detailed Specifications shall be regarded as part thereto and of the Contract. Anything mentioned in these Specifications and not shown on the Project Drawings, or shown on the Project Drawings and not mentioned in these Specifications, shall be of like effect as though shown or mentioned in both. The District will furnish from time to time such detail drawings, plans, profiles, and information as he may consider necessary for the Contractor's guidance. It shall be the duty of the Contractor to see that the provisions of the Contract are complied with in detail irrespective of the inspection given the work during its progress by the District. Any failure on the part of the Contractor to observe the requirements contained in the Contract will be sufficient cause for the rejection of the work at any time before its acceptance.

The Contractor shall maintain, at the job site, one record set of Project Drawings in good order and clearly marked to show any deviations that have been made from the Project Drawings, including concealed construction and utility features that are revealed during the course of construction. Marked prints shall be updated at least once each week and shall be available to the District for review as to currency prior to developing partial payment estimates. Upon completion of the work, the marked set of prints shall be delivered to the District.

In the case of those drawings that depict the detail requirement for equipment to be assembled and wired in the factory, such as motor control centers and the like, the Record Drawings shall be updated by indicating those portions that are superseded by Change Order drawings or final shop drawings and by including appropriate reference information describing the Change Orders by number and the shop drawings by manufacturer, drawing, and revision numbers.

Requests for partial payments will not be approved if the updated set of drawings is not in good order or is not kept current. Request for final payment will not be approved until the complete and correct Record Drawings are delivered to the District.

GC-23 SAFETY REQUIREMENTS

In accordance with generally accepted construction practices and state law, Contractor shall be solely and completely responsible direction and control of the work and for conditions on the jobsite, including safety of all persons and property during performance of the work. This requirement shall apply continuously and not be limited to normal working hours.

Contractor shall take all necessary precautions and provide all necessary safeguards to prevent personal injury and property damage. Contractor shall provide protection for all persons including, but not limited to, its employees and employees of other contractors or subcontractors; and employees, agents, and representatives of the District and regulatory agencies that may be on or about the work. Contractor shall also take such measures as may

be necessary or required to assure that the safety and health of the employees and of the public may be safeguarded.

Contractor shall provide and maintain all necessary safety equipment such as fences, barriers, signs, lights, walkways, guards, and fire prevention and fire-fighting equipment and shall take such other action as is required to fulfill its obligations under this Section. It is the intent of the District to provide a safe working environment under normal conditions.

All work and materials shall be in strict accordance with all applicable state, city, county, and federal rules, regulations, and codes, and attention is drawn to the requirements of OSHA. Contractor shall be solely responsible for compliance with all city, county, and state explosive transport, storage, and blasting requirements and for any damages caused by its operations.

Contractor shall promptly and fully comply with and carry out safety, sanitary, and medical requirements as prescribed by federal, state, or local laws or regulations and industry standards. Contractor shall keep adequate first aid facilities and supplies available and instruction in first aid shall be given.

The services of the District in conducting review and inspection of Contractor's performance is not intended to include review of the adequacy of Contractor's work methods, equipment, bracing or scaffolding, or safety measures, in, on, or near the construction site. However, The District reserves the right to stop work if the District believes that there is an imminent danger to persons or property. Even though the District reserves such rights, the exercise of such rights is at the District's sole discretion, and such reservations will not be construed as an obligation of the District to monitor or enforce the Contractor's safety program. The District's exercise of these rights shall not provide a basis for delay damages, extra compensation, and/or additional compensation to complete the work.

All costs in connection with meeting the requirements of this Section shall be borne by Contractor.

GC-24 CLEANING UP

Contractor shall, at all times, keep the premises occupied by it and access to such premises in a neat, clean, and safe condition. During the progress of work, the Contractor shall, at a minimum:

1. Retain all stored items in an orderly arrangement allowing maximum access, not impeding drainage or traffic, and providing the required protection of material.
2. Provide adequate storage of all items awaiting removal from the job site, observing all requirements for fire protection and protection of the environment.
3. Remove any accumulation of scrap, debris, waste material, and other items not required for construction of this work.
4. Dispose of existing materials and equipment to be demolished and removed and all trash, such as broken concrete, wood blocking, shipping containers, etc., resulting from the contract work off the premises occupied by the Contractor, including District property, at the Contractor's expense. District-leased dumpsters and other disposal containers on District's property, unless specifically provided by the Contractor, shall not be used by the Contractor.

5. Maintain all work areas within Contract work limits free from dust, as determined by the District. Industry-accepted methods of dust control, suitable for the area involved, will be permitted. No separate payment will be made to Contractor for dust control.

Upon completion of any portion of any work, Contractor shall promptly remove all of its equipment, temporary structures, and surplus construction and other materials not to be used at or near the same location during later stages of work. Upon completion of any work and before final payment is made, Contractor shall, at its expense, satisfactorily dispose of all plant, buildings, rubbish, unused materials, concrete forms, and other equipment and materials belonging to it or used in the performance of work; and Contractor shall leave the premises in a neat, clean, and safe condition.

The Contractor shall, as a minimum, conduct daily inspections to verify that requirements of this Section are being met. If the Contractor fails to comply with any of the foregoing, the District will transmit written notification of noncompliance. If, within five (5) days of the written notification, the Contractor fails to comply, cleanup may be undertaken by the District at the expense of the Contractor.

GC-25 CONTAMINATED SOILS/MATERIALS

Contaminated soils and materials shall include, but not be limited to, pollutants and/or materials defined as hazardous substances or hazardous wastes under the Resource Conservation and Recovery Act (RCRA), the Comprehensive Environmental Response Compensation and Liability Act (CERCLA), the Hazardous Substances Control Act (Health and Safety Code Section 25300 and following), the Hazardous Waste Control Act (Health and Safety Code Section 25100 and following), or as defined as pollutants or contaminants under any other applicable state and federal laws and regulations. Said materials shall include, but not be limited to, friable asbestos, PCBs, petroleum products and its byproducts, and waste oil, among other substances.

Contractor shall notify the District by person or by telephone within two hours of discovery as to any contaminated soil or materials on or beneath the job site, including in buildings and related structures that could be impacted by the construction Project so discovered by the Contractor, its personnel, agents, representatives, consultants, or any other persons working under the direction and control of the Contractor. In addition, written notice shall be delivered to the District by the Contractor within 24 hours of discovery. Contractor shall require that like provisions be inserted in all contracts with its subcontractors and tiers of subcontractors. This shall not relieve the Contractor from the obligation and responsibility to ensure that the provisions of this General Condition are complied with.

The Contractor and its subcontractors shall immediately cease any and all work at the location of the discovery of the contaminated soils or materials until further notice from the District.

However, if the Contractor is specifically directed to conduct appropriate cleanup operations with respect to the contaminants discovered, the Contractor shall proceed with these operations. In addition, the Contractor shall notify the District of the discovery of said contaminants in the manner set forth above. Further, if the contaminants substantially vary from the description in the Contract as to type of material, quality of materials, level of concentration or toxicity, location, as to the materials' affect on groundwater, or vary in any other substantial manner from the description as set forth in the Contract, the Contractor shall immediately cease operations and notify the District in the manner set forth above.

All work done by the Contractor with respect to cleanup, removal, and remedial actions concerning the contaminated soils or materials shall be done according to law. All required notices shall be given by the Contractor to the County Environmental Health Hazard Materials Section and other appropriate governmental agencies, including the State Department of Toxic Substances Control and Regional Water Quality Control Board, among others. The Contractor or any subcontractor doing such work on behalf of the Contractor shall have the appropriate certification, licenses, and permits prior to commencing any such cleanup, removal, and/or remedial work. The District shall not be responsible for the negligence of or violation of any laws, rules, regulations, or ordinances by the Contractor or any of the Contractor's subcontractors, agents, consultants, employees, or representatives in doing such cleanup, removal, and remedial work.

If any of the cleanup, removal, containment, and remediation work substantially impacts upon the community, including, but not limited to, traffic, odor, and health issues, the District reserves the right to direct that the manner of operations by the Contractor be revised accordingly to reduce or eliminate the adverse effects.

GC-26 EXISTING UTILITIES AND INTERFERENCES

The locations of known existing utilities and pipelines are shown on the Project Drawings in their approximate locations. Some of the locations include multiple conduits. The Contractor shall exercise care in avoiding damage to those facilities that are to remain in service subsequent to the construction of the particular new facility involved, and it will be held responsible for their repair if damaged. The Contractor shall also exercise care in maintaining those pipes and facilities required for continuing operation of the existing facilities until such time as they can be abandoned. There is no guarantee that all utilities or obstructions are shown or that the locations indicated are accurate.

The Contractor shall be responsible for discovery of all existing underground installations in advance of excavating or trenching by contacting all local utilities 48 hours in advance and by prospecting. Contractor shall notify Underground Service Alert 48 hours prior to any excavation work.

The Contractor shall uncover and completely expose all piping where crossings, interferences, or connections are shown on the Project Drawings, prior to trenching or excavating for any pipe or structures, to determine actual elevations. New pipelines shall be laid to such grade as to clear all existing facilities that are to remain in service for any period subsequent to the construction of the run of pipe involved. If the Contractor does not expose all required utilities, it shall not be entitled to additional compensation for work necessary to avoid interferences or for repair to damaged utilities. Excavations around underground electrical ducts and conduits shall be performed using extreme caution to prevent injury to workers or damage to the electrical ducts or conduits.

Notwithstanding any other provision of this Contract between the District and the Contractor:

- A. In accordance with the provisions of Section 4215 of the California Government Code, in any contract to which the District is a party, the District shall assume the responsibility between the parties to the contract for the timely removal, relocation, or protection of existing main or trunk line utility facilities located on the site of any construction project and that are a subject of the Contract if such utilities are not identified by the District in

the Project Drawings and Specifications; provided, however, that nothing herein shall be deemed to require the District to indicate the presence of existing service laterals or appurtenances whenever the presence of such utilities on the site of the construction project can be inferred from the presence of other visible facilities, such as buildings, meter and junction boxes on or adjacent to the site of construction. The District will compensate the Contractor for the costs of locating and repairing damage and removing or relocating such utility facilities that are not indicated in the Project Drawings and Specifications, provided that the Contractor exercises due reasonable care.

- B. The owner of the utility shall have the sole discretion to perform repairs or relocation work or permit the Contractor to do such repairs or relocation work at a reasonable price.
- C. The Contractor shall not be assessed liquidated damages for delay in completion of the Project when such delay was caused by the failure of the District to show existing utilities or other existing facilities, excluding service laterals.

If interferences between existing utilities and proposed work occur at locations other than those shown on the Project Drawings, the Contractor shall notify the District, and a method for correcting said interference will be supplied by the District. Payment for correction of interferences not shown on the Project Drawings will be in accordance with the provisions of Section GC-27, Differing Site Conditions.

GC-27 DIFFERING SITE CONDITIONS

The Contractor shall promptly, and before the following conditions are disturbed, notify the District in writing of any:

1. Material that the Contractor believes may be material that is hazardous waste, as defined in Section 25117 of the Health and Safety Code, that is required to be removed to a Class I, Class II, or Class III disposal site in accordance with provisions of existing law.
2. Subsurface or latent physical conditions at the site differing materially from those indicated in the Project Documents and/or geotechnical report.
3. Unknown physical conditions at the site of any unusual nature, differing materially from those ordinarily encountered and generally recognized as inherent in work of the character provided for in the Contract.

Actions by the Contractor to disturb or cover the above conditions before the District is notified or has had the opportunity to investigate the conditions shall be deemed a waiver by the Contractor of any and all rights that the Contractor may have for additional compensation for increases in the Contractor's cost of, or the time required for, performance of any part of the work.

The District will promptly investigate the conditions; and if the District finds that the conditions do materially so differ, or do involve hazardous waste, and cause a decrease or increase in the Contractor's cost of, or the time required for, performance of any part of the work, the District will issue a Change Order in accordance with the provisions of Section GC-28, Changes.

In the event that a dispute arises between the District and Contractor whether the conditions

materially differ, or involve hazardous waste, or cause a decrease or increase in the Contractor's cost of, or time required for, performance of any part of the work, the Contractor shall not be excused from any scheduled completion date provided for by the Contract, but shall proceed with all work to be performed under the Contract. The Contractor shall retain any and all rights provided either by Contract or by law that pertain to the resolution of disputes and protests between the contracting parties.

GC-28 CHANGES

District may, at any time, by written change order make changes in the work, or extend the time to complete the work, as deemed necessary by District. The Contractor shall perform the work when so ordered. Any such change or request will be authorized in writing by the District, provided that in the event of an emergency, which the District determines endangers life or property, any work required by reason of such an emergency shall be performed in accordance with oral orders from the District, which will be confirmed in writing as soon as practicable. Any such authorization, whether written or oral, may be accompanied by drawings and data as are necessary to show the extent of such change or extra work.

If the District does not issue a written change order and the Contractor believes he is entitled to compensation or time in excess of the Contract amount arising out of the conduct of the work, Contractor may submit a written request for change to the District. Such requests for change will not be considered by the District unless the Contractor complies with the notification requirements of this paragraph. Contractor shall notify the District immediately upon learning of a condition, occurrence or circumstance that potentially will give rise to a request for change. If the initial notification is oral, Contractor shall confirm the notification in writing within five (5) days of the oral notification. The Contractor shall not proceed with the work involving the potential request for additional compensation without notifying the District of the subject conditions, occurrence, or circumstance unless an emergency exists or unless it is impossible to notify the District without creating an unreasonable delay in the work.

When changes in the work are required by the District or requested by Contractor, Contractor shall promptly estimate their effect on the cost or time of performance of this Contract and so notify the District. If requested by the District, Contractor shall supply any information to support Contractor's estimate of cost and/or time. No change shall be implemented by Contractor unless it is approved by the District in writing, and, unless otherwise agreed to in writing, the provisions of this Contract shall apply to all changes in the work.

If the District determines that any change materially affects the cost or time of performance of this Contract as a whole, Contractor and the District will mutually agree, in writing, to an equitable adjustment as specified in Section GC-29, Delays and Time Extensions and/or Section GC-30, Extra Work Payment. In the event of disagreement, the District will fix such adjustment that, in its opinion, be reasonable and proper, regard being had to all material and relevant factors including Contractor's direct costs and overhead. The Contractor may protest terms of such a change order in accordance with Section GC-31, Protest Procedure.

Contract change orders which affect the cost or term of performance shall be processed through the District's designated administrative representative, as shown in Section GC-5, Notices.

The District reserves the right to engage another contractor to perform the work if such engagement is in the District's best interest.

GC-29 DELAYS AND TIME EXTENSIONS

The time limits stated in the Contract are of the essence to the Contract. By executing the Contract, the Contractor confirms that the time limits set forth in the Contract, including interim or milestone dates, are reasonable periods for the performance of the work. The Contractor shall not be entitled to extensions of time limits at any time in the progress of the work unless the delay is occasioned by an act or neglect of the District or unless the delay in the completion of the work arises from unforeseeable causes beyond the control and without fault or negligence of both the Contractor and subcontractors or suppliers. Such unforeseeable causes may include: acts of God; acts of a public enemy; acts of a governmental entity not occasioned by the Contractor's, subcontractor's, or supplier's conduct; acts of another contractor in performance of a contract with the District; fires; floods; epidemics; quarantine restrictions; freight embargoes; unusually severe weather; or other delays of subcontractors or suppliers arising from unforeseeable causes beyond the control and without the fault or negligence of both the Contractor and such subcontractors or suppliers.

If the Contractor seeks an extension of time for the completion of any phase of the work, the Contractor shall submit a written request to the District for an extension of time for the portion of the work so delayed within five (5) days of the onset of such delay, and such request shall fully state the reasons for such delay. When such a request is received, the District will ascertain the reasons for and the extent of such delay. If the District determines that the facts justify an extension of time, the Contract will be modified accordingly, through a written change order. If the District determines that the facts do not justify an extension of time, such request will be denied. The District's finding of fact of either determination will be given to the Contractor, and such findings shall be final unless the Contractor files a protest under Section GC-31, Protest Procedure. No extension will be granted for any portion of any delay unless the required written request is made by the Contractor as specified herein and the District finds justification for the request.

In any event, the Contractor expressly waived any right to delay damages from the District where a reasonable extension is granted, except when the District is responsible for the delay of the Contractor's performance of the work and which delay is unreasonable under the circumstances involved and not within the contemplation of the parties.

No time extensions will be granted nor extended overhead paid until a delay occurs which:

1. Impacts the Project's critical path,
2. Consumes all available float, slack time, or schedule contingency within the construction schedule (the time between the Contractor's scheduled early completion date and the Contract completion date), and
3. Extends work beyond the Contract completion date.

Float, slack time, or schedule contingency within the construction schedule is not for the exclusive use or benefit of the District or the Contractor but is a resource available to both parties as needed.

Except as limited by Section 7102 of the Public Contract Code, should the Contractor sustain any loss, damage, or delay through any act or omission of any other contractor or entities, the Contractor expressly waives any rights and any claims against the District, other than for an extension of time.

GC-30 EXTRA WORK PAYMENT

If the District determines that any change in the work materially affects the cost of this Contract as a whole, there shall be an equitable adjustment in the payment price. The price adjustment shall be determined by one of the following methods in the order of preference listed:

- A. Unit Price Change: Based on the unit prices contained in Section 2, Schedule of Bid, Part III, Bid Forms.

If there is a variation in the estimated Bid quantity listed in Section 2, Schedule of Bid, Part III, Bid Forms by more than one hundred fifty percent (150%) or less than fifty percent (50%) of the Bid quantity, either the District or the Contractor may notify the other party of their desire to renegotiate the Contract unit price with respect to those quantities outside of the permitted range of fifty percent (50%) below to one hundred fifty percent (150%) above the Bid quantity.

- B. Agreed Price Change: Mutually agreed-upon lump sum or unit price adjustment.

- C. Cost Plus Change: Contractor's actual cost of labor (wages and benefits), materials (actual purchase price, sales tax, freight and delivery) and equipment/tools (at actual or fair/prevaling rental rates) directly engaged in the performance of the extra work plus a fifteen percent (15%) mark-up for overhead and profit. A five percent (5%) mark-up will be added to the cost of extra work performed by subcontractors.

For cost plus changes, Contractor shall provide to District an itemized breakdown of the quantities and prices used in the extra work, and it shall make available all source documents for itself and any subcontractors, including but not limited to payroll records, invoices, purchase orders, contracts and lease agreements. Contractor shall keep accurate records that clearly delineate the extra work from other Contract work.

The total payment made as provided above shall be deemed to be the actual cost of such work, including overhead costs, and shall constitute full compensation therefore.

When extra work is performed by subcontractor forces, Contractor shall reach agreement with such other forces as to the distribution of the payment made by the District for such work. No additional payment will be made by the District by reason of the performance of the work by a subcontractor.

GC-31 PROTEST PROCEDURE

If the Contractor objects to any direction, instruction, determination or decision provided by the District, the Contractor may submit a written protest. All such written protests must be submitted within ten (10) days after such direction, instruction, determination or decision is delivered to the Contractor in writing. If the direction, instruction, determination or decision is oral, Contractor must request that the District provide said oral direction, instruction,

determination or decision within five (5) days of receiving the oral direction, instruction, determination or decision. The Contractor shall proceed without delay to perform work as directed, instructed, determined, or decided by the District and shall comply promptly with such directions, instructions, determinations, or decisions.

Written protests shall clearly state in detail the Contractor's objections, the reasons therefor, and the nature and amount of additional compensation or extension of time, if any, to which the Contractor contends it will be entitled thereby. It shall also include, if possible, Contract specification references, quantities, costs and any related detailed records.

The District will issue a decision upon each protest. If the District determines that the facts support the protest, the Contract will be modified accordingly, in writing. If the District determines that the facts do not support the protest, such request will be denied. The District's finding of fact of either determination will be given to the Contractor and such findings shall be final and conclusive.

If the Contractor disagrees with any terms or conditions set forth in an approved contract change order which it has not executed, and does not submit a written protest within the time specified above, payment will be made as set forth in the approved contract change order, and such payment shall constitute full compensation for all work included therein or required thereby.

The Contractor shall be deemed to have waived all grounds for protest of direction, instruction, determination, or decision and all claims for additional compensation, extensions of time, or damages occasioned thereby for which protest could have been made under this Section, and shall further be deemed to have accepted such direction, instruction, determination, or decision as being fair, reasonable, and determinative of the Contractor's obligations and rights under the Contract.

GC-32 RECORDS AND ACCOUNTS

The Contractor shall, at its expense, keep and maintain such records and accounts and shall require its subcontractors and suppliers to keep records and accounts in connection with the performance of the Contract. The Contractor shall maintain, in a businesslike manner, records, accounts, and other evidence directly pertinent to the performance of work under this Contract in accordance with Generally Accepted Accounting Principles and practices consistently applied and applicable under California and federal law. The Contractor shall also maintain the financial information and data used by the Contractor in the preparation or support of cost submissions required for this Contract or any Change Order. The District, or its authorized representatives, shall have access, at all times during normal business hours, to such records, accounts, and other evidence for the purpose of inspection, audit, and copying. The Contractor shall provide proper business facilities for such access, inspection, and copying at no cost to the District.

The Contractor shall furnish to the District, upon request, an accurate written allocation of the total amount of the price paid for performance of work under the Contract to the various elements of the work, as may be required by the District for accounting purposes and for public record. If the District determines that any price (including profit) negotiated in connection with this Contract, Change Order, or any cost reimbursable under this Contract, was increased by any significant sum because the Contractor, subcontractor, or supplier furnished incomplete or inaccurate cost or pricing data or data not current, then such price or cost or profit shall be

reduced accordingly and the Contract shall be modified in writing to reflect such reduction. Failure to agree on a reduction under this Section shall be subject to Section GC-31, Protest Procedure.

Such records and accounts shall remain accessible to the District for a period of not less than three (3) years beyond the date of formal acceptance as provided under Section GC-35, Acceptance of the Contract and Final Payment. The Contractor shall agree to include this Section in all its contracts, subcontracts, and purchase orders with suppliers in excess of \$10,000.

GC-33 PROGRESS PAYMENTS

- A. Monthly Progress Payments: Monthly progress payments will be made as the work proceeds. Such payments will be made according to estimates of the amount and value of work satisfactorily performed by the Contractor up to the time of each estimate.

Progress payment estimates shall be made by the Contractor and submitted to the District for review and concurrence. Once the District has agreed to the items of cost, the Contractor shall prepare a progress payment request and submit the request for payment. The burden of requesting payment is on the Contractor. The District has no obligation to pay for a separate item of cost unless that item of cost is included in a progress payment request by the Contractor.

Contractor's progress payment requests shall be made in writing on or about the twenty-fifth (25th) day of each calendar month, and payment will be made within twenty-one (21) days after the District verifies that the request has been properly filed and submitted. Progress estimates will not be required to be made by strict measurement, but may be by measurement or by estimation or partly by one method and partly by another.

Pursuant to Section 20104.50 of the Public Contract Code, the District will pay interest on progress payments held over thirty (30) days from the date of submission, as long as the request for payment by the Contractor is deemed properly filed and submitted. A request for payment by the Contractor will not be deemed properly filed or submitted until such time as the Record Drawings are reviewed and found to be current. The date of submission is the date the District's representative signs the progress payment request form in the space provided for the District. This signature will verify that the request has been properly filed and submitted.

- B. Detailed Cost Breakdown: Prior to preparation of the first progress payment request by the Contractor, the Contractor shall submit to the District a detailed cost breakdown of the work under each bid item awarded. If the initial detailed cost breakdown is not accepted by the District, additional cost breakdowns shall be submitted by the Contractor until the District determines that the cost breakdown is acceptable. Upon acceptance by the District, the breakdown will then become the basis for partial payment determination. Bond and insurance costs shall not be considered a separate item of cost for this purpose but shall be included in mobilization/demobilization.
- C. Retainage: In making progress payments, the District shall retain five percent (5%) of the cumulative estimated amount until final acceptance of all work under the Contract as set forth under Section GC-35, Acceptance of Contract and Final Payment. The

Contractor shall be allowed to substitute securities for any monies withheld to ensure performance under this Contract, or the Contractor may request that the District have such funds, which the District would otherwise withhold from progress payments to ensure performance, deposited in an escrow account pursuant to Section 22300 of the California Public Contract Code. The Contractor may exercise the option of substituting securities or depositing funds in an escrow account by executing the Escrow Agreement for Security Deposits in Lieu of Retention in the form supplied by the District upon request.

- D. Withholding Payment: Any payments otherwise payable under the Contract may be withheld, in whole or in part, by the District, if in the discretion of the District, it is necessary to protect the District from loss due to the following:
1. Defective work that is not remedied; or
 2. Third-party claims filed or reasonable evidence indicating probable filing of such claims; or
 3. Contractor's failure to make payments to subcontractors for labor, equipment, materials, or products to which a subcontractor is entitled; or
 4. Evidence that the work cannot be completed for the unpaid balance of the Contract sum; or
 5. Contractor's failure to submit an acceptable construction schedule or failure to update the schedule; or
 6. Any and all damage to the District, or another contractor, resulting from the Contractor's action or inaction; or
 7. Contractor's failure or inability to maintain insurance coverage and bonds as required by the Project Documents throughout the course of the job; or
 8. Contractor's repeated failure to carry out the work in accordance with the Project Documents; or
 9. Contractor's failure to provide copies of certified payrolls, as specified in this Section GC-7, Laws, Regulations and Prevailing Wages; or
 10. Contractor's failure to comply with the laws or regulations of any federal, state, or local government; or
 11. Untimely repair of any damage resulting from the Contractor's operations or untimely restoration of property, affected by the construction, to a preconstruction condition.

In addition, the District may deduct from any progress payment due the Contractor any amount the District may be currently, or in the future, authorized to retain pursuant to federal, state, or local laws or regulations, any amount due the District from the Contractor, and any other amount that the District is otherwise authorized to retain as specified in Part VI, Special Conditions.

The District will withhold an amount from any progress payment due the Contractor, which will not exceed twice the value of any necessary repairs, corrections, or replacements, to assure that the Contractor completes all repairs, corrections, or replacements for which the Contractor is responsible. The Contractor shall receive

payments of said retained amount after the repairs, corrections, or replacements are completed.

Any amount withheld for the reasons stated above shall be based on estimates made by the District and shall be in addition to any amount previously withheld. The Contractor may avoid withholding of amounts from a progress payment by eliminating the cause of the withholding to the satisfaction of the District.

If the Contractor fails to meet the obligations set forth above, upon written notice by the District, the District may discharge such obligations and deduct all costs in connection with the District's discharge of Contractor's obligations from any payments that may become due to the Contractor. If the amount withheld from payment(s) is insufficient to meet such costs, or if any claim or charge against the Contractor shall be discharged by the District after the final Contract payment is made, Contractor and its Sureties shall promptly pay the District all costs incurred thereby, regardless of when such claim arose or whether such claim constitutes a lien upon the Project or the real property upon which the Project is situated.

In the event that District finds Contractor in default, such that the District calls upon the Contractor's surety to perform the remainder of the project, including but not limited to entering into a takeover agreement with Contractor's surety, Contractor shall execute all documents as necessary to transfer or assign the Escrow Agreement called for herein. Contractor shall notify the District of such assignment and transfer such that District shall be fully informed.

- E. Ownership and Waiver: All equipment, materials, products, and work covered by progress payments will, upon payment, become the property of the District. However, this provision shall neither be construed as constituting acceptance of any work or as relieving the Contractor from the sole responsibility for all equipment, materials, products, and work upon which payments have been made, including the restoration of any damaged work until final acceptance thereof, unless specifically provided for elsewhere. The payment for any equipment, material, products, and work covered by a progress payment does not constitute a waiver of the District's right to require fulfillment of all of the terms of the Contract.

The Contractor's acceptance of any payment made under the terms of this Contract shall operate as, and shall be, a release to the District and a waiver of all claims by the Contractor against the District that may arise from the completed work for which payment has been made, except those claims previously submitted to the District in writing pursuant to Government Code Section 901 et seq., which are disputed at the time of the payment.

- F. Subcontractor Payments: The District informs Contractor, and Contractor by execution of the Contract takes cognizance of the following: Contractor must pay progress payments to subcontractors no later than seven (7) days after receipt from the District. If Contractor fails to make progress payments to subcontractors within seven (7) days, then Contractor is subject to penalties of 2% per month, disciplinary action, and attorneys' fees of subcontractors.
- G. Payment for Equipment, Materials, and Products: Generally, the Contractor will not be compensated for equipment, materials, and/or products delivered to the site until after

they are incorporated in the work. However, if the District determines that the progress of the work will benefit by the delivery to the site of certain equipment, materials, and/or products in advance of their actual requirement, and if such equipment, materials, and/or products are delivered, a portion of the cost of the equipment, materials, and/or products may be included in progress payments.

GC-34 LIENS AND STOP NOTICE

If at any time any notices of lien are filed for labor performed or materials or equipment manufactured, furnished, or delivered to or for the work, the Contractor shall, at its own cost and expense, promptly discharge, remove, or otherwise dispose of the same; and until such discharge, removal, or disposition, the District shall have the right to retain from any monies payable to the Contractor an amount that, in the District's sole judgment, the District deems necessary to satisfy such liens and pay the costs and expenses, including attorneys' fees, of defending any actions brought to enforce the same, or incurred in connection therewith or by reason thereof.

If, at any time prior to the expiration of the period for service of a Stop Notice, there is served upon the District a Stop Notice as provided in Sections 9350 through 9510 of the Civil Code of the State of California, the District shall, until the discharge thereof, withhold from the monies under its control so much of said monies due or to become due the Contractor under this Contract as shall be sufficient to answer the claim stated in such Stop Notice and to provide for the reasonable cost of any litigation thereunder, provided that, in the District's discretion, permit the Contractor to file with the District the bond referred to in Section 9364 of the Civil Code of the State of California, said monies shall not thereafter be withheld on account of such Stop Notice. The monies that the District withholds shall be a minimum of one hundred twenty-five percent (125%) of the face value of the Stop Notice.

GC-35 ACCEPTANCE OF CONTRACT AND FINAL PAYMENT

- A. Final Acceptance: Whenever the Contractor deems that its obligations under the Contract have been fulfilled, the Contractor shall, in writing, so notify the District. This notification shall include a request for the District to make a final inspection. Upon receipt of such notice, the District will, in company with the Contractor, inspect the work that has been performed. If the District determines that the request is appropriate, the District will make a final inspection.

If any deficiencies are discovered by the District during the final inspection of the work, a "punch list" stating the deficiencies will be prepared and transmitted to the Contractor for correction. Upon correction of the deficiencies, the Contractor shall notify the District. The District will reinspect the corrected work. If the District determines that all work is completed except for minor punch-list items, and that all other requirements of the Contract have been met, the District will recommend acceptance of the Contract work to the District's General Manager.

Immediately upon acceptance by the General Manager and without further acknowledgement by the parties, the Contractor is relieved of the duty of maintaining and protecting the Contract work as a whole except as required by the warranty, guaranty, insurance, indemnity, and all other conditions of the Contract that are intended to continue after acceptance of the Contract. Guaranty and warranty periods required by

the Contract and the statutory period for the filing of liens and Stop Notices shall commence on the date of acceptance by the General Manager.

Additionally, upon the General Manager's acceptance of the Contract work, the District will cause a Notice of Completion of all work under the Contract to be filed in the office of the District and the office of the County Recorder of Tuolumne County, in accordance with Section 4005 of the Government Code of the State of California. Upon expiration of the statutory period for filing of liens and Stop Notices and provided no liens or Stop Notices have been filed, the District will authorize release or release the retention, less all such amounts the District may be authorized or required to reserve or retain.

- B. Release of Claims and Subcontractor Payments: The Contractor shall provide a release of all claims arising out of work related to undisputed Contract amounts. Final payment shall be subject to the Contractor's execution of a release in favor of the District, its directors, officers, representatives, agents, and employees, as to all claims arising out of the Contract work and District liability to the Contractor, or any third party, for anything done in relation to or furnished for any work related to undisputed Contract amounts. Such release shall include claims for any act or omission of the District, its directors, officers, representatives, agents, and employees, respectively, or of any person relating to or affecting any work related to such final payment. All prior progress payments, being estimates, will be subject to adjustment in the final payment.

Claims by the Contractor for additional compensation or damages remaining in dispute, as set forth in the final payment release, shall be excluded from the terms of the release. The District may withhold from the final payment up to one hundred fifty percent (150%) of the estimated value of claims by the District, or third parties against the Contractor, including but not limited to, claims regarding amounts previously paid to the Contractor by the District.

The release signed by the Contractor as part of the final payment shall be in substantially the following form:

Final Payment and Release

District Project Name _____
District Project Number _____

The acceptance by Contractor of the final Contract payment in the sum of \$ _____ covering undisputed Contract amounts shall operate as, and shall be a release to the Twain Harte Community Services District (District), the District's directors, officers, representatives, agents, and employees, respectively, from all claims of and liability to the Contractor (except as set forth below), including claims of the Contractor as the successor in interest by assignment or otherwise, to claims of laborers, mechanics, subcontractors, consultants, and materialmen, and including claims by laborers, mechanics, subcontractors, consultants, and materialmen as successors in interest by assignment or otherwise, arising out of the work performed under the Contract which are related to said undisputed Contract amounts. This Release shall be effective as to all claims of the Contractor arising out of or in connection with the performance of the work under this Contract with respect to said undisputed Contract amounts, including tort claims, which are known to the Contractor or reasonably should have been known to the Contractor at the date of the signing of this Release. The

acceptance by Contractor of the final Contract payment described above shall operate as a waiver of all claims described herein and of any entitlement to additional payment arising out of the Contract, except as to those claims by the Contractor and their respective estimated dollar amounts listed herein below. It is understood that the amounts set forth below are good faith estimates and may be subject to some reasonable modification. It is intended that this Release be construed in accordance with the limitations set forth in California Public Contract Code, Section §7100.

<u>DESCRIPTION OF DISPUTED CLAIM</u>	<u>ESTIMATED AMOUNT OF DISPUTED CLAIM</u>
_____	\$ _____

Signed: _____

By: _____
(typed or printed)

Title: _____

Company Name: _____

Date: _____

The District, at its discretion, may elect to issue final payments directly to certain of the subcontractors, or to issue joint check payments, payable to the Contractor and subcontractor involved. Contractor agrees to verify the correctness of any final payments to be made to subcontractors by the District and acknowledge the same in writing to the District within five (5) days of written request from the District. If the Contractor disputes the correctness of any final payment to be made to a subcontractor, the Contractor shall so notify the District in writing of the matters in dispute and the amounts thereof. The notice shall be in writing delivered to the District within five (5) days of the above-written request from the District. Said payments shall be made in accordance with estimates made by the Contractor and/or subcontractor and approved by the District of the amount and value of work satisfactorily performed by the subcontractor. Amounts so paid to the subcontractor shall be deducted from any amounts due to the Contractor under the terms of the Contract and any Change or Extra Work Orders. However, to the extent that the Contractor disputes any portion or all of the estimated payment due a subcontractor, an amount not to exceed one hundred fifty percent (150%) of the disputed amount will be withheld from the payment to the subcontractor. If the entire amount due to the subcontractor is disputed by the Contractor, then up to one hundred fifty percent (150%) of this entire amount may be deducted from payments to the Contractor until the dispute is resolved.

If, as stated above, the District elects to issue final payments to a subcontractor or subcontractors or to issue joint check payments, the District may request, as part of its payment to the subcontractor or subcontractors involved, that said subcontractor or

subcontractors sign a Conditional Waiver and Release Upon Final Payment to the subcontractor, which shall be in substantially the following form:

Conditional Waiver and Release Upon Final Payment to Subcontractor

Upon receipt by the undersigned of a check from Twain Harte Community Services District (District) in the sum of \$_____ payable to _____ and when the check has been properly endorsed and has been paid by the bank upon which it is drawn, this document shall become effective to release any mechanic's lien, Stop Notice, or bond right the undersigned has on the Contract. This release covers the final payment of the undersigned for all labor, services, equipment, or material furnished on the job, except for disputed claims for additional work described in the attached sheet, if any, in the amount of \$_____.

Before any recipient of this document relies on it, said party should verify evidence of payment to the undersigned.

Date: _____
By: _____
Title: _____
_____ Company Name

GC-36 SURVIVAL

Notwithstanding the District's acceptance of the work and payment, Contractor shall remain obligated under all clauses of this Contract, which expressly or by their nature extend beyond and survive such acceptance and payment or termination.

GC-37 WARRANTY

Contractor warrants that the work performed pursuant to the Contract shall be of the quality specified or of the highest quality if no quality is specified, and shall conform to the specifications, drawings, samples, and other descriptions set forth in the Contract. Contractor warrants all equipment and materials furnished by it and all work performed by it under the Contract against defective design (unless furnished by the District), materials, and workmanship for a period of one (1) year from and after final acceptance regardless of whether the same were furnished or performed by Contractor or by any of its subcontractors or suppliers of any tier. Performance and Payment Bonds, if any, shall remain in full force and effect during such warranty periods.

If, after installation and acceptance, the operation or use of the material or equipment furnished under this Contract proves to be unsatisfactory to the District, the District shall have the right to operate and use such materials and equipment until it can, without damage to the District, be taken out of service for correction or replacement by Contractor at its expense. The warranty period for the materials or equipment which are replaced shall be one (1) year from and after the replacement materials or equipment are satisfactorily installed.

Upon receipt of written notice from the District of any breach of warranty during the applicable warranty period, the affected item shall be redesigned, repaired, or replaced by Contractor and

it shall perform such tests as the District may require to verify that such redesign, repairs, and replacement comply with the requirements of the Contract. As to the redesigned, repaired, or replaced work, Contractor warrants such redesigned, repaired, or replaced work against defective design, materials, and workmanship for a period of one (1) year from and after the date of acceptance of such work. The District reserves the right to require that Contractor perform such repair or replacement work.

The District also reserves the right to make such repairs or replacements, if, within seven (7) calendar days after mailing of a notice in writing to Contractor and Surety, if any, Contractor shall neglect to make or undertake with due diligence the aforesaid repairs or replacements and that Surety, if any, within seven (7) calendar days after mailing of a notice in writing of such negligence of Contractor shall neglect to make or undertake with due diligence the aforesaid repairs or replacements itself, provided, however, that in the case of an emergency where in the opinion of the District delay would cause hazard to health or serious loss or damage, repair may be made without notice being sent to Contractor or Surety, and Contractor shall pay the cost thereof.

All costs, including manpower and materials incidental to such redesign, repair, replacement, and testing, including the removal, replacement, and reinstallation of equipment necessary to gain access and all other costs incurred as the result of a breach of warranty shall be borne by Contractor whether performed by the District or Contractor.

Nothing in this section shall be construed to limit, relieve or release Contractor's, subcontractor's, and equipment supplier's liability to the District for damages sustained as the result of latent defects in the equipment furnished caused by the negligence of the supplier's agents, employees or subcontractors.

The Performance Bond shall extend for a period of one (1) year after acceptance of the Contract by the District and shall cover the Contractor's obligations resulting from the warranty requirements herein specified.

GC-38 COST-REDUCTION INCENTIVE

The Contractor may submit to the District, in writing, proposals for modifying the Project Drawings, Technical Specifications, or other requirements of the Contract for the sole purpose of reducing the total cost of construction. The cost-reduction proposal shall not impair in any manner the essential functions or characteristics of the Project, including but not limited to service life, economy of operation, ease of maintenance, desired appearance, or design and safety standards.

Cost-reduction proposals shall contain the following information:

1. A description of both the existing Contract requirements for performing the work and the proposed changes.
2. An itemization of the Contract requirements that must be changed if the proposal is adopted.
3. A detailed estimate of the cost of performing the work under the existing Contract and under the proposed change. The estimates of cost shall be priced in the same manner as if the work were to be paid for as an extra work payment, as provided in Section GC-30, Extra Work Payment.

4. A statement of the time within which the District must make a decision thereon.
5. The Contract items of work affected by the proposed changes, including any quantity variation attributable thereto.

The provisions of this Section shall not be construed to require the District to consider any cost-reduction proposal that may be submitted hereunder. The District will not be liable to the Contractor for failure to accept or act upon any cost-reduction proposal submitted pursuant to this Section nor for any delays to the work attributable to any such proposal. If a cost-reduction proposal is similar to a change in the Project Drawings or Technical Specifications under consideration by the District for the Project at the time said proposal is submitted, or if such a proposal is based upon or similar to standard specifications, standard special provisions, or standard plans adopted by the District after the advertisement for the Contract, the District will not accept such proposal, and the District reserves the right to make such changes without compensation to the Contractor under the provisions of this Section.

The Contractor shall continue to perform the work in accordance with the requirements of the Contract until an executed Change Order incorporating the cost-reduction proposal has been issued. If an executed Change Order has not been issued by the date upon which the Contractor's cost-reduction proposal specifies that a decision thereon should be made, or such other date as the Contractor may subsequently have specified in writing, such cost-reduction proposal shall be deemed rejected.

The District shall be the sole judge of the acceptability of a cost-reduction proposal and of the estimated net savings in construction costs from the adoption of all or any part of such proposal. In determining the estimated net savings, the right is reserved to disregard the Contract bid prices if, in the judgment of the District, such prices do not represent a fair measure of the value of work to be performed or to be deleted.

If the Contractor's cost-reduction proposal is accepted in whole or in part, such acceptance will be a Contract Change Order, which shall specifically state that it is executed pursuant to Section GC-28, Changes. Such Change Order shall incorporate the changes in the Project Drawings and Technical Specifications that are necessary to be put into effect and shall include any conditions upon which the District's approval thereof is based if the approval of the District is conditional. The Change Order shall also set forth the estimated net savings in construction costs attributable to the cost-reduction proposal effectuated by the Change Order and shall further provide that fifty percent (50%) of said estimated net savings amount be included as compensation for the Contractor. The Contractor's cost of preparing the cost-reduction proposal shall be excluded from consideration in determining the estimated net savings in construction costs.

The District reserves the right, where it deems such action appropriate, to require the Contractor to share in the District's costs of investigating a cost-reduction proposal submitted by the Contractor as a condition of considering such proposal. Where such a condition is imposed, the Contractor shall indicate its acceptance thereof in writing, and such acceptance shall constitute full authority for the District to deduct amounts payable to the District from any monies due or that may become due to the Contractor under the Change Order. The Change Order incorporating the cost-reduction proposal and the Contractor's fifty percent (50%) share of the net savings will also include any deductions for the Contractor's share of the District's cost of investigating the proposals per the agreement between the District and the Contractor.

Acceptance of the cost-reduction proposal and performance of the work thereunder shall not extend the time of completion of the Contract, unless specifically provided for in the Contract Change Order authorizing the use of the cost-reduction proposal.

The amount specified to be paid to the Contractor in the Change Order that effectuates a cost-reduction proposal shall constitute full compensation to the Contractor for the cost-reduction proposal and the performance of the work thereof pursuant to the said Change Order.

PART VI SPECIAL CONDITIONS

INDEX

Section	Title
SC-1	Insurance
SC-2	Beginning and Prosecution of the Work
SC-3	Hours of Work
SC-4	Basis of Payment
SC-5	Liquidated Damages
SC-6	Substantial Completion and Project Milestones
SC-7	Shutdowns and Connections
SC-8	Use of Completed Portions of Work
SC-9	Special Safety Precautions
SC-10	Contractor Facilities
SC-11	Security
SC-12	Storage of Materials and Equipment
SC-13	Salvage and Disposal of Materials
SC-14	Use of District-Owned Equipment
SC-15	District-Furnished Materials or Equipment
SC-16	Access and Cooperation
SC-17	Protection and Restoration of Property
SC-18	Storm Water Pollution Prevention
SC-19	Cultural Resources
SC-20	Environmental Requirements

**PART VI
SPECIAL CONDITIONS**

SC-1 INSURANCE

A. Contractor shall, at its expense, procure and maintain insurance provided by insurance companies with an A.M. Best's Insurance Rating of "A:VII" or better on all of its operations under this Contract for the duration of the Project and the warranty period, except for the liability insurance for the Products-Completed Operations Hazard as specified in Subsection A.2, as follows:

1. Workers' Compensation and Employer's Liability Insurance: Workers' Compensation Insurance shall be provided as required by any applicable law or regulation. Employer's Liability Insurance shall be provided in amounts not less than \$1,000,000 per accident, \$1,000,000 per each employee for disease, and \$1,000,000 policy limit.

The insurer shall waive all rights of subrogation against the District, its officers, directors, and employees.

2. General Liability Insurance: Contractor shall carry general liability insurance covering all operations by or on behalf of Contractor for the following limits of liability:
 - a. Minimum combined single limit of liability of \$2,000,000 or the limits required by law, whichever is greater for each occurrence for bodily injury and property damage;
 - b. Minimum limit of liability of \$2,000,000 each person for personal and advertising injury liability;
 - c. Minimum limit of liability of \$2,000,000 each occurrence for products/completed operations liability;
 - d. General aggregate limit of not less than \$2,000,000, which shall be provided on a per project basis.

Contractor's General Liability Insurance shall be written on an "occurrence" form and provide coverage at least as broad as the most recent version of Insurance Services Office Commercial General Liability form CG 0001.

Coverage shall include, or be endorsed to include:

- a. Coverage for personal injury liability assumed under contract;
- b. Liability arising out of the use and operation of any District-furnished equipment by the Contractor, its personnel and others;
- c. XCU coverage for claims arising from explosion, collapse and underground damage;
- d. Accidental spillage, cleanup and other related costs;

- e. Contractual liability coverage for all oral and written contracts including indemnity provisions contained herein;
- f. Cross Liability and Severability of Inter

The District, its officers, directors, and employees shall be named as additional insureds on the Contractor's policies by a provision or endorsement providing coverage at least as broad as Insurance Services Office's Additional Insured - Owners, Lessees, or Contractors (Form B) endorsement Number CG 2010 11/85.

The required additional insured coverage for the District shall be primary and specify that any other insurance or self-insurance maintained by the District shall not be called upon to contribute with Contractor's insurance.

Contractor shall maintain liability insurance for the "Products-Completed Operations Hazard" for three (3) years following completion of Contractor's work under this Contract and acceptance by the District. Contractor shall provide updated Certificates of Insurance to the District during these subsequent three (3) years as evidence of continued coverage.

- 3. Automobile Liability Insurance: The Contractor shall carry Automobile Liability Insurance at least as broad as the most recent version of Insurance Services Office Business Automobile Liability (form Number CA 0001) on all owned, non-owned, and hired autos, with a single limit for bodily injury and property damage of \$2,000,000 per occurrence. The coverage shall remain in force during the warranty period. The policy shall also include liability arising out of the use and operation of District-furnished vehicles by the Contractor, its personnel, and others.

B. The following provisions shall also apply:

- 1. Each required insurance policy shall be endorsed to state that coverage shall not be canceled or reduced without thirty (30) days' prior written notice to the DISTRICT. Ten (10) days' notice shall be provided for cancellation for nonpayment of premiums.
- 2. Deductibles shall not exceed \$5,000 per occurrence with a deductible aggregate of \$5,000. The Contractor shall be solely responsible for payment of deductibles.
- 3. CONTRACTOR shall furnish the DISTRICT with original, signed certificates and original, signed amendatory endorsements. All such certificates and endorsements shall be received and reviewed by the DISTRICT before any work begins under this agreement. The certificates and amendatory endorsements shall be signed by an individual who is authorized to sign on behalf of the insurer covering the CONTRACTOR.
- 4. The DISTRICT reserves the right to require complete, certified copies of all required insurance policies at any time.
- 5. CONTRACTOR shall include all SUBCONTRACTORS as insureds under its policies or shall cause each SUBCONTRACTOR employed by CONTRACTOR to purchase

and maintain insurance of the types and limits specified in this section. Upon the DISTRICT's request, CONTRACTOR shall furnish copies of certificates and endorsements evidencing coverage for each SUBCONTRACTOR.

6. All insurance correspondence, notices, certificates, and endorsements shall each separately reference "All DISTRICT Operations" or "All DISTRICT Projects."
7. In the event CONTRACTOR fails to comply with this Section, the DISTRICT may take such action as the DISTRICT deems necessary to protect the DISTRICT's interest. Such action may include but is not limited to termination of the Contract, withholding of payments, or other actions as the DISTRICT deems appropriate.

SC-2 BEGINNING AND PROSECUTION OF THE WORK

Contractor shall be authorized to begin work upon receipt of the Notice to Proceed, and shall begin work within ten (10) calendar days from said receipt. Submittal preparation shall count as commencing work. Contractor shall diligently prosecute the work to completion with the time of performance provided below:

<u>MILESTONE</u>	<u>COMPLETION DATE</u>
Online Operation	October 1, 2023
Substantial Completion	December 1, 2023

Contractor shall notify the District in writing of its intent to begin work at the site at least 10 (ten) working days before work is actually begun. Contractor shall also promptly notify the District of any Contractor-initiated suspensions and resumptions of work during the contract period, allowing as much advance warning as possible. The notice to resume work shall be given to the District not less than one working day in advance of resuming work.

Contractor shall prosecute the work with sufficient forces, construction plant, and equipment and shall work such hours, including extra shifts and overtime operations as may be necessary to ensure the completion of the work in accordance with the construction schedule and specified time of performance.

If at any time during the progress of work, the Contractor's actual progress, as determined by the District, is inadequate to meet the requirements of the Contract, the District may notify the Contractor of such imminent or actual noncompliance with the Contract. The Contractor shall thereupon take such steps as may be necessary to improve its progress including, but not limited to, an increase in the labor force, the number of shifts, and/or overtime operations, days of work and/or the amount of construction equipment, all without additional cost to the District. Neither such notice by the District nor the District's failure to issue such notice shall relieve the Contractor from its obligations to achieve the quality of work and rate or progress required by the Contract.

Failure of the Contractor to comply with the instructions of the District under these provisions may be grounds for determination by the District that the Contractor is not prosecuting work with such diligence as will assure completion within the times specified. Upon such determination, the District may terminate the Contractor's right to proceed with the performance of the Contract, or any separable part thereof, in accordance with Part V, General Conditions, Section

GC-15, Termination of Right to Proceed, herein. Said termination shall be without prejudice to any other remedies available to the District.

SC-3 HOURS OF WORK

- A. Hours of Work: Hours of work shall be from 7:00 a.m. to 6:00 p.m., Monday through Friday, excluding holidays.
- B. Weekend Work: No work shall be done on weekends unless specifically authorized by the District.
- C. Night Work: Night work shall not be allowed except under special circumstances. The Contractor may be permitted to work at night with approval of the District, in order to maintain the required progress or protect the work from the elements. The Contractor may also be required to prosecute the work at night if, at any time, the District shall deem it necessary for the progress of the work or if emergencies arise. The Contractor shall promptly comply with any such requirements made in writing by the District. When required by the District, the Contractor will be compensated in accordance with Part V, General Conditions, Section GC-30, Extra Work Payment. However, if the Contractor is required to work at night or on weekends to meet the time limits contained in the construction schedule and is not pursuing the work diligently, no additional compensation will be allowed.

Should any of the work be performed at night or where daylight is obscured or too dark, the Contractor shall, at its expense, provide artificial light sufficient to permit work to be carried on efficiently, satisfactorily, and safely, and to permit thorough inspection. The access to the place of work shall also be clearly illuminated. All wiring for electric light and power shall be installed and maintained in accordance with all applicable standards, securely fastened in place at all points, and shall be kept as far as possible from other electrical wires, telephone wires, signal wires, and wires used for firing blasts. For night work, if any be performed, the Contractor shall employ a crew organized and prepared for regular and continuous night work.

SC-4 BASIS OF PAYMENT

Contractor's attention is directed to Paragraph 3.04, Bid Items, of Section 01205, Measurement and Payment, of Part VII, Technical Specifications, for basis for payment and other payment information.

SC-5 LIQUIDATED DAMAGES

The time limits stated in the Contract are of the essence. It is agreed by the parties to the Contract that in case all the work called for under the Contract is not substantially completed before or upon the expiration of the time limits set forth in the Contract, damage will be sustained by the District, and that it is and will be impracticable to determine the actual damage which the District will sustain in the event of and by reason of such delay.

It is therefore agreed that Contractor shall pay to the District the following amount per day for each calendar day in excess of each milestone completion date required by the Contract, and the date the District deems the milestone work to be completed by the Contractor:

<u>MILESTONE</u>	<u>LIQUIDATED DAMAGE</u>
Online Operation	\$500/day
Substantial Completion	\$500/day

It is further agreed that the amounts stipulated are reasonable estimates of the damages that would be sustained by the District and Contractor agrees to pay such liquidated damages as herein provided as liquidated damages and not as penalty. In case the liquidated damages are not paid, Contractor agrees that the District may deduct the amount thereof from any money due to or that may become due Contractor by progress payments or otherwise under the Contract, or if said amount is not sufficient, recover the total amount from Contractor or its surety.

The assessment of liquidated damages under this provision shall not preclude recovery by the District of other damages subject to reasonable quantification, including consequential damages. Consequential and other damages not provided for by this liquidated damages provision may include, but are not limited to, first- and third-party claims for personal injuries and/or property damages, inverse condemnation, environmental claims, or regulatory fees or fines imposed in whole or in part due to Contractor's acts or failures to act.

SC-6 SUBSTANTIAL COMPLETION AND PROJECT MILESTONES

<u>MILESTONE</u>	<u>COMPLETION DATE</u>
Online Operation	October 1, 2023
Substantial Completion	December 1, 2023

Online Operation

The Online Operation milestone will be deemed complete when all interior and exterior welding and structural work is complete, all interior coating work is complete and the tank is filled, operational and in use.

Exterior coating and other Project work that does not impact putting the tank into operational service and does not put any of the other Project improvements at risk of damage may be completed after the Online Operation milestone.

Substantial Completion

When construction is sufficiently complete in accordance with the Contract so that the District can occupy or utilize all portions and all systems of the work for all of the uses for which said work was intended, and when Contractor has furnished the "as-built" drawings, operations and maintenance manuals, test and compliance certificates, equipment and system warranties, and all other documents required by the Contract, the work will be considered substantially complete.

This project will not be deemed substantially complete until all interior and exterior welding and structural work is complete, all coating work is complete and the tank is fully operational, filled and in use.

When the Contractor considers that the work is substantially complete, the Contractor shall request an inspection for substantial completion. When the District determines, on the basis of

the inspection, that all portions and all systems of the work are substantially complete, the District will prepare a Certificate of Substantial Completion that will establish the date of substantial completion of the work; shall state the responsibilities of the District and the Contractor for security, maintenance, operation, and insurance; and shall list the items remaining to be completed or corrected. Failure to include any items on such list does not alter the responsibility of the Contractor to complete all work in accordance with the Contract.

The District will have the right to restrict Contractor's use of the occupied portions of the work after the date of substantial completion, but the District will allow the Contractor reasonable access to complete or correct items required by the Contract.

The issuance of the Certificate of Substantial Completion for the work shall not relieve the Contractor of its obligation to promptly remedy any omissions and latent or unnoticed defects in the work covered by the Certificate of Substantial Completion.

A Certificate of Substantial Completion will not constitute acceptance of the work. A Certificate of Substantial Completion will fix the date for lowering the amount of liquidated damages to the value specified in the Contract for the period after substantial completion and before completion.

SC-7 SHUTDOWNS AND CONNECTIONS

The Contractor shall, at all times, conduct its operation so as to interfere as little as possible with existing District facilities and/or processes.

The Contractor shall allow for ten (10) days for the District to drain a tank after receiving notice from the Contractor.

Where required, the Contractor shall connect to existing facilities and/or processes as necessary to complete the Project. The Contractor shall give five (5) working days' advance notice and receive prior written approval from the District for all connections to existing facilities and/or processes, whether such connections are "live" or "inactive."

All work on connecting with, cutting into, and reconstructing existing pipes or structures shall be planned to interfere with the operation of the existing facilities for the shortest possible time when the demands on the facilities best permit such interference. In some cases, it may be necessary to work outside of normal working hours to meet these requirements. Before starting work that will interfere with the operation of existing facilities, the Contractor shall do all possible preparatory work and shall see that all tools, materials, and equipment are made ready and located at the job site. No connections shall be made without the District's prior approval.

SC-8 USE OF COMPLETED PORTIONS OF WORK

Whenever, as determined by the District, any portion of work performed by Contractor is in a condition suitable for use, the District may take possession of or use such portion.

Such use by the District will in no case be construed as constituting final acceptance and shall neither relieve Contractor of any of its responsibilities under the Contract, nor act as a waiver by the District of any of the conditions thereof, provided that Contractor shall not be liable for the cost of repairs, rework, or renewals which may be required due to ordinary wear and tear

resulting from such use. However, if such use increases the cost or delays the completion of remaining portions of work, Contractor shall be entitled to an equitable adjustment.

If, as a result of Contractor's failure to comply with the provisions of the Contract, such use proves to be unsatisfactory to the District, the District will have the right to continue such use until such portion of work can, without injury to the District, be taken out of service for correction of defects, errors, omissions, or replacement of unsatisfactory materials or equipment, as necessary for such work to comply with the Contract, provided that the period of such operation or use pending completion of appropriate remedial action shall not exceed four months unless otherwise mutually agreed upon in writing between the parties. The completion of corrections or replacements shall occur before acceptance of the Contract, unless otherwise mutually agreed upon in writing between the parties.

SC-9 SPECIAL SAFETY PRECAUTIONS

Contractor is hereby informed that work on this Project could be hazardous. Contractor shall carefully instruct all personnel working in potentially hazardous work areas as to potential dangers and shall provide such necessary safety equipment and instructions as are necessary to prevent injury to personnel and damage to property.

CONTRACTOR IS ADVISED THAT THE NATURE OF THE WORK SPECIFIED HEREIN MAY BE POTENTIALLY HAZARDOUS BECAUSE OF POTENTIAL CONFINED SPACES, CONDITIONS REQUIRING FALL PROTECTION, AND LEAD COATINGS.

SC-10 CONTRACTOR FACILITIES

Contractor shall, at all times, maintain all portions of the jobsite in a neat, clean, and sanitary condition at all times. The Contractor shall, as a minimum, conduct daily inspections to verify that requirements of this Section are being met.

The job site is located adjacent to a residential neighborhood. Contractor shall take reasonable precautions so as to not disturb the nearby residents.

Contractor's attention is directed to Section 01100, Paragraph 1.08, Temporary Facilities, of Part VII, Technical Specifications, regarding temporary facilities at the job site.

SC-11 SECURITY

The work site is an operational water treatment facility that will continue to be operational throughout the Contractor's work. Existing fences enclose all portions of the Project site for the protection and security of existing facilities. While it may be necessary for the Contractor to remove some of the fences to complete the work, the Contractor's operations shall not reduce the present protection and security. If the present fences are removed, an equivalent temporary continuous perimeter protection shall be provided, and new fence shall be installed in the locations shown, prior to completion of the work.

If needed for safety and security, Contractor, at its cost, shall construct temporary fencing to prevent unauthorized access to the work area. No existing fence or other existing enclosure about existing facilities shall be assumed by the Contractor to provide appropriate security for equipment, plant, or materials intended to be employed or incorporated in the work.

SC-12 STORAGE OF MATERIALS AND EQUIPMENT

The Contractor shall, at its expense, store and maintain all materials and equipment as specified in the Contract or, where not specified, in such a manner as to assure the preservation of their quality and fitness, including warehousing if required by the District, and so as to facilitate job-site safety and convenient inspection by the District. The Contractor shall not dispose, remove, or otherwise encumber any of the materials or equipment so stored except as authorized in writing by the District.

The Contractor shall be responsible for, and shall bear any and all risk of loss of, or damage to, any work and all materials and equipment until final acceptance under the Contract, unless such loss or damage results from the active negligence of the District or any act of God as defined herein.

SC-13 SALVAGE AND DISPOSAL OF MATERIALS

- A. Salvage: Existing items to be salvaged shall remain the property of the District. Items to be reinstalled in the work shall be refurbished as required before reinstallation. Items to be salvaged shall be carefully removed and handled in such a manner as to avoid damage and shall be delivered to storage at a location designated by the District.
- B. Disposal: Existing materials and equipment to be demolished, removed, and disposed as noted on the drawings and all trash such as broken concrete, wood blocking, shipping containers, etc., resulting from the Contract work shall be disposed off District property at Contractor's expense. District-leased dumpsters and other disposal containers on the District's property shall not be used by Contractor.

SC-14 NOT USED

SC-15 NOT USED

SC-16 ACCESS AND COOPERATION

The Contractor's attention is drawn to the fact that during the course of the work of this Contract, existing facilities will be used and maintained by District's personnel. The Contractor shall coordinate its work in such a way as to interfere as little as possible with the routine work of existing facility operation consistent with the necessity for making the connections as specified and as shown on the Project Drawings. The intent of this item is also that the Contractor's work force shall be excluded from access to and use of existing facilities except in direct pursuit of the work of this Contract, unless approved by the District. The Contractor shall provide safe access at all times to all existing facilities for operating personnel and equipment.

Since the project site is a secure, operational facility, Contractor shall work with the District to coordinate daily, secure access into the site.

SC-17 PROTECTION AND RESTORATION OF PROPERTY

Project work will occur on District property at an operational water treatment facility. Contractor shall take all measures necessary to protect all existing facilities, including but not limited to operational tanks, pipelines, valves, pump station and security facilities. Damage to any property or facilities resulting from Contract work shall be repaired by the Contractor, at its sole

cost. In as much as it is reasonably possible, Contractor, at its sole cost, shall restore the area affected by Project work to its condition prior to construction.

The Contractor shall exercise extreme caution in working in the area adjacent to existing facilities. It is essential to public health and safety that all the existing facilities be maintained in service at all times.

The Contractor shall conduct its operations as not to close or obstruct any portion of any railroad, highway, road, or other property until permits therefor have been obtained from the governmental or other authorities having jurisdiction thereof. If any of the above are required to be kept open and are damaged or rendered unsafe by the Contractor's operations, the Contractor shall, at its expense, make such repairs and provide such temporary guards, bridges, lights, and other signals as necessary or required for public safety and as will be acceptable to the governmental or other authorities having jurisdiction thereof. Fences that interfere with any work may, upon prior written approval of the District, be removed by the Contractor but must then be restored to their original condition prior to final acceptance. Such removing and restoring shall be by and at the expense of the Contractor.

Care shall be exercised by the Contractor to prevent damage to adjacent walks, streets, culverts, and gutters; where equipment will pass over these obstructions, suitable planking shall be placed.

The Contractor shall preserve and protect all cultivated and planted areas, and vegetation such as trees, plants, shrubs, and grass on or adjacent to the premises, which, as determined by the District, do not reasonably interfere with the performance of work. The Contractor will be held responsible for damage to any such areas and vegetation and for unauthorized cutting of trees and vegetation, including without limitation, damage arising from the performance of its work through operation of equipment or stockpiling of materials. All costs in connection with any repairs or restoration necessary or required by reason of any such damage or unauthorized cutting shall be borne by the Contractor.

SC-18 STORM WATER POLLUTION PREVENTION

Contractor shall implement any best management practices necessary to ensure no contamination of the adjacent creek.

In addition to the above, Contractor shall take the following measures:

A. General

1. **Prevention:** The Contractor shall prevent the pollution of storm drain systems and creeks on or near the construction Project site(s) resulting from the construction. The Contractor shall keep pollutants out of storm drains by reducing the possibility of accidental discharge of materials and wastes, by reducing erosion and sedimentation, and by any action as required. The Contractor shall train all employees and subcontractors on the storm water pollution prevention requirements contained in these Specifications and ensure that all employees and subcontractors are aware of the consequences as described in paragraph A.3. below. The Contractor shall include appropriate subcontract provisions to ensure that these requirements are met by all subcontractors.

2. Notification: If the Contractor causes or permits the spillage or overflow of any oil, or petroleum product, hazardous substance, contaminant, waste or wastewater, including overflows or releases of untreated or treated (partially or fully) wastewater, and backups into buildings and on private property, the Contractor shall notify the District as soon as possible to the extent notification can be provided without substantially impeding cleanup or other emergency measures. In no event shall such notification be later than one (1) hour after knowledge of the occurrence.
3. Cleanup: Immediately upon gaining knowledge of such spillage, overflow, or discharge, the Contractor shall eliminate the cause of the spillage, overflow, or discharge and take action to minimize any damages. The Contractor shall also immediately implement a cleanup program. The cleanup, including sampling and testing required by regulatory agencies to determine the nature and level of contamination, shall be performed and completed to the satisfaction of the various regulatory agencies involved and the District, at the expense of the Contractor. If the Contractor's response is not satisfactory to the District, the District may, at its own discretion, mobilize to eliminate the cause of the overflow and implement a cleanup program, including any necessary sampling and testing. District costs of cleanup efforts shall be at the Contractor's expense and collected at the discretion of the District. Any fines, penalties, and/or subsequent actions imposed upon the District and/or the Contractor by regulatory agencies related to the spillage, overflow, or discharge and any subsequent monitoring, testing, and reporting, as required by regulatory agencies, shall also be at the expense of the Contractor. The Contractor shall keep a stockpile of spill cleanup materials, such as rags or absorbents, readily accessible on site. The quantity of cleanup materials shall be appropriate in consideration of the risk of an occurrence of a spill, overflow, or discharge.

B. Management of Nonhazardous Material and/or Waste

1. Designated Area: The Contractor shall propose designated areas of the Project site, for approval by the District, suitable for material delivery, storage, and waste collection that to the maximum extent practicable are near construction entrances and away from catch basins, gutters, drainage courses, and creeks.
2. Backfill or Excavated Material: The Contractor shall not allow backfill or excavated material to enter the storm drains or creeks. When rain is forecast within 24 hours or during wet weather, the Contractor may be required to cover such material with a tarpaulin and to surround the material with sand bags.
3. Disposal: At the end of each working day, the Contractor shall collect all scrap, debris, and waste material, and dispose of such materials properly. The materials may be stored in the Contractor's yard in stockpiles or placed in dumpsters. The Contractor shall inspect dumpsters for leaks and replace or repair dumpsters that leak. The Contractor shall not discharge water from cleaning dumpsters on site. The Contractor shall arrange for regular waste collection before dumpsters overflow.

C. Management of Hazardous Material and/or Waste

1. Storage: The Contractor shall label and store all hazardous materials, such as pesticides, paints, thinners, solvents, and fuels, and all hazardous wastes, such as waste oil and antifreeze, in accordance with all applicable state and federal regulations. The Contractor shall store all hazardous materials and all hazardous wastes in accordance with secondary containment regulations. All such materials and wastes shall be covered, as needed, to avoid rainwater becoming polluted with hazardous constituents, which could result in potential management of collected rainwater as hazardous waste. The Contractor shall keep an accurate, up-to-date inventory, including Material Safety Data Sheets (MSDS), of hazardous materials and hazardous wastes stored on site.
2. Usage: When rain is forecast within 24 hours or during wet weather, the Contractor shall refrain from applying chemicals in outside areas. The Contractor shall follow material manufacturer's instruction regarding uses, protective equipment, ventilation, flammability, and mixing of chemicals. The Contractor shall post warning signs in areas treated with chemicals.
3. Disposal: The Contractor shall arrange for regular hazardous waste collection to comply with time limits on storage of hazardous wastes. The Contractor shall dispose of hazardous waste in accordance with Part V, General Conditions, Section GC-25, Contaminated Soil/Materials. The Contractor shall not wash any spilled material into streets, gutters, storm drains, or creeks and shall not bury spilled hazardous materials. The Contractor shall report any hazardous material spills to the District in accordance with paragraph A.2 above.

D. Vehicle/Equipment Cleaning, Maintenance, and Fueling

1. General: The Contractor shall inspect vehicles and equipment arriving on site for leaking fluids and shall promptly repair leaking vehicles and equipment. Drip pans shall be used to catch leaks until repairs are made.
2. Cleaning: The Contractor shall perform vehicle or equipment cleaning with water only in a designated, bermed area that will not allow rinse water to run off site into streets, gutters, storm drains, or creeks. Soaps, solvents, degreasers, steam-cleaning equipment, or equivalent methods shall not be allowed.
3. Maintenance and Fueling: The Contractor shall perform maintenance and fueling of vehicles or equipment in areas that will not allow run-on of storm water or runoff of spills to storm drains and that provide for confined cleanup. Examples are working in bermed areas or utilizing drip pans. The Contractor shall not contaminate the soils or groundwater with such maintenance and fueling activities.

The Contractor shall use secondary containment, such as a drip pan, to catch leaks or spills any time that vehicle or equipment fluids are dispensed, changed, or poured, and shall clean up leaks and spills of vehicle or equipment fluids immediately and dispose of the waste and cleanup materials as hazardous waste, as described in paragraph C.3 above.

G. Concrete, Grout, and Mortar Waste Management

1. Concrete Truck/Equipment Washout: The Contractor shall not wash out concrete trucks or equipment into streets, gutters, storm drains, or creeks. The Contractor shall perform washout of concrete trucks or equipment off site or in a designated area on site where the water will flow onto dirt or into a temporary pit in a dirt area. The Contractor shall let the water percolate into the soil and dispose of the hardened concrete in a trash container. If a suitable dirt area is not available, the Contractor shall collect the wash water and remove it off site.
2. Exposed Aggregate Concrete Wash Water: The Contractor shall avoid creating runoff by draining water from washing of exposed aggregate concrete to a dirt area. If a suitable dirt area is not available, the Contractor shall filter the wash water through straw bales or equivalent material before discharging to a storm drain. The Contractor shall collect sweepings from exposed aggregate concrete for disposal.

PART VII TECHNICAL SPECIFICATIONS

INDEX

Section	Title
01100	Scope and Control of the Work
01205	Measurement and Payment
09905	Protective Coatings
13010	Upgrades to the Existing Tank
13020	Replace Water Tank Roof
16600	Impressed-Current Cathodic Protection System

Technical Specifications for:

TWAIN HARTE COMMUNITY SERVICES DISTRICT
22912 Vantage Pointe Dr.
Twain Harte, CA
(209) 586-3172

Prepared by:

ADVANTAGE TECHNICAL SERVICES, INC.
6661 Fern Canyon Road
San Luis Obispo, CA 93401
805-595-2282

February 2023

CERTIFICATION

In accordance with the provisions of Section 6735 of the Business and Professions Code of the State of California, these specifications have been prepared by or under the direction of the following Professional Engineers licensed in the State of California:



William D. Bellis, PE
55334, Exp. 12/31/2024



Approved by:



Tom Trott, PE
71446, Exp. 12/31/2023

Section 01100

SCOPE AND CONTROL OF THE WORK

PART 1 - GENERAL

1.01 SCOPE

The project generally includes upgrading appurtenances, replacing roof and roof structure and recoating the interior and exterior of one 1-million-gallon welded water tank (known as MG#2) and other items specified herein and as shown on the Contract Documents. The following sections further define the scope of the Work as detailed within these specifications (planning and the actual order of work is the responsibility of the Contractor):

- A. The Contractor will provide any required sampling and testing of existing interior coatings known to contain lead and other heavy metals and lead based exterior coatings that are known to contain lead and other heavy metals. Employee protections for disturbance of coatings containing lead and other heavy metals shall be included in all project planning and execution.
- B. The Contractor will complete engineering and planning and will provide submittals pursuant to these specifications.
- C. The Contractor will fabricate and shop coat replacement roof and appurtenances as specified.
- D. The District will provide access. The District provided work area is limited to the fenced unpaved tank site.
- E. The District will provide any applicable building permits.
- F. The Contractor will notify the District at least two weeks in advance of the start of demolition to allow the draw-down and use of the water in the existing tank.
- G. The District will draw-down the water in the existing tank and remove from service. The District will notify the Contractor when the tank has been removed from service and rehabilitation may be started. Some water and sediment will remain in the tank.
- H. The Contractor will mobilize to the site and will complete the specified work items including but not limited to demolition, repairs, upgrades, preparation and coating on the tank.
- I. The Contractor will provide full containment of dust, mists and other during preparation and coating. Containment of dusts and mists etc. will be continued until the project is complete and the captured dusts/materials are transferred to the appropriate disposal site.
- J. The Contractor will coordinate with the Owner for use of a 30' x 40' space that is available for storage between phases and otherwise demobilize all equipment construction materials, stabilize the site and return control of the site to the District.
- K. The interior coatings of the tank will be allowed to cure as recommended by the coating manufacturer.

- L. The Contractor will provide disinfection of interior surfaces as specified and seal the tank.
- M. The District will fill the newly painted tank and provide VOC and bacteriological testing and put the newly painted tank into service as appropriate.
- N. The Contractor will sample, test, provide transport and recycle spent abrasive
- O. The Contractor will sample, test, provide transport and dispose of any coatings or materials not included with the spent abrasive.
- P. The Contractor will demobilize all construction equipment, construction materials, stabilize the site and return control of the site to the District.
- Q. The Contractor will provide a one year warranty on the Work pursuant to these specifications.

1.02 RELATED WORK SPECIFIED ELSEWHERE

- A. Section 01205, Measurement and Payment
- B. Section 09800, Protective Coatings
- C. Section 13020, Replace Water Tank Roof
- D. Section 16700, Impressed Current Cathodic Protection System

1.03 SUBMITTALS

- A. Submittals shall be provided in accordance with these Special Provisions. Submittals shall be provided electronically in "PDF" format. The Contractor shall maintain a full set of approved submittals on the job site.

The Contractor shall provide submittals before the pre-job conference. No work shall be done on items needing submittal approval until the material or plan is approved by the Owner.

Submittals shall be submitted to:

Twain Harte Community Services District

ttrott@twainhartecsd.com

Attn: Tom Trott, P.E.

General Manager

Twain Harte Community Services District

P.O. Box 649

Twain Harte, CA 95383

- B. The Contractor shall provide a Project Safety Plan prepared under the direction of and **certified by a Certified Safety Professional (CSP)** as determined by the Board of

Certified Safety Professionals. The intent of the plan is to develop and document measures, appropriate to the Contractor's means and methods, which assure regulatory compliance. The plan shall be submitted before the pre-construction conference. A copy of the Project Safety Plan shall be on site during the course of the project. Payment for providing and implementing the Safety Plan shall be considered as included in the various contract prices paid and no additional compensation will be allowed.

1.04 HEALTH, SAFETY AND ENVIRONMENTAL CONTROLS

- A. The project goals are to complete the work with no injuries, spills or other environmental incidents. The Contractor shall be responsible for conducting the work in a manner that protects project personnel, the public and the environment. The Contractor shall provide qualified persons and implement appropriate programs to control all aspects of the work including worker and public health, safety and environmental protection.
- B. The Contractor shall conduct regular safety meetings with continuous review potential hazards associated with the project. Steps shall be taken to mitigate hazards and maintain a safe workplace. Known project safety and environmental hazards include the following:
 - 1. Falls
 - 2. Confined spaces
 - 3. Eye injury including arc burn
 - 4. Venomous snakes including rattle snakes
 - 5. Poisonous spiders including black widow and brown recluse
 - 6. Wild fire associated with grinding, welding and other equipment or ignition sources
 - 7. Fire or explosion associated with flammable fuels or solvents
 - 8. Vehicle accidents
 - 9. Spills from leaking equipment or storage containers
 - 10. Introduction of non-native species
 - 11. Work on and around existing lead based paints
 - 12. Work around paints including volatile organic compounds

1.05 NOISE

Noise generated from equipment operating overnight including generators, pumps and dehumidification shall not exceed 75 dB at all property lines.

1.06 OSHA COMPLIANCE.

- A. Contractor shall comply with all applicable regulations including state and federal OSHA and these Special Provisions.

- B. Contractor is responsible for complying with Cal/OSHA regulations for lead in construction in accordance with California Code of Regulations, California Title 8, Section 1532.1.
- C. The costs for complying with all OSHA requirements shall be considered as included in the various contract prices paid and no additional compensation will be allowed. Contractors are encouraged to take lead samples in advance by arrangement with the owner.

1.07 LEAD

- A. The facilities included in this project were constructed prior to 1978. Cal/OSHA requires compliance with 1532.1 if the paint contains lead at any level. The exterior coatings are known to be lead based coatings that also contain other heavy metals. Interior coatings are known to contain heavy metals.
- B. The Owner assumes no responsibility for sampling or test results. All work involving the removal of lead containing coatings and the disposal of such removed material shall be in strict accordance with all applicable Local, State and Federal regulations and guidelines including notification, removal and containment techniques, proper transportation and disposal, and worker protection and monitoring.
- C. The Contractor is responsible to test the composite waste from the project to determine proper disposal. A copy of all test results shall be furnished to the Owner.
- D. For waste requiring the preparation of a hazardous waste manifest and waste shipment record, the Contractor shall prepare an accurate hazardous waste manifest and waste shipment record for signing by the Engineer. Neither the Contractor nor his employees shall sign the waste manifests or waste shipment records as the generator's representative. The Contractor shall provide the Owner with a certified weight ticket for each shipment of hazardous waste. If any waste is shipped to a disposal facility outside of California, the transporter and disposal facility shall complete and sign and distribute California's Hazardous Waste Manifest in the same manner as required by California law for the disposal facilities inside California.
- E. The Contractor will be responsible for any cleanup of areas where materials containing lead, heavy metals or other hazardous and non-hazardous materials have been released during the job. The Contractor shall assume all costs for such cleaning.

1.08 TEMPORARY FACILITIES.

- A. Power. The Contractor shall provide, at no additional cost to the Owner, all construction power used at the project sites.
- B. Sanitary Facilities. The Contractor shall make arrangements and provide for adequate portable toilet facilities at the site of work. The Contractor shall maintain the sanitary facilities in acceptable condition from the beginning of work until completion and shall remove the facilities and disinfect the premises.
- C. Water. The District will provide construction water used at the project site.

1.09 CONSTRUCTION DETAILS.

- A. The tanks are located in Twain Harte, CA. The facilities serve a predominantly residential community.
- B. Working hours shall be adjusted to maximize work hours during coating operations.
- C. Tank Draining. Prior to the start of construction, Owner staff shall empty the Tank. The tank will be out of service and drained but some water will remain. The Contractor shall remove the remaining water as needed to facilitate the start of work.

1.010 ISOLATION OF EQUIPMENT

- A. The piping and equipment adjacent to the tank will be in service during the work. The Contractor shall work with plant operations personnel to assure safe working conditions and prevent damage to property and equipment.
- B. The Owner shall be responsible for lockout/tag out of all power on equipment. The Contractor shall confirm lockout/tag out before proceeding with work.

**PART 2 - PRODUCTS
NOT APPLICABLE**

PART 3 - EXECUTION

3.01 HOUSEKEEPING AND CLEANUP

- A. At the end of each work day, dust and abrasive shall be removed from the surfaces and surrounding areas. Spent abrasive shall be stored in temporary storage containers on site pursuant to Best Management Practices and Best Pollution Prevention Practices listed under federal and state guidelines.
- B. The site shall be maintained free of unnecessary accumulations of tools, equipment, surplus materials, and debris. Equipment maintenance and spill prevention procedures shall be adequate to prevent spills and leaks.
- C. Upon completion of the work, the Contractor shall remove all excess materials, equipment, containers, and waste from the job site. Coating spots or stains shall be removed from adjacent surfaces and surfaces repaired if needed. As work proceeds, promptly remove all coating that is spilled, splashed, or splattered. Collect empty containers, rags, waste material, and debris and store or remove from the site as appropriate.

3.02 ACCESS, CONTAINMENT AND PROTECTION

- A. The Contractor shall provide scaffolding or other access and fall protection anchors to allow safe access for Contractor personnel, inspection personnel and others as appropriate
- B. The tank is situated near open lands and creeks and all surface drains and swales lead directly onto the adjacent land, or to creeks and the ocean. Contractor shall protect all work sites and all drainage inlets from pollutants and illegal discharges.

- C. The work will be conducted in and around operational equipment and adjacent to residences. The Contractor shall provide containment or mitigation of air-born dust, overspray and other contaminants to protect the existing equipment, facilities and neighboring properties from dust, overspray pursuant to regulatory requirements.

END OF SECTION

Section 01205

MEASUREMENT AND PAYMENT

PART 1 - GENERAL

This Section describes the methods of measurement and payment for the specific bid items associated with Work on the million-gallon water tank known as MG#2. All other provisions of the Contract Documents which relate to measurement and payment are applicable, except that where conflicts occur between this section and other provisions of the technical specifications or reference specifications, this measurement and payment section shall prevail.

PART 2 - PRODUCTS NOT APPLICABLE

PART 3 - EXECUTION

3.01 METHOD OF PAYMENT

- A.** Payment will be made on the basis of the unit prices or lump sums bid for the various items as called for on the Bid Sheet(s) and included in the Contract as awarded. The quantities given in the Proposal and Contract forms are approximate only and are given as a basis for the comparison of bids, and the Owner does not expressly or by implication agree that the actual amount of work will correspond therewith, but reserves the right to increase or decrease the amount of or any class or portion of the Work or to omit portions of the Work as may be deemed necessary or advisable by the Engineer.

3.02 MEASUREMENT OF QUANTITIES

- A.** Materials paid for by the ton shall be weighed on public scales or other scales for which the State Bureau of Weights and Measures has issued a certificate of inspection which is available to the Engineer.
- B.** Full compensation for all expenses involved in conforming to the above requirements for weighing materials shall be included in the prices for the materials being weighed, and no additional allowance will be made therefore.
- C.** The quantity of materials paid for by the lineal foot, square foot or square yard shall be determined by horizontal measurement.

3.03 SCOPE OF PAYMENT

- A.** The Contractor shall accept the compensation as herein provided as full payment for furnishing all materials, labor, tools, and equipment necessary to complete the Work, and for performing all work contemplated and embraced under the Contract; also, for loss or damage arising from the nature of the Work, or from the action of the elements, except as

heretofore provided, or from any unforeseen difficulties which may be encountered during the prosecution of the Work, until the final acceptance by the District, and for all risks of every description connected with the prosecution of the Work; also, for all expenses incurred in consequence of the suspension or discontinuance of the Work as herein specified; and for completing the Work according to the Plans and Specifications. Neither the payment of any estimate nor of any retained percentage shall relieve the Contractor of any obligation to make good any defective work or materials.

3.04 BID ITEMS

A. Mobilization and Construction Coordination

1. Description

This work includes the furnishing of all tools, equipment, labor and materials required to accomplish all of the following Work within the limits designated on the plans or as directed by the Engineer in accordance with the plans and specifications. The Work includes but is not limited to the following:

- a. The Contractor shall develop a construction plan for the Work with means and methods that allow completion of the work pursuant to these specifications using the District's limited space of the fenced tank site for the Work or shall, independently from the District, acquire any temporary easements from landowners that are necessary for stockpile of materials, or facilitation of completion of the Work. The construction plan shall include all work for both tanks.
- b. Portable restroom(s) shall be on site prior to, or at the time of, the start of mobilization and shall remain on site during all on-site Work.
- c. Mobilization – Contractor shall move in and set up all equipment, provision for power, materials, etc. as necessary to complete all aspects of this project. This item also includes the cost of all bonds, insurance, and Permits for the Project.
- d. Easements – The Contractor may determine the location, type, extent and value to the Contractor of any temporary easement(s), which may facilitate completion of the Work, which is beyond the District's access easement and fenced tank site shown in the Plans and Specifications.
- e. Construction Schedule – The Contractor is responsible for preparing, amending, implementing, and complying with a construction schedule for all Work on this project. The initial schedule shall be submitted to the Engineer at the time of the award of the contract. The schedule shall be amended, and submitted to the Engineer, as necessary if progress varies significantly from the schedule and at a minimum, every month.
- f. Construction Water – The District will provide access to construction water.
- g. Submittals – The Contractor shall provide the submittals and associated planning and engineering including, field verification, structural calculations, shop

drawings, materials data sheets, MSDS, certificates of compliance and other submittals required by the Work and these specifications.

- h. Utility Coordination – The Contractor is responsible for all coordination effort with regards to utilities on the project including temporary service interruptions, tie-ins, etc. and scheduling the inspection of all Contractor Work. The Contractor shall be responsible for any financial claims associated with missed inspections, repeat inspections, or any costs associated with re-working portions of the project due to failed inspections or lack of inspections based on the Contractors failure to schedule and follow through with same.
- i. Project Controls- A Health and Safety Plan for worker protection, including working with lead based paints, developed under the direction and signed by a Certified Safety Professional shall be submitted and kept on site for the duration of the project. The plan shall be for all Work on this project. The plan shall address known hazards including excavation safety, confined space permit controls, lead, fall protection and fire prevention.
- j. An Environmental Health Protection plan (including storm water pollution prevention best management practices) for all Work on this project shall be developed under the direction of and signed by a licensed P.E. shall be submitted and kept on the site for the duration of the project.

2. Measurement

Measurement of Work associated with Bid Item **No. 1** will be based upon completion of such work as a lump sum.

3. Payment

Payment for this bid item will be made at the lump sum named in the Bid Schedule under Bid Item **No.1**, which price shall constitute full compensation for all such work. Payment for “Mobilization and Construction Coordination” will be made in the form of a single, lump-sum, non-pro-ratable payment, no part of which will be approved for payment under the Contract until all mobilization items listed herein have been completed as specified. The scope of the work included under this bid item shall include the obtaining of all bonds, insurance, permits, submittals, and moving tank construction equipment (including crane, power generation and welders) onto the site.

All submittals shall conform to the requirements of the General Conditions and Specifications and be approved by the Engineer.

No payment for any of the listed “Mobilization and Construction Coordination” work items will be made until all of the listed items have been completed to the satisfaction of the Engineer.

The aforementioned amount will be retained by the Owner as the agreed, estimated value of completing all of the mobilization items listed. Any such retention of money for failure to complete all such mobilization items as a lump-sum item shall be in addition to the retention of any payments due to the Contractor.

B. Replace Tank Roof

1. Description

This Work includes the furnishing of all tools, equipment, labor and materials required to accomplish all of the following Work within the limits designated on the plans or as directed by the Engineer in accordance with the plans and specifications. The Work includes but is not limited to the following:

- a. Field verification of tank dimensions
- b. Engineering of any required temporary supports, roof structure, tank connections and foundation, shop drawings, submittals and documentation of contract compliance.
- c. Shop fabrication
- d. Shop coating
- e. Removal and on-site storage of lead based paints
- f. Remove and dispose of existing cathodic protection system
- g. Temporarily support the roof, shell and other portions of the tank and appurtenances as required.
- h. Demolition, removal and recycling of existing roof (includes roof plate and structure down to and including base plates) and all other materials removed as a portion of this work
- i. Erection of new roof structure and all associated elements for a complete roof
- j. Quality control
- k. Testing of welds
- l. Complying with all applicable federal, state, and local regulations

2. Measurement

Measurement of Work associated with Bid Item **No. 2** will be based upon completion of this work as a lump sum. The measurement shall be made by the contractor and verified by the Owner's representative.

3. Payment

Payment for this bid item will be made at the lump sum named in the Bid Schedule under Bid Item **No. 2**, which price shall be made on a percent complete basis based on the lump sum amount for this item. The lump sum cost shall constitute full compensation for furnishing all labor, materials, tools, and equipment associated with performing all Work involved in providing Work under this bid item in place, operational, and in conformance with the plans & specifications.

C. New Guardrail, Roof Hatch, Roof Vent, Level Gauge and Roof Fall Protection System

1. Description

This Work includes the furnishing of all tools, equipment, labor and materials required to accomplish all of the following Work within the limits designated on the plans or as directed by the Engineer in accordance with the plans and specifications. The Work includes but is not limited to the following:

- a. Field verification of related existing tank and appurtenance dimensions.
- b. Engineering of guardrail, roof hatch, vent, roof fall protection system and associated appurtenances, shop drawings, submittals and documentation of contract compliance
- c. Removal and on-site storage of lead based paints
- d. Demolition, removal and recycling of existing guardrail, roof hatch and all other materials removed as a portion of this work
- e. Welded installation of a 1/4" thick cover plate at the exterior ladder opening where the existing roof hatch was removed
- f. Fabrication and installation of a new roof hatch at a new location (away from the exterior ladder opening)
- g. Fabrication and installation of new roof guardrail
- h. Fabrication and installation of (2 sets) fall protection anchors and cables
- i. Fabrication and installation of a new level gauge
- j. Fabrication and installation of new mid platform grating
- k. Finishing welds and other surfaces in preparation for coating
- l. Fabrication and installation of new roof vent
- m. Preparation and coating of new appurtenances.
- n. Quality control
- o. Complying with all applicable federal, state, and local regulations

2. Measurement

Measurement of Work associated with Bid Item **No. 3** will be based upon completion of this work as a lump sum. The measurement shall be made by the contractor and verified by the Owner's representative.

3. Payment

Payment for this bid item will be made at the lump sum named in the Bid Schedule under Bid Item **No. 3**, which price shall be made on a percent complete basis based on the lump

sum amount for this item. The lump sum cost shall constitute full compensation for furnishing all labor, materials, tools, and equipment associated with performing all Work involved in providing Work under this bid item in place, operational, and in conformance with the plans & specifications.

D. New Climbers Safety Device

1. Description

This Work includes the furnishing of all tools, equipment, labor and materials required to accomplish all of the following Work within the limits designated on the plans or specifications or as directed by the Engineer in accordance with the plans and specifications. The Work includes but is not limited to the following:

- a. Field verification of dimensions and existing device/rail type
- b. Submittals for the new climber's safety device to match type of existing.
- c. New safety devices for upper ladder and new lower ladder sections.
- d. Removal and recycling of the existing safety device rail
- e. Installation of new climber's safety device rails
- f. Delivery of climbing device, appurtenances and instructions to Owner

2. Measurement

Measurement for Bid Item **No. 4** Work will be based upon completion of this work as a lump sum. The measurement shall be made by the contractor and verified by the Owner's representative.

3. Payment

Payment for Bid Item **No. 4** shall be made only when all portions of the work are complete. The lump sum cost shall constitute full compensation for furnishing all planning, acquisition, labor, materials, tools, and equipment associated with performing all Work involved in providing the system in place, operational, and in conformance with the plans & specifications.

E. New Low Section of Caged Exterior Ladder and Door

1. Description

This Work includes the furnishing of all tools, equipment, labor and materials required to accomplish all of the following Work within the limits designated on the plans or as directed by the Engineer in accordance with the plans and specifications. The Work includes but is not limited to the following:

- a. Field verification of dimensions of existing upper portion of ladder, existing mid-platform and new low section of caged exterior ladder and door.

- b. Engineering of new low section of caged ladder, ladder security door and associated appurtenances to mate to existing mid-platform, shop drawings, submittals and documentation of contract compliance
- c. Removal and on-site storage of lead-based paints
- d. Fabrication and installation of a new low section of exterior ladder with cage and added guardrails on the platform to provide safe access and meet regulatory requirements.
- e. Fabrication and installation of a new ladder security door
- f. Finishing welds and other surfaces in preparation for coating
- g. Quality control
- h. Compliance with all applicable federal, state, and local regulations

2. Measurement

Measurement of Work associated with Bid Item **No. 5** will be based upon completion of this work as a lump sum. The measurement shall be made by the contractor and verified by the Owner's representative.

3. Payment

Payment for this bid item will be made at the lump sum named in the Bid Schedule under Bid Item **No.5** which price shall made on a percent complete basis based on the lump sum amount for this item. The lump sum cost shall constitute full compensation for furnishing all labor, materials, tools, and equipment associated with performing all Work involved in providing Work under this bid item in place, operational, and in conformance with the plans & specifications.

F. Interior Coatings

1. Description

This Work includes the furnishing of all tools, equipment, labor and materials required to accomplish all of the following Work within the limits designated on the plans or as directed by the Engineer in accordance with the plans and specifications. The Work includes but is not limited to the following:

- a. Preparation of interior surfaces of the existing tank and appurtenances for coatings
- b. Store (on site) spent abrasive
- c. Application of coatings on interior surfaces and appurtenances
- d. Preparation and application of coatings on interior surfaces of the underground and aboveground piping (first six inches from tank)

- e. Preliminary wash of all interior surfaces, piping and components prior to disinfection
- f. Disinfection of tank interior surfaces
- g. Disinfection of piping and any other surfaces, affected by the work that are within the potable water storage and distribution system.
- h. Protecting and repairing coatings damaged during disinfection and other work
- i. Quality control

2. Measurement

Measurement of Work associated with Bid Item **No. 6** will be based upon completion of this work as a lump sum. The measurement shall be made by the contractor and verified by the Owner's representative.

3. Payment

Payment for this bid item will be made at the lump sum named in the Bid Schedule under Bid Item **No. 6**, which price shall made on a percent complete basis based on the lump sum amount for this item. The lump sum cost shall constitute full compensation for furnishing all labor, materials, tools, and equipment associated with performing all Work involved in providing Work under this bid item in place, operational, and in conformance with the plans & specifications.

G. Exterior Coatings

1. Description

This Work includes the furnishing of all tools, equipment, labor and materials required to accomplish all of the following Work within the limits designated on the plans or as directed by the Engineer in accordance with the plans and specifications. The Work includes but is not limited to the following:

- a. Removal and containment and handling of existing lead-based coatings
- b. Preparation and coating of exterior surfaces of the existing tank
- c. Quality control

2. Measurement

Measurement of Work associated with Bid Item **No. 7** will be based upon completion of this work as a lump sum. The measurement shall be made by the contractor and verified by the Owner's representative.

3. Payment

Payment for this bid item will be made at the lump sum named in the Bid Schedule under Bid Item **No. 7**, which price shall made on a percent complete basis based on the lump sum amount for this item. The lump sum cost shall constitute full compensation for

furnishing all labor, materials, tools, and equipment associated with performing all Work involved in providing Work under this bid item in place, operational, and in conformance with the plans & specifications.

H. Welded Patches

1. Description

This Work includes the furnishing of all tools, equipment, labor and materials required to accomplish all of the following Work within the limits designated on the plans or as directed by the Engineer in accordance with the plans and specifications. The Work includes but is not limited to the following:

- a. Provide submittals including welding procedures
- b. Fabricate patch plates up to 2 sq. ft. each.
- c. Remove lead-based paint & seal weld patch plates on tank to seal existing shell vents and other miscellaneous holes as directed by the Owner or Owner's Representative.

2. Measurement

Measurement for Bid Item **No. 8** Work will be based upon completion of these items on a unit cost basis for each complete excavation as identified on the plans and in the contract documents. The measurement shall be made by the contractor and verified by the Owner's Representative.

3. Payment

Payment for Bid Item **No. 8** shall be made on a unit cost basis. The unit cost shall constitute full compensation for furnishing all labor, materials, tools, and equipment associated with performing all Work involved in providing the Work associated with this Bid Item in place, operational, and in conformance with the plans & specifications.

I. Demobilization

1. Description

This work includes the furnishing of all tools, equipment, labor and materials required to accomplish all of the following Work within the limits designated on the plans or as directed by the Engineer in accordance with the plans and specifications. The Work includes but is not limited to the following:

- a. Public Safety – The Contractor shall concern himself with public safety at all times during the life of this contract. Work area shall be clearly identified. Public access through the project shall be by means of well established and delineated corridors. Materials shall be stockpiled in such a manner as to assure no hazard to the public, District Facilities, District Operations or the environment. Tools and equipment shall be likewise kept locked and out of reach. Work area shall be kept free of garbage and other waste.

- b. Dust Control – The Contractor shall comply with all County and other regulatory requirements for dust control. Contractor shall provide adequate personnel and equipment as necessary to abate all dust, which results from either his operation or created by a portion of the Work of this project. Dust control measures shall be in effect during the entire length of this contract including weekends and holidays. Contractor shall designate a contact person responsible for responding to any calls regarding dust issues and implementing dust control measures.
- c. Demobilization – Contractor shall move off all equipment, materials, etc. as necessary to complete all aspects of this project.
- d. Handle, sample, test, transport and recycle spent abrasive which will contain lead and other heavy metals from existing coatings
- e. Lead based coatings, removed as a portion of the Work, shall remain the property of the Owner. The Contractor shall handle, sample, test, provide licensed transportation and dispose of any lead based (or heavy metal containing) coatings, removed as a portion of this work and not specified for recycling as a part of the spent abrasive.
- f. Construction Clean-Up – The Contractor is responsible for leaving the project areas in suitable condition for operation. It is imperative that all contractor Work, stockpile, storage, and equipment areas be completely clean and free of foreign material, materials removed or replaced as part of this work, gravel, aggregate base, broken asphalt, pipe, hardware, packing material, welding debris, and concrete when the Work is complete. All said material shall be picked up and removed from the site and not scattered. All removals from the site shall be done so in a legal manner. Contractor is responsible for all costs associated with loading, hauling, and dumping including any required permits, fees, etc
- g. Daily housekeeping and site control.
- h. Maintenance of storm water pollution prevention plan controls.
- i. The Contractor shall provide slope stabilization and other measures required to prevent sedimentation or other contamination of water draining from the site as a result of construction activities and this project.
- j. Miscellaneous – All items which are shown on the plans or identified in the specification or implied thereby, or incidental to any of the described items, even though not specifically called out in a particular item shall be included as part of this bid item.

2. Measurement

Measurement for Bid Item **No. 9** “Demobilization” will be based upon completion of such work as a lump sum. The measurement shall be made by the contractor and verified by the Owner’s representative.

3. Payment

Payment for Bid Item **No. 9** “Demobilization” shall be made in a lump sum amount for this item. **No payment shall be made until full completion of the Work within the bid item.** The lump sum cost shall constitute full compensation for furnishing all planning, acquisition, labor, materials, tools, and equipment associated with performing all Work involved in demobilizing, stabilizing and returning the site in a fully operable condition.

J. New Cathodic Protection System

1. Description

This Work includes the furnishing of all tools, equipment, labor and materials required to accomplish all of the following Work within the limits designated on the plans or as directed by the Engineer in accordance with the plans and specification. The Work includes but is not limited to the following:

- a. Impressed current cathodic protection system conforming to AWWA D104
- b. System design as appropriate to the Contractor designed roof and existing tank and pursuant to these specifications.
- c. System to match system on the adjacent tank MG#1 to the extent appropriate.
- d. 6 MMO Titanium anode assemblies
- e. Tank mounted IRT C.P. Sentinel Aqua-Line Cathodic Protection Rectifier
- f. Channel type EPDM grommets at hand holes
- g. Stainless steel handhole covers
- h. Component installation, connection and preliminary set up and testing.
- i. System activation and adjustment after the warranty period.

2. Measurement

Measurement for Bid Item “Cathodic Protection System” Work will be based upon completion of this work as a lump sum. The measurement shall be made by the contractor and verified by the Owner’s representative.

3. Payment

Payment for Bid Item “Cathodic Protection System” shall be made on a percent complete basis based on the lump sum amount for this item. The lump sum cost shall constitute full compensation for furnishing all planning, acquisition, labor, materials, tools, and equipment associated with performing all Work involved in providing the cathodic protection system in place, operational, and in conformance with the plans & specifications.

END OF SECTION

Section 09905

PROTECTIVE COATINGS

PART 1 - GENERAL

1.01 SCOPE SUMMARY

- A. The work described in this section covers protective coatings for the project including the interior and exterior surfaces of one existing water tank, accessible portions of piping, appurtenances and of new upgrade appurtenances and areas damaged by welding or other actions associated with this project. The project goals are to achieve coating systems that provide long term service, good aesthetics and low maintenance cost using best safety and environmental practices.
- B. Removal and containment and handling of existing lead-based coatings is part of the Work.
- C. The contractor shall supply all coatings, solvents, abrasives, air compressors, hoses, paint guns, materials storage and any other tools, equipment and consumables necessary for the proper preparation and application of the coatings.
- D. The Contractor shall be familiar with the service conditions of the tank and shall submit preparation and coating applications as appropriate. The Contractor shall consult the Engineer prior to any coating activity where the coating of certain components or surfaces is in question.

1.02 RELATED WORK SPECIFIED ELSEWHERE

- A. Section 01100, Scope and Control of the Work
- B. Section 13010, Upgrades of Existing Tanks
- C. Section 13020, Replace Water Tank Roof

1.03 REFERENCES

- A. Without limiting the general aspects or other requirements of this specification, work and equipment shall conform to applicable requirements of County, State and Federal codes, laws and ordinances governing the work, American Water Works Association, SSPC: The Society of Protective Coatings, and the manufacturer's printed instructions.
- B. When conflict exists between any of the referenced codes, laws, ordinances, specifications and standards contained herein, the most conservative relative to the project goal of system longevity shall govern.
- C. The latest edition of the following standards and regulations form a part of this specification. Materials, preparation, application, repair methods, and all other aspects of the work and inspections shall conform to following codes and standards:
 - 1. AMERICAN SOCIETY FOR TESTING AND MATERIALS (ASTM)

- a. ASTM D1186, Standard Test Method for Nondestructive Measurement of Dry Film Thickness of Nonmagnetic Coatings Applied to a Ferrous Base
 - b. ASTM D3359, Standard Test Method for Measuring Adhesion by Tape Test
 - c. ASTM D4138, Standard Practices for Measurement of Dry Film Thickness of Protective Coating Systems by Destructive, Cross-Sectioning Means
 - d. ASTM D4285, Standard Test Method for Indicating Oil or Water in Compressed Air
 - e. ASTM D4414, Standard Practice for Measurement of Wet Film Thickness by Notch Gages
 - f. ASTM D4417, Standard Test Methods for Field Measurement of Surface Profile of Blast Cleaned Steel
 - g. ASTM D5402, Standard Test Methods for Assessing the Solvent Resistance of Organic Coatings Using Solvent Rubs
2. AMERICAN WATER WORKS ASSOCIATION (AWWA)
- a. AWWA D102-14, AWWA Standard for Coating Steel Water-Storage Tanks
 - b. AWWA M42, AWWA Manual of Water Supply Practices, Steel Water Storage Tanks
 - c. AWWA C652-02, AWWA Disinfection of Water-Storage Facilities
3. SOCIETY OF PROTECTIVE COATINGS (SSPC)
- a. SSPC-PA 1, Shop, Field, and Maintenance Painting of Steel
 - b. SSPC-PA 2, Measurement of Dry Coating Thickness with Magnetic Gages
 - c. SSPC-VIS 1, Visual Standard for Abrasive Blast Cleaned Steel
 - d. SSPC-VIS 3, Visual Standard for Hand and Power Tool Cleaned Steel
 - e. SSPC Publication No. 91-12, Coating and Lining Inspection Manual
 - f. SSPC Visual Comparison Manual
 - g. SSPC-SP 1, Solvent Cleaning
 - h. SSPC-SP 3, Power Tool Cleaning
 - i. SSPC-SP 7, Brush-off Blast Cleaning
 - j. SSPC-SP 10, Near-White Metal Blast Cleaning
 - k. SSPC-SP 11, Power Tool Cleaning to Bare Metal
 - l. SSPC-SP 12, Surface Preparation and Cleaning of Metals

4. NACE INTERNATIONAL (NACE)
 - a. NACE SP0188-2006, Standard Recommended Practice for Discontinuity (Holiday) Testing of Protective Coatings
 - b. NACE RP 0178-89, Standard Recommended Practice for Fabrication Details, Surface Finish Requirements, and Proper Design Considerations for Tanks and Vessels to be Lined for Immersion Service.
- D. NATIONAL SANITATION FOUNDATION (NSF)
 1. NSF 61, Drinking Water System Components - Health Effects
- E. EQUIPMENT AND COATING MANUFACTURER'S PUBLISHED INSTRUCTIONS

1.04 SUBMITTALS

- A. Submittals shall be provided in accordance with these special provisions. **The Contractor shall provide submittals before the pre-job conference.** No work shall be done on items needing submittal approval until the material or plan is approved by the Owner.
- B. Required Submittals. Submittals shall be furnished by the contractor as called for in the various sections of these Special Provisions and for following items as a minimum:
 1. Coatings/Color (each coat)
 2. Solvents/Thinners
 3. Abrasives
 4. Magnetic Dry Film Thickness Gage
 5. Coating Conditions Verification Equipment (Temperatures/Humidity)
 6. Daily Report Form
 7. Caulking (See Coating Systems)
- C. Product Submittals. Approval of materials and products by the Owner does not waive the Contractor's responsibility to provide a material which will meet the project goals.
- D. Coating Submittals. The submittals for coating products shall, at a minimum, contain the following information:
 1. Material Name / Manufacturer
 2. Standards of which the product complies
 3. Conditions for which the product was developed or can be used
 4. Application guidelines including manufacturer approved field repair method of shop applied primers
 5. Testing information / data on product

6. Any material guarantees
7. Expected life
8. Surface Preparation for coatings including any special requirements for this project
9. Recommended uses
10. Safety precautions - and MSDS sheets
11. Name and phone number of the area sales representative for the product
12. Any other information the contractor feels would be helpful in the Owner's review

1.05 OSHA COMPLIANCE.

- A. Contractor shall comply with all applicable regulations including state and federal OSHA and these Special Provisions.
- B. Contractor is responsible for complying with Cal/OSHA regulations for lead in construction in accordance with California Code of Regulations, California Title 8, Section 1532.1. Lead. Some levels of lead are undoubtedly present and Cal/OSHA requires compliance with 1532.1 if the paint contains lead at any level.
- C. The costs for complying with all OSHA requirements shall be considered as included in the various contract prices paid and no additional compensation will be allowed. Contractors are welcome to take lead samples in advance by arrangement with the owner.

PART 2 - PRODUCTS

2.01 ABRASIVES

- A. Abrasive used in blast cleaning operations shall be recyclable fused copper slag. Abrasives shall meet all requirements of the California Air Resources Board for content and emissions.
- B. Abrasives shall be certified for unconfined dry blasting pursuant to the California Administrative Code, Section 92520 of Subchapter 6, title 17, and shall appear on the current listing of approved abrasives.

2.02 CAULKING

- A. The caulking sealant shall be a premium-grade, high-performance, moisture-cured, 1-component, polyurethane-based, non-sag elastomeric sealant that meets ASTM C-920, Type S, Grade NS, Class 25 such as Sika 1a or equivalent. The material shall be capable of $\pm 25\%$ joint movement and withstand submerged conditions. The material shall have excellent resistance to aging, weathering and maintain elasticity during long term exposure in the given conditions.

2.03 COATING MATERIALS.

- A. Coating materials shall conform to the following requirements:

1. Only high-grade products of manufacturers having an established good reputation in the manufacture of quality protective coatings shall be used. All coatings on the interior surfaces of the tank or other areas that can contain potable water shall conform to NSF-61(including NSF-600).
2. Coating materials shall be brought to the job site in the original sealed containers. Materials found to be damaged or out of date shall be removed from the site. Materials shall be stored in an enclosed structure out of the weather protecting them from excessive heat or cold.
3. The Contractor may submit paint materials of manufacturer's other than those specified herein in accordance with these Special Provisions. The Contractor shall provide satisfactory documentation from the firm manufacturing the proposed material that the material meets the specified requirements and is equivalent to or better than the listed materials in the following properties:
 - a. Quality
 - b. Durability
 - c. Resistance to abrasion and physical damage
 - d. Life expectancy
 - e. Ability to recoat in future
 - f. Solids content by volume
 - g. Dry film thickness per coat
 - h. Compatibility with other coatings
 - i. Suitability for the intended service
 - j. Resistance to chemical attack
 - k. Temperature limitations in service and during application
 - l. Type and quality of recommended undercoats and topcoats
 - m. Ease of application
 - n. Ease of repairing damaged areas
 - o. Stability of color

PART 3 - EXECUTION

3.01 HOUSEKEEPING AND CLEANUP

- A. At the end of each work day, dust, paint chips and abrasive shall be removed from the surfaces and surrounding areas. Spent abrasive shall be stored in temporary storage containers on site pursuant to Best Management Practices and Best Pollution Prevention Practices listed under federal and state guidelines.

- B. As work proceeds, promptly remove all coating that is spilled, splashed, or splattered. Collect empty containers, rags, waste material, and debris and store or remove from the site as appropriate.
- C. The site shall be maintained free of unnecessary accumulations of tools, equipment, surplus materials, and debris. Equipment maintenance and spill prevention procedures shall be adequate to prevent spills and leaks.
- D. Upon completion of the work, the Contractor shall remove all excess materials, equipment, containers, and waste from the job site. Coating spots or stains shall be removed from adjacent surfaces and surfaces repaired if needed.

3.02 PROTECTION OF PROPERTY

- A. Blast residue and overspray shall be contained pursuant to the **Containment Requirements** of these specifications.
- B. The Contractor shall be attentive to wind conditions to prevent the drifting of abrasive blast residue and overspray and shall make every effort to prevent the damage of public and private property. Weather conditions shall dictate the application of coatings and, if necessary, adjustments in the contract working days will be made in accordance with the provisions of the Standard Specifications. If overspray or other damage occurs, the contractor shall incur all expenses for the clean-up or repair of the damages public and/or private property.
- C. The Contractor shall protect the following surfaces from abrasive blasting, entry of sand, grit, dust and paint or other damage by wrapping, masking or other methods:
 - 1. PVC piping including high inlet on tank interior
 - 2. Sheet metal siding
 - 3. Any pump/motors
 - 4. Threaded portions of valve and gate stems
 - 5. Machined surfaces for sliding contact, bearings, sprockets or gears
 - 6. Surfaces to be assembled against gaskets
 - 7. Mechanical drives
 - 8. Stainless steel or aluminum surfaces not specifically designated for coating or painting
 - 9. Coated or plated items (including galvanized) not scheduled for painting or coating
 - 10. Drains & relief valves
 - 11. Concrete surfaces
 - 12. All other surfaces not specifically designated for coating or painting.

- D. The Contractor shall contact operations personnel for verification of adequate protection of critical items such as mechanical items.
- E. If required to prevent damage, protective coverings or drop cloths shall be used to protect floors, fixtures and equipment. The Contractor shall mask, cover and shield all gauges, instruments, stainless steel, aluminum, galvanized steel, glass, plastic, equipment and all other surfaces not intended for coating as specified. Surfaces, from which inadvertently applied materials cannot be removed satisfactorily, shall be recoated or repainted to produce a finish satisfactory to the Owner.
- F. Coating application to exterior surfaces shall be completed using roller and brush methods. Spray application is not allowed. The Contractor shall prevent coating material to spatter, spray or otherwise transfer beyond 35' from the tank.

3.03 CONTAINMENT REQUIREMENTS

- A. The containment system shall comply with SSPC Guide 6 for Dry Abrasive Blast Cleaning - Full Containment with Negative Pressure (SSPC Class 1A)
 - 1. The enclosure shall be designed, installed, and maintained to sustain maximum anticipated wind forces, including negative pressure. Flapping edges of containment materials are prohibited and the integrity of all containment materials, seams, and seals shall be maintained for the duration of the project. Airflow inside containment shall be designed to provide visibility and reduce worker exposures to toxic metals according to OSHA regulations. The blast enclosure shall have an airlock or resealable door entryway to allow entrance and exit from the enclosure without allowing the escape of blasting residue.
 - 2. Appropriate filtration shall be used on the exhaust air of dust collection and abrasive recycling equipment as required to comply with applicable regulations. The equipment shall be cleaned/maintained, enclosed, or replaced if visible dust and debris are being emitted and/or the regulated area or high-volume monitor lead levels are not in compliance.
- B. Provide and maintain containment system surrounding the work for the purpose of controlling emissions of dust and debris according to the requirements of this specification. Working platforms and containment materials that are used shall be firm and stable and platforms shall be designed to support the workers, inspectors, spent surface preparation media (e.g., abrasives), and equipment during all phases of surface preparation and painting. Platforms, cables, and other supporting structures shall be designed according to OSHA regulations. If the containment needs to be attached to the structure, the containment shall be attached by clamping, or similar means. Welding or drilling into the tank structure is prohibited.
- C. Monitor weather and wind conditions at all times. The containment shall be dropped in the event of sustained winds of 40 mph (64 kph) or greater and all materials and equipment secured.
- D. The containment system shall maintain the work area free of visible emissions of dust and debris, with no debris permitted outside of the containment area at any time.

- E. The containment materials shall be cleaned of loose material prior to relocation or dismantling. Acceptable methods of cleaning include blowing down the surfaces with compressed air while the ventilation system is in operation, HEPA vacuuming, and/or wet wiping. If paint chips or dust is observed escaping from the containment materials during moving, all associated operations shall be halted and the materials and components recleaned.

3.04 SURFACE PREPARATION

- A. The Contractor shall complete low-pressure water cleaning of surfaces prior to other applicable surface preparations. Surfaces shall be cleaned in accordance with SSPC-SP12 LP WC. All oil, grease, salts, rust, loose materials or other contaminants that will adversely impact adhesion or cause coating failure shall be removed.
- B. Surface preparation shall be provided as detailed for the specific aspects of the work. Surface preparation shall conform to this specification and the applicable material manufacturer's recommendations. The contractor shall provide all necessary testing and **recycle the abrasive** through an approved recycling program. The Contractor shall provide documentation of receipt of the material by the recycler.
- C. All welding shall be completed prior to surface preparation and coating. Do not apply any part of a coating system before the Owner's Quality Assurance has reviewed the surface preparation. Coating applied without inspection shall be removed by abrasive blasting and reapplied in accordance with this specification.

3.05 APPLICATION.

- A. Coating application on exterior surfaces may be completed using roller and brush methods or spray methods.
- B. Coatings applied to materials prior to forming (i.e., roof panels) shall be removed at least 5 inches away from any bends by abrasive blasting to a commercial blast. Edges shall be feathered.
- C. Thinning shall be permitted as recommended by the manufacturer for the conditions of application and allowed by applicable regulations.
- D. Each application of coating or paint shall be applied evenly, free of sags and runs, with no evidence of poor workmanship. Care shall be exercised to avoid lapping on glass or hardware. Coating and paint shall be sharply cut to lines. Finished surfaces shall be free from defects or blemishes.
- E. When two or more coats of coating or paint are specified, each coat shall be adequately contrasting in color to act as an indicator of coverage.
- F. All material shall be applied in accordance with the manufacturer's recommendations and these specifications. Maximum permissible level of soluble salts or chemicals shall be as recommended by the coating manufacturer and verification shall be the responsibility of the contractor.
- G. At least one brush stripe coat shall be applied, on the interior, to edges, corners, and irregular surfaces such as welds and fasteners. Minimum recoat times shall be observed

between the stripe coat and the next coat. The stripe coat may be applied after the prime coat if appropriate.

- H. Where the number of coats or dry film thickness is specified, they shall be considered a minimum. The Contractor shall apply additional coats as necessary to achieve the specified dry film thickness.
- I. Coating procedures and recoat cycles are critical. It is imperative that the manufacturer's recommendations be strictly followed. Any deviation from printed literature must be approved in writing by the manufacturer's technical department and the owner prior to starting alternate procedures.

3.06 CONTRACTOR QUALITY CONTROL.

- A. The Contractor is responsible for quality control. The Contractor shall provide adequate equipment to monitor project quality. The Contractor shall document conditions, progress, project personnel and equipment on site, in a daily report. Environmental readings shall be recorded at the beginning and end of each painting sessions. Signed daily reports shall be provided to the Owner Representative on a weekly basis.
- B. No coating or paint shall be applied to wet or damp surfaces, in rain, snow, fog, or mist, when the steel temperature or surrounding air temperature is less than 5 degrees Fahrenheit (5°F) above the dew point, nor in conditions not recommended by the manufacturer. If unacceptable weather conditions are prevalent, coating or painting shall be delayed or postponed until conditions are favorable. The day's coating or painting shall be completed in time to permit the film sufficient drying time prior to damage by atmospheric conditions.
- C. The thickness of coatings shall be checked with a non-destructive, magnetic type thickness gauge. Coating thickness measurement procedures shall be pursuant to SSPC-PA-2. Additional measurements may be made when determined by the inspector to be in the best interest of the project. In cases of dispute concerning film thickness, measurements made with instruments shown to be in calibration with the National Bureau of Standards calibration plates shall predominate. The contractor shall furnish U.S. Department of Commerce, National Bureau of Standards certified thickness calibration plates to test accuracy of dry-film thickness gauge. All inspection devices shall be in good working order.

Dry film thickness that exceeds the coating manufacturer's recommendation is unacceptable and shall be removed by the Contractor at no extra cost to the Owner.

- D. The coating integrity of all interior coated metallic surfaces shall be tested with an approved wet sponge electronic holiday detection device. A non-sudsing type wetting agent such as Kodak Photo-Flo, shall be added to the water prior to wetting the detector sponge. Non-submersed roof and shell areas shall be included in the holiday testing. Holiday detection of interfaces between roof plate and rafters which are not seal welded is not required.

The contractor shall provide holiday detection devices in good working order. Acceptable devices include, but are not limited to, K-D "Bird Dog" non-destructive holiday detector and Tinker-Razor Model M-1 for coating to 20 mils dry film thickness.

All holiday detection devices shall be operated in the presence of a representative of the Owner. Testing shall be conducted pursuant the coating manufacturer's recommendations and NACE RP 0188 (latest edition). All rejected areas shall be marked and repaired in accordance with the manufacturer's printed recommendations and re-tested. No pinholes or other irregularities will be permitted in the final coating.

3.07 QUALITY ASSURANCE.

- A. The Owner may provide shop or field inspection of the work. The Contractor shall provide the Owner's Representative with a 3 day notice prior to any surface preparation or coating application. All work shall be performed with the presence of the Owner's Representative unless written prior approval has been granted. Coatings applied without inspection shall be removed by abrasive blasting and reapplied in accordance with this specification.

3.08 COATING SYSTEM – EXTERIOR SURFACES

- A. All exterior surfaces shall be coated unless noted herein. Ladder safety climb rails, level gage board, vent screens and other "bolt on" hardware shall be removed during coating and replaced after completion.
- B. Included Items: All exterior surfaces including, but not limited to, existing tank, new roof, new appurtenances and piping.
- C. Surface Preparation: Abrasive blast per SSPC-SP6 Commercial Blast Cleaning and the coating manufacturer's recommendations. Coatings applied to materials prior to forming (i.e., roof panels) shall be removed at least 5 inches away from any bends by abrasive blasting to a commercial blast. Edges shall be feathered.
- D. Exterior Coating System (AWWA D-102 Outside Coating System No. 5). Epoxy prime coat with an epoxy intermediate coat followed by aliphatic polyurethane. Examples of approved coatings are as follows:
 - 1. Devoe
 - a. Primer: Devoe High Performance Coatings Bar-Rust 231 Multi-Purpose Epoxy Mastic, 3 - 5 mils
 - b. Intermediate: Devoe High Performance Coatings Bar-Rust 231 Multi-Purpose Epoxy Mastic, 3 - 5 mils
 - c. Finish: Devoe High Performance Coatings Devthane 378H Aliphatic Urethane Semi-Gloss, 2 - 3 milsor
 - 2. Carboline
 - a. Primer: Carboguard 893 @ 3-5 mils DFT
 - b. Intermediate: Carboguard 893 @ 3-5 mils DFT
 - c. Finish: Carbothane 134VOC @ 2-3 mils DFT

or

3. Tnemec

- a. Primer: Tnemec L69 Epoxoline or V140F Pota-Pox, 3 - 5 mils
- b. Intermediate: Tnemec L69 Epoxoline or V140F Pota-Pox, 3 - 5 mils
- c. Finish: Tnemec 1075 Endura-Shield, 2 - 3 mils

or

4. Approved equal.

- E. Color: Match tank #1: SW 4023 – “Olivine” from the Sherwin Williams Protective and Marine Coating Color System 4000 Series color chart. Submit color for Owner approval.

3.09 COATING SYSTEM – INTERIOR SURFACES

- A. Included items: All Interior surfaces.

- B. Surface Preparation: Abrasive blast per SSPC-SP10 Near White Blast Cleaning and the coating manufacturer’s recommendations.

- C. Interior Coating System (AWWA D-102 Inside Coating System No. 2): Three coat, two component epoxy coating system. A prime, intermediate and finish coat of two component epoxy. An example of approved coatings is as follows:

1. Tnemec

- a. Primer: Tnemec L140 Pota-Pox, 3 mils
- b. Intermediate: Tnemec L140 Pota-Pox, 4 mils
- c. Finish: Tnemec L140 Pota-Pox, 5 mils

or

2. Sherwin Williams

- a. Primer: SherPlate 600 @ 3 mils DFT
- b. Intermediate: SherPlate 600 @ 4 mils DFT
- c. Finish: SherPlate 600 @ 5 mils DFT

or

3. Approved equal.

- D. Color: Tank white

3.010 CURING AND VENTILATION

- A. Forced ventilation of the tank interior shall be conducted for a period equal or exceeding the coating manufacturer's recommended minimum recoat time for each coat and for at least 48 hours after the final coat. The ventilation shall be equal to or greater than specified in AWWA D102-14. Circulation through low areas of the tank, piping and other associated areas that will hold solvent vapors shall be assured.
 - B. If heating or dehumidification are required for proper curing, the Contractor shall provide these as a part of the Base Bid and at no additional cost to the Owner.
- 3.011 CAULKING
- A. Caulk shall be applied to unsealed joints such as bolts, nuts, bolted flanges etc. to prevent moisture intrusion and rust staining ("bleeding"). Minimum recoat times for caulking shall be followed. Caulk shall be applied only to clean dry areas that are free of loose materials and dust. Follow manufacturer's installation instructions. Caulk shall be applied between the prime and finish coats.
- 3.012 LABELING
- A. Label inside of roof hatch "FALL HAZARD PROTECT OPENING OR MONITOR WHEN OPEN – CONFINED SPACE ENTRY BY PERMIT ONLY". Labeling shall be located on the inside of the hatch lid. The labeling shall be done with red or black colored NSF 61 approved epoxy. Letters shall be neatly stenciled and shall be 2" tall or larger.
- 3.013 CERTIFICATE OF COMPLIANCE
- A. The Contractor shall provide a Certificate of Compliance stating that "The Coating Work has been completed in conformance with the Specifications and Curing has been completed and confirmed pursuant to the Project Specifications and the coating manufacturer's recommendations and the tank is ready to be filled." The Certificate of Compliance shall be provided to the Owner and Engineer prior to disinfection.
- 3.014 TANK DISINFECTION.
- A. After cure of the completed interior coating has been completed, the interior of the tank shall be thoroughly cleaned and disinfected. All work shall conform to the requirements of ANSI/AWWA C652, Standard for Disinfection of Water-Storage Facilities, Method 2. The Contractor shall test the disinfection solution for chlorine concentration during the observation of the Owner Representative and prior to start of disinfection. Upon completion of disinfection, the Owner's representative shall photograph the tank interior and the Contractor shall seal the tank.
- 3.015 SOAK TEST AND MONITORING
- A. The Owner will fill the tank and complete the five day soak test and VOC monitoring including organics listed on the coating manufacturer's MSDS. The reservoir must also be sampled for coliforms and have satisfactory results. The Owner shall submit the results of all monitoring and testing to the State Water Resources Control Board and receive approval prior to putting the reservoir into service.
- 3.016 WARRANTY INSPECTION.

- A. The Owner shall provide for inspection of any or all of the work completed under this contract. The date and method of the inspection shall be established and notification given at least 30 days in advance. If an inspection date has not been established within 13 months after completion of the coating work, the first anniversary inspection shall be considered waived. Waiver of the warranty inspection will not relieve the Contractor of the responsibility to repair defective work.

3.017 WARRANTY REPAIR.

- A. If any work is found to be defective, as determined by the Owner, its employees or consultants, the Contractor shall promptly correct the defective work with no cost to the Owner.
- B. The surfaces shall be prepared and re-coated as per the applicable original coating system. Preparation and application procedures for coating repairs shall conform to manufacturer's recommendations and be approved by the Owner with the intent of bringing the defective areas up to the quality level of the original work required by this specification.
- C. The Owner may require delay of repair where necessary for efficient operation of the water treatment facility. If the Contractor does not complete corrective work promptly, the Owner may complete the work itself or hire others to complete it. The original Contractor and its Surety will be liable to the Owner for all direct and indirect costs.
- D. The cathodic protection system shall be energized and adjusted after completion of the warranty period and repair work if applicable.

END OF SECTION

Section 13010

UPGRADES TO THE EXISTING TANK

PART 1 - GENERAL

1.01 SUMMARY

The intent of the work described in this section is to upgrade appurtenances to provide a safe workplace and assure compliance with applicable OSHA regulations for 1 existing steel tank.

1.02 SCOPE

- A. Design, fabricate, install, and coat upgrades on 1 existing tank in order to provide a safe workplace and assure compliance with applicable OSHA regulations. The Contractor's work will include engineering by the Contractor's Engineer for all work.
- B. Provide removal of lead containing and lead based coatings pursuant to all applicable regulations prior to any work. Coating removal shall be completed in a manner that contains all dust and protects contractor personnel and the public.
- C. Demolish, remove and recycle the applicable existing components that are being replaced or upgraded.
- D. The intent is to upgrade the exterior ladder, ladder door, and guardrail of the tank to current OSHA Standards and these special provisions. The specific accessories required for each tank are listed below. The dimensions provided herein are intended to be general information. The Contractor shall field verify all dimensions prior to fabrication.
- E. The Contractor shall design, fabricate, and erect all aspects of the repairs pursuant to AWWA D100-31 (including Section 13 for seismic design), CBC 2019, California Department of Public Health Drinking Water Statutes, and all other applicable rules and regulations. NSF/ANSI 61, Standard for Drinking Water System Components shall apply. All contractor design calculations and drawings shall be stamped by a Registered Professional Civil or Structural Engineer with design experience on over 50 similar welded steel tanks.

1.03 EXISTING CONDITIONS

- A. Million Gallon Tank #2
 - 1. See appendix C for Inspection Report for the Million Gallon Tank #2 (MG#2)
 - 2. Lead based coatings are present on the exterior of this tank. See appendix A for lead and other heavy metals analysis.
 - 3. Tank type: ground-supported, welded steel
 - 4. Erected: 1976

5. Tank diameter: 66'-0" (to be verified by contactor)
6. Tank shell height: 40'-0" (to be verified by contactor)

1.04 RELATED WORK SPECIFIED ELSEWHERE

- A. Section 01100, Scope and Control of the Work
- B. Section 09905, Protective Coatings
- C. Section 13020, Replace Water Tank Roof

1.05 REFERENCES

The latest edition of standards and regulations herein form a part of this specification. Design details, repair methods, fabrication, erection, and all other aspects of the work and inspections shall conform to following Codes and Standards:

- A. AMERICAN WATER WORKS ASSOCIATION (AWWA)
 1. AWWA D100-21, AWWA Standard- Welded Carbon Steel Tanks for Water Storage
- B. CALIFORNIA BUILDING STANDARDS COMMISSION (CBSC)
 1. CBC 2019, California Building Code
- C. NATIONAL ASSOCIATION OF CORROSION ENGINEERS (NACE)
 1. NACE SP0178-2007, Design, Fabrication, and Surface Finish Practices for Tanks and Vessels to Be Lined for Immersion Service.
- D. AMERICAN SOCIETY OF CIVIL ENGINEERS (ASCE)
 1. ASCE/SEI 7, Minimum Design Loads For Buildings and Other Structures
- E. NATIONAL SANITATION FOUNDATION (NSF)
 1. NSF 61, Drinking Water System Components - Health Effects.
- F. AMERICAN PETROLEUM INSTITUTE (API)
 1. API 653, Tank Inspection, Repair, Alteration and Reconstruction, API Standard 653-Latest

1.06 SUBMITTALS

Engineering calculations shall be provided to show the adequacy of structural items where loads are specified by applicable industry standards. The design calculations and detailed drawings shall be signed by a Civil or Structural Engineer licensed to practice in the state of California.

- A. Tank roof structure and accessory drawings and supplemental information will include the following:

1. Dimensional drawings indicating size and thickness of all members
 2. Attachment details
 3. List of appurtenances
 4. Fabrication details
 5. All details of welded joints. Weld joint details shall include, size, joint preparation, identification of field welds, and indication of welds requiring low hydrogen procedures.
- B. Welding Procedures
- C. Welder Certifications
- D. Mill Test Reports

PART 2 - PRODUCTS

2.01 PLATE AND SHEET

- A. Plate and sheet materials shall conform to the design requirements of AWWA D100.

2.02 COATINGS

- A. All new accessories shall be coated pursuant to these special provisions.
- B. Spot repair coatings damaged as part of this work pursuant to these special provisions. Prepare and coat locations with damage associated with this work pursuant to the exterior coatings section of these special provisions. Power tool cleaning will be an acceptable alternative to blast cleaning.

2.03 TANK ACCESSORIES

A. **OUTSIDE LADDER (LOWER SECTION) AND CAGE**

The new lower ladder section shall substantially match the existing upper section and shall extend from the existing mid-platform (with a minimum of 4'-0" extension above the top of the platform deck) to within 1'-0" above the foundation or landing. The new lower ladder section and cage shall be attached and supported by connection to the tank shell. Round bar "rung extensions" shall extend between the upper and lower ladder stringers adjacent to rungs located 3' and 4' above the top of the mid platform.

The ladder shall be coated with specified exterior coating system. The Contractor shall notify the Owner's Representative for final inspection.

B. **ROOF GUARDRAIL**

Roof guardrails shall be provided at the existing exterior ladder similar to the configuration on MG#1 as shown in Appendix D. Size of posts and rails and the height of the guardrail assemblies shall comply with applicable state and federal regulations and AWWA D100.

Guardrails shall be steel with a top rail, mid rail(s), and vertical posts. Spacing between vertical posts shall match existing and shall be spaced a maximum of 7'-0" apart. Guardrail shall include a 4" x 1/4" toe board. The toe boards shall be provided with bolted attachment to allow removal for painting and maintenance. The Contractor shall notify the Owner's Representative for final inspection.

"Alleyway" railing sections are designed to prevent falls through unprotected openings at the outside ladders. The alleyway railing shall extend a minimum of 4'-0" inboard from the existing railing nearest the outside ladder. The inboard end of the alleyway shall be protected with a self-closing gate (Fabenco XL71-36 or equal) that is permanently attached to the post on one side such that it opens toward the tank center. The gate shall be hot dip galvanized.

Provide welded attachment between the new guardrail sections and the existing ladder cage or guardrail at locations opposite of the top and intermediate rails. Attachment may be made with flat bar (1/4" x 2" minimum) where appropriate.

C. PERSONNEL FALL PROTECTION SYSTEM

Provide a personnel fall protection system for protection of personnel working on the roof. The new roof guardrail will not be adequate protection for accessing all areas of the roof. The Contractor provided system shall include two stainless steel pivoting "D-ring" anchors near the roof vent which will be used as anchors for fall protection of personnel accessing various unprotected areas of the roof. Use swivel anchors (Miller# 365-RACSW100S-316) or equal. Anchor points shall be designed for loading in any direction on the roof without bolting to the roof. The anchors will be installed at a location specified by the Owner's Representative. Two cable systems shall be included. The cables will be permanently attached to the anchors. The cables shall extend radially to within three feet of the nearest roof edge. The D-rings and cable systems shall be designed as fall protection systems per OSHA regulations and 5,000 lb. minimum, whichever is greater. The Contractor shall provide a design drawing for the system that is stamped by an engineer experienced in the design of fall protection systems. Compression sleeves used in the system shall be stainless steel. Cables shall be nylon-coated wire rope of AISI Grade 304 stainless steel.

D. HORIZONTAL SWINGING LADDER DOOR FOR CAGED LADDERS

Where specified, provide an anti-climb door for a caged ladder. The door shall fit beneath the ladder cage and shall incorporate a top closure plate which prevents access to the lower section of the ladder. The door shall be capable of being secured with a conventional padlock. The door shall be designed to be latched in the open position to permit safe access to the ladder. Minimum plate thickness shall be 3/16". The horizontal cage cover portion shall be designed for the specified snow load.

E. LEVEL INDICATOR

The Contractor shall provide a target type liquid level indicator. The indicator board shall be a one-piece extruded 6" aluminum channel. A bolt together board will not be acceptable. The indicator tape shall be pre-printed solid vinyl. Painted markings are not acceptable. The level pointer "target" shall be made from 3/16" galvanized steel. The target shall be balanced to eliminate binding during target movement. The internal hollow

float shall be made of heavy gauge stainless steel. All parts, including cable conduits, tensioners, and bottom anchors, shall be made of corrosion resistant materials. The level gage shall be full length.

F. LADDER SAFETY SYSTEM

Galvanized steel ladder safety devices shall be provided for the outside ladder (upper and lower sections). The ladder safety devices shall be compatible with the Owner's other ladder climbing systems which are Miller, North Safety Product Saf-T-Climb systems. The ladder safety systems shall include harness and shuttle designed for the system.

G. SQUARE ROOF HATCH

Provide a 39" square hinged roof hatch to comply with requirements of OSHA and AWWA D100 for fixed ladders. Stainless steel hinges and latches are required to protect inaccessible wear points. No existing internal ladder is present.

H. ROOF VENT

Provide a mushroom style roof vent that is designed for optimum venting performance and long-term corrosion protection. The vent openings shall be concealed under the lid to reduce the number of air-borne particles allowed to enter the tank. The venting area shall be covered with an 8-mesh bronze insect screen. The vent cover shall be hinged and lockable to allow ease of opening for inspection and to help prevent unauthorized removal. The vent cover shall be made of fiberglass to allow installation and removal by one person. To deter subversive damage, the screen clamping system is only accessible with the vent lid removed. With the lid off, the 37-inch diameter vent shall readily accept installation of common industrial fans for forced ventilation. All brackets, connection points, wear points and fasteners, shall be AISI 316 stainless steel. Vent height shall be appropriate for snow depth (4'-0" minimum to bottom of cover) and shall be equipped with pressure/vacuum relief mechanism.

I. WELDED PATCHES

Patch plate material shall be ASTM A36. Patches shall be 1/4" thick and dimensioned as required to achieve a minimum 1/2" lap to cover shell vents. Patch plates will be as large as 2 sq. ft. or as required to cover shell vents.

J. MID PLATFORM GRATING

Provide new (replacement) grating on the existing exterior ladder platform. Grating shall be hot dip galvanized steel, 1 1/2" x 3/16" bearing bar, serrated McNichols #GW-150 (match grating on MG#1). Grating shall be attached using McNichols type CB clips (minimum of 4).

PART 3 - EXECUTION

3.01 GENERAL FABRICATION AND WELDING

- A. All corners and edges that are exposed upon completion of fabrication shall be finished to a minimum radius of 1/16" to optimize coating application. Finishing with grinding wheels may produce "hard" corners which are not acceptable. Grinders equipped with "soft pads" or sanding discs on rubber backing are often necessary to produce acceptable finishes without corners and edges.

3.02 WELD PROFILES AND FINISHING

- A. All weld spatter shall be removed prior to coating. Abrasive blasting is not reliable for removal of all weld spatter, so all weld spatter shall be removed as part of tank erection and prior to the start of abrasive blasting.
- B. Removal of Temporary Attachments and Existing Ladder Attachment Clips
 - 1. All temporary and unnecessary brackets, lugs, and clips (such as those used during erection including attachment points from previously removed interior ladder) shall be removed from the tank. Pits created during removal shall be repaired with consideration of minimum weld length and accepted welding procedures. Welded repairs shall be ground flush. Removal of temporary attachments shall be by grinding followed by sanding to smooth course grinding marks (deeper than 4 mils as measured with profile tape) and radius any angular transitions.

3.03 QUALITY

- A. Shop and field welding quality control shall be the responsibility of the Contractor. Weld quality assurance inspection will be provided by the Owner's Representative. Safe access and lighting are an important aspect of producing a quality product for both the contractor personnel and quality assurance personnel. Safe access, lighting, and assistance shall be provided by the Contractor for the Owner's Representative(s) using the Contractor's rigging and equipment to allow inspection or observation of all work. This shall be provided by the Contractor at no additional cost.
- B. The intent of nondestructive testing on this project is to confirm that welds meet the specified minimum requirements. Testing will be done by sampling welds of the most questionable quality, those under higher stress, or by random selection.

3.04 MILLION GALLON TANK #2

- A. Install the new lower section of exterior ladder between the existing mid platform and the existing grade.
- B. Verify dimensions of the existing mid platform. Cut and fit new grating to fit.
- C. Fabricate and install new guardrail to conform to OSHA requirements. Roof layout shall be similar to the adjacent tank MG#1 as shown in Appendix D and based on the existing location of the outside ladder. The new guardrail shall extend a minimum of 12'-0" counterclockwise (in plan view) from the ladder in 2 sections and shall extend a minimum of 6'-0" clockwise in 1 section. Each end of the guardrail shall terminate with an additional 6'-0" (min.) section of guardrail running toward the center of the tank. Include an "alleyway" (4'-0" min. length) at the ladder. The inboard end of the alleyway shall be

protected with a self closing gate that is permanently attached to the post on one side such that it opens toward the tank center.

- D. Provide welded attachment between the new guardrail and the existing ladder cage at a minimum of 2 locations on each side opposite of the top and intermediate rails.
- E. Install new level gauge at the same approximate location of the existing level gauge (opposite of the high inlet).
- F. Install the new roof vent as required.
- G. Install the new roof hatch as detailed on the drawings. Roof layout shall be similar to the adjacent tank MG#1 as shown in Appendix D.
- H. Provide support of the existing PVC inlet pipe using SS flat bar and clamp (see Appendix D for approved detail used on MG#1).
- I. Weld 2 fall protection anchor lugs at locations by the engineer. Install cable lanyards pursuant to the special provisions.
- J. Install welded steel patches to cover shell vents, misc. holes, corrosion or other as directed by the Owner's Representative. The patches shall lap the existing shell or bottom areas and shall be fully seal welded around the perimeter on interior and exterior (see Appendix D). Patch repairs shall conform to API 653. Patches shall be finish sanded to remove all sharp edges and round all corners to 1/8" minimum radius.

END OF SECTION

Section 13020

REPLACE WATER TANK ROOF

PART 1 - GENERAL

1.01 SUMMARY

The Contractor shall remove the existing roof and provide a new (replacement) roof for a flat-bottom welded steel water storage tank. The new roof shall be a formed structural roof panel system with exterior structure. The tank roof and completed tank system shall be suitable to provide potable water storage and emergency (including post-earthquake fire suppression) service. The Contractor shall design, fabricate, coat and erect all aspects of the tank roof structure system, including the foundation (center column base plates), pursuant to AWWA D100-21 (including Section 13 for seismic design, CBC 2019, California Department of Public Health Drinking Water Statutes, and all other applicable rules and regulations). NSF/ANSI 61 (Standard for Drinking Water System Components) shall apply. All contractor design calculations and drawings shall be stamped by a registered Professional Civil or Structural Engineer with design experience on over 50 similar welded steel tanks.

1.02 RELATED WORK SPECIFIED ELSEWHERE

- A. Section 01100, Scope and Control of the Work
- B. Section 16600, Cathodic Protection System
- C. Section 13010, Upgrades to the Existing Tank
- D. Section 09800, Protective Coatings

1.03 REFERENCES

The latest edition of standards and regulations herein form a part of this specification. Design details, repair methods, fabrication, erection, and all other aspects of the work and inspections shall conform to following codes and standards:

- A. AMERICAN WATER WORKS ASSOCIATION (AWWA)
 - 1. AWWA D100-11, AWWA Standard- Welded Carbon Steel Tanks for Water Storage
 - 2. AWWA C652-11, AWWA Disinfection of Water-Storage Facilities
- B. CALIFORNIA BUILDING STANDARDS COMMISSION (CBSC)
 - 1. CBC 2019, California Building Code
- C. NATIONAL ASSOCIATION OF CORROSION ENGINEERS (NACE)
 - 1. Standard RP0178-91, Design, Fabrication, and Surface Finish Practices for Tanks and Vessels to Be Lined for Immersion Service

- D. ASTM INTERNATIONAL
 - 1. ASTM A53/A53M, Standard Specification for Pipe, Steel, Black and Hot-Dipped, Zinc-Coated, Welded and Seamless
- E. AMERICAN SOCIETY OF CIVIL ENGINEERS (ASCE)
 - 1. ASCE/SEI 7, Minimum Design Loads For Buildings and Other Structures
- F. AMERICAN PETROLEUM INSTITUTE (API)
 - 1. API 653-Latest, Tank Inspection, Repair, Alteration and Reconstruction
- G. AMERICAN WELDING SOCIETY (AWS)
 - 1. AWS D1.1:2010 Structural Welding Code - Steel
- H. NATIONAL SANITATION FOUNDATION (NSF)
 - 1. NSF 61, Drinking Water System Components - Health Effects

1.04 DEFINITIONS

- A. Roof Structure: For the purposes of this project, roof structure includes all portions of the roof plate and roof support system between the existing shell and the tank bottom. This includes rafter attachment “clips” at the shell, rafters, rafter bracing, center support, center column and base plate.

1.05 SUBMITTALS

- A. Engineering calculations. These will show the structural adequacy of all significant design items on the roof structure including but not limited to support of the roof plate considering its existing thickness, rafter sizing, center support, columns and base plate. The Contractor shall provide additional design calculations to show structural adequacy of additional structural items where structural loads are specified by applicable industry standards. The design calculations and detailed drawings shall be signed by a Civil or Structural Engineer licensed to practice in the state.
- B. Drawings and supplemental information. These will include: dimensional drawings (indicating size and thickness of all members), attachment details, fabrication details, testing and inspection requirements and all details of welded joints. Weld joint details shall include size, joint preparation, identification of field welds, and indication of welds requiring low hydrogen procedures.
- C. Welding Procedures
- D. Welder Certifications
- E. Mill Test Reports (including columns, rafters, associated plate)
- F. Temporary door sheet design and details drawings (if Contractor selects to use door sheet(s)).

1.06 DESIGN INFORMATION

- A. Diameter: Approximately 66'-0". Dimension shall be confirmed by the Contractor
- B. Shell Height: Approximately 40'-0". Dimensions shall be confirmed by the Contractor
- C. The center base plates shall be designed pursuant to 3,750 psf total allowable soil bearing pressure (including weight of water at 39 ft.).
- D. Roof Type: cone
- E. Roof Structure:
 - 1. The roof shall be a "single bay" design.
 - 2. Roof structure shall be integrally formed with roof plate. The structural sections shall be on the top of the roof similar to the new roof on the adjacent water tank (MG#1).
 - 3. The roof design shall use a ring with a minimum of 3 "center" columns located at an approximately 5'-0" radius to allow optimal access for seal welding and coating. This ring of center columns shall support a circular "ring girder" with a nominally rectangular cross section. The top of the "ring girder" shall be sloped to match the pitch of the roof. The minimum wall thickness of the ring girder shall be 5/16".
 - 4. The minimum thickness of the flanges of the roof support "rafters" (or equivalent structure) shall be 1/4".
 - 5. "Rafter" quantity: 46 (minimum) and the quantity shall be adequate for the snow load and roof plate thickness.
 - 6. The lowest column base plates shall be a minimum of 3/4 inch thick and welded to the bottom. The columns shall have "end plates" that are retained laterally but shall be a "floating design" (not welded to the tank bottom).
 - 7. Lowest column base plate(s) shall be welded to the bottom but shall have a floating upper plate.
 - 8. All nuts and bolts in the roof structure shall be hot dip galvanized.
- F. Roof live load: 70 psf
- G. Roof plate minimum thickness: 1/4"
- H. Roof slope:(to be confirmed by Contractor)
- I. Allowable soil bearing pressure:3,750 psf
- J. Temporary door sheet: If used, door sheet design shall conform to API 653.

PART 2 - PRODUCTS

2.01 BASE PLATES

- A. Plate shall conform to the design requirements of AWWA D100 and ASTM A36

2.02 STRUCTURAL SHAPES

A. COLUMN(S)

Columns shall be round tubular with minimum thickness of 1/4". Pipe shall conform to the design requirements of AWWA D100 and ASTM A53.

B. RAFTERS

Rafters shall conform to the design requirements of AWWA D100 and ASTM A36 or A992

2.03 PLATE AND SHEET

A. Plate and sheet materials shall conform to the design requirements of AWWA D100.

2.04 DOOR SHEET

A. The Contractor may install a temporary door sheet (at their option) for improved access. The temporary door sheet shall conform to AWWA D100 and API 653 (latest).

PART 3 - EXECUTION

3.01 QUALITY

A. Shop and field welding quality control shall be the responsibility of the Contractor. Quality assurance inspection oversight and CBC required special inspection will be provided by the Owner's Representative. To help insure effective and efficient oversight, the Owner's quality assurance shall be conducted by or under the oversight of an experienced tank design engineer with minimum qualifications of a California PE Registration, AWS CWI and API 653 Tank Inspector Certification. Safe access and lighting are an important aspect of producing a quality product for both the contractor personnel and quality assurance personnel. Safe access, lighting, and assistance shall be provided by the Contractor for the Owner's Representative(s) using the Contractor's rigging and equipment to allow inspection or observation of all work. This shall be provided by the Contractor at no additional cost. The Contractor shall provide written notification to the Owner's Representative at least 48 hours in advance of the start or re-start of each work phase.

B. Radiographic testing and other AWWA D100 required nondestructive testing shall be provided at the expense of the Contractor. The intent of nondestructive testing on this project is to confirm that welds meet the specified minimum requirements. Radiography shall be conducted pursuant to the requirements of AWWA D100 with the following changes: 100% of all the vertical and horizontal shell welds used to replace the door sheet shall be radiographed. The quantity of locations for radiography in other locations shall be increased by adding one additional location on each of the vertical joints in the lowest two shell rings; the locations for all radiographic testing shall be selected by the Owner's Representative. For each weld where quality is found to be unacceptable, the AWWA D100 procedure will be followed regarding additional locations and two supplementary radiographs shall be taken at locations selected by the owner's representative (in addition to the "tracer" locations required by AWWA D100). A copy of the radiographic inspection report shall be provided to the Owner's Representative.

3.02 GENERAL FABRICATION AND WELDING

A. Finishing of Corners and Edges

All corners and edges that are exposed upon completion of fabrication shall be finished to a minimum radius of 1/16" to optimize coating application. Finishing with grinding wheels may produce "hard" corners which are not acceptable. The Contractor shall use grinders equipped with "soft pads" or sanding discs on rubber backing where required to produce acceptable finishes and rounding of corners and edges.

B. Weld Profiles and Finishing

The maximum weld reinforcement allowed by AWWA D100 shall be reduced by 1/32" for all butt joints on this project. Weld reinforcement shall transition to the base metal in a manner that minimizes the mechanical notch at the toe of the weld. The maximum angle between the weld reinforcement and the adjoining base metal shall be 45 degrees. Welds with a less gradual transition shall be repaired by grinding followed by sanding to smooth course grinding marks (deeper than 4 mils as measured with profile tape) and radius any angular transitions.

All weld spatter shall be removed prior to coating. Abrasive blasting is not reliable for removal of all weld spatter so all weld spatter shall be removed as a part of tank erection and prior to the start of abrasive blasting.

C. Removal of Temporary Attachments

All temporary and unnecessary brackets, lugs, and clips, such as those used during erection, shall be removed from the tank. Pits created during removal shall be repaired with consideration of minimum weld length and accepted welding procedures. Welded repairs shall be ground flush. Removal of temporary attachments shall be by grinding followed by sanding in order to smooth course grinding marks (deeper than 4 mils as

D. Coating

1. The tops of rafters and other areas that will be inaccessible after erection, shall be shop coated with the full system for interior surfaces according to these specifications.

3.03 DOOR SHEET

A. If the Contractor chooses to use a door sheet (temporary shell opening), the removal and installation shall be pursuant to API 653 and the following:

1. All welding shall be with low hydrogen processes.
2. Plate edges shall be built up with low hydrogen electrode to replace material lost in the kerf of the cut during the removal of the door sheet. This must be done prior to beveling. The purpose is to help prevent a flat spot in the shell upon replacement.

END OF SECTION

Section 16600

IMPRESSED-CURRENT CATHODIC PROTECTION SYSTEM

PART 1 - GENERAL

1.01 SCOPE

- A. The cathodic protection design/install constructor shall provide all engineering services, materials equipment, labor, and supervision to furnish an automatically controlled, impressed-current cathodic protection system to provide corrosion control for the interior submerged surface of the specified tank. All work furnished shall be in accordance with National Association of Corrosion Engineers (NACE) and American Water Works Association (AWWA) Standard D104-11 and features included in this specification.

1.02 RELATED WORK SPECIFIED ELSEWHERE

- A. Section 01100, Scope and Control of the Work
- B. Section 13020, Replace Water Tank Roof
- C. Section 09905, Protective Coatings

1.03 REFERENCES

The latest edition of standards and regulations herein form a part of this specification. Design details, repair methods, fabrication, erection, and all other aspects of the work and inspections shall conform to following codes and standards:

- A. AMERICAN WATER WORKS ASSOCIATION (AWWA)
 - 1. AWWA D100-11, AWWA Standard- Welded Carbon Steel Tanks for Water Storage
 - 2. AWWA D104-17, AWWA Standard- Automatically Controlled, Impressed-Current Cathodic Protection for the Interior Submerged Surfaces of Steel Water Storage Tanks
- B. NATIONAL ASSOCIATION OF CORROSION ENGINEERS (NACE)
 - 1. NACE SP0388-2018, Standard Practice - Impressed Current Cathodic Protection of Internal Submerged Surfaces of Carbon Steel Water Storage Tanks
 - 2. NACE SP0178-2007, Design, Fabrication, and Surface Finish Practices for Tanks and Vessels to Be Lined for Immersion Service.
- C. NATIONAL SANITATION FOUNDATION
 - 1. NSF 61, Drinking Water System Components - Health Effects

1.04 DESIGN

- 1. The system shall be designed by a corrosion specialist who is certified by NACE, as a Senior Corrosion Technologist or a Cathodic Protection Specialist, with not less than 5

years design experience on cathodic protection systems for water storage tanks. The corrosion specialist shall design the system to provide effective corrosion control in accordance with criteria for protection. The criteria for protection shall be based on a tank-to-water potential, free of IR drop error, within a range of -0.850 volts to -1.050 volts relative to a copper-copper sulfate reference electrode. This potential shall be measured free of the effect of voltage gradients (IR drops).

- B. The corrosion specialist shall also base system capacity and performance on:
1. Total submerged surface area of the tank. Ground storage total surface area includes floor (sidewalls to the TCL). Consideration shall be given to other submerged structures known to have metallic mass in contact with the water.
 2. Type of coating and condition of coating.
 3. Total design surface area to be protected shall be a minimum of 25 percent of total submerged surface area.
 4. Minimum design current density of 0.5 mA/ft.² bare surface area.
 5. Chemical analysis of water (including resistance expressed in ohm-cm).
 6. Susceptibility of tank to icing (this project tank is not subject to icing).
 7. Minimum anode system life of 20 years.
 8. Selection, dimensions, and layout of system components specified in Section C.

1.05 SUBMITTALS

- A. The cathodic protection constructor shall submit the following information to the purchaser for approval by the Owner's Representative:
1. System design calculations signed by corrosion specialist with NACE certification number.
 2. Corrosion specialist proof of experience designing water tank cathodic protection systems.
 3. Drawings showing system design/configuration and equipment layout.
 4. Description of system components.
 5. Cathodic protection contractor proof of experience.
 6. NSF-61 certification of all CP system materials within the tank.

PART 2 - PRODUCTS

2.01 RECTIFIER

- a. In order to maintain continuity with existing District Owned CP systems, the CP rectifier unit shall be manufactured Tank mounted IRT C.P. Sentinel Aqua-Line Cathodic Protection Rectifier.

- B. The rectifier cabinet shall be mounted to a stainless-steel utility bracket such as unistrut or equal. The brackets shall be located on the tank shell near the exterior ladder with the meters placed at eye level (5'6"). All attachments to the tank shall be seal welded and a 6" minimum clear space shall be provided between the tank shell and the cabinet for future painting and maintenance.
- C. The rectifier shall include:
1. Transformer. Primary with secondary winding type, including;
 - a. allowance for not less than 25 incremental settings from 0 to 100 percent of full rating of the rectifier unit;
 - b. pre-heated varnish dipped and baked dry for maximum moisture and corrosion resistance;
 - c. securely mounted within the cabinet behind the front instrument panel.
 2. Silicon full-wave bridge rectifying elements.
 3. Assembly on a single aluminum chassis that allows for easy removal of all components from the cabinet in one unit.
 4. AC circuit breaker(s) of the magnetic type.
 5. Lightning, surge, and overload protection.
 6. Individual 3.5 digit Voltmeter(s) and ammeter(s) with extra bright LED digital display.
 7. Waterproof 14 gauge steel cabinet in accordance with NEMA 4 requirements. Cabinet shall be mill galvanized with 3+ mils polyester fusion bonded powder paint (white).
 8. Provisions for mounting, grounding, and locking.
 9. A selector switch that allows for automatic or manual control.
 10. Provision to vary current output from 0 to 100 percent of rated capacity.
 11. Provision for 110-130 volt, 60 Hz, single phase AC power.
 12. D.C. output capacity in volts and amperes in accordance with Design (Section B).
 13. Number of circuits or separate rectifiers in accordance with Design (Section B).
 14. A dead front panel. All energized components or terminals shall be electrically shielded or located behind the front panel.
 15. An AWWA D104-11, Type A automatic controller, with adjustable current output to compensate for changes in water level, temperature of water, water chemistry, and cathodic polarization. The following provisions shall be met:
 - a. Long-life solid-matrix copper-copper sulfate reference electrode(s) mounted within the tank per the design.

- b. Monitoring of the tank-to-water potential, free of IR drop error.
- c. Automatically adjust the tank-to-water potential, free of IR drop, to a preset value (Section B).
- d. Operate within 5 mV of field set potential value.
- e. Automatically limit current and/or voltage to a preset value with LED status indication.
- f. Utilize potential meter(s) to display tank-to-water potential, free of IR drop.
- g. The potential meter shall be extra bright LED digital display. Range of operation to be not less than +0.400 to -1.999 Volt.
- h. Include a potential/set switch to allow monitoring of potential or set-potential via potential meter display. Switch shall be spring loaded to automatically return to the monitoring position.
- i. Potential gathering and controller circuitry shall be high impedance of not less than 20 megohms. Reference cell inputs shall be galvanically isolated from the controller circuit.
- j. The tank to water potential (free of IR drop error) shall NOT be permitted to overshoot the pre-set value during initial startup, nor during normal operation; to prevent coating stress due to excessive polarization. At no time should the controlled potential or the preset potential be more negative than -1050 mV.
- k. Potential monitoring alarm circuit, field adjustable with green & red lights mounted on the exterior of the cabinet door. Alarm circuit shall have dry contacts that would show proper potential being maintained and not proper potential. A terminal block shall be connected to the alarm circuit NO & NC relays which will allow for future connection of remote monitoring wiring.

2.02 LONG LIFE REFERENCE ELECTRODE(S)

- A. The reference electrode shall consist of a copper-copper sulfate electrode which is of a solid matrix design manufactured to remain stable (plus or minus 10 mV) for a minimum of 20 years. The reference electrode lead wire shall be not less than AWG #14 type RHW (yellow). The connection shall be encapsulated to prevent water migration.

2.03 ANODE SUSPENSION SYSTEM

- A. The anode suspension system for non-icing tanks shall be a system which allows for vertical suspension from the roof of the tank. The anode lead wire shall be a minimum #10 HMW/PE or RHW/USE for precious metal anodes and will be used to secure the lead wire to a porcelain insulator bracket bolted to the interior of the tank roof.
- B. The anode suspension system for icing tanks shall consist of a minimum 5/16" polyester braid on braid cord. The cord shall be secured to steel anchors welded to the side wall of the tank bowl or to the exterior of the dry access column of spheroidal type tanks and the

side wall of wet risers which are 30" diameter or larger. All cord to cord connections shall be tied, taped, and wire tied.

- C. Anode and/or test hand hole shall be 5" in diameter, cut in the tank with edges ground smooth, and coated. Hand hole assemblies used for the installation of vertical anode suspension systems from the roof of the tank shall consist of a 6" diameter hot dip galvanized steel cover plate, neoprene gasket, EPDM or neoprene grommet on roof plate hole and a PVC clamping bar held in place by a ½" SS bolt.

2.04 ANODE MATERIALS

- A. The anode materials shall be selected in accordance with Design (Section B) and shall consist of one of the following types:
 - 1. Minimum .062" diameter platinized niobium with 25 micro inches of platinum.
 - 2. Minimum .062" diameter titanium with a precious metal oxide coating.
 - 3. All anode-to-header cable connections shall be factory sealed in a proven manor to prevent water migration to the header cable anode connection.

2.05 WIRING

- A. All wiring within the tank shall be AWG # 10 or larger type HMW/PE or RHW/USE with the exception of the reference cell (section C2) and the automatic controller wiring, which may be not less than AWG # 18 type TW.
- B. All wiring on the exterior of the tank shall be type THHN or TW and run in rigid galvanized conduit.

2.06 HARDWARE

- A. All metallic hardware used in conjunction with the system shall be hot dip galvanized, or coated pursuant to the tank coating specification.
- B. Hand hole covers shall be stainless steel.
- C. Channel type EPDM grommets are required at hand holes

PART 3 - EXECUTION

3.01 QUALIFICATIONS

- A. The cathodic protection constructor shall have a minimum of 5 years' experience installing and servicing the types of system described in this specification. The system shall be installed by employees of the cathodic protection constructor and trained in the installation of waterworks and related cathodic protection systems.

3.02 PERFORMANCE

- A. All work shall be in accordance with the following requirements:

1. Components of the cathodic protection system shall be installed in the manner and at the locations as shown on the approved design drawings prepared by the corrosion specialist.
2. Welding, cutting, and coating shall be in accordance with AWWA Standards D100, D102, and D105. Access holes shall be finished with a 1/16" minimum radius using a soft abrasive pad. Access holes and other holes shall be cut prior to tank coating.
3. Welding of steel coupling, anchors, and mounting bracket shall be furnished by the prime contractor prior to coating the tank. The cathodic protection constructor shall furnish approved design drawings of hardware installation and materials to the prime contractor prior to coating.
4. Electrical continuity of all sections of bolted or riveted tanks shall be furnished by the tank erector or prime contractor.
5. Materials and equipment shall be inspected prior to installation. Any defective component shall be repaired or replaced.
6. Electrical work shall be in accordance with the National Electrical Code and/or local code.
7. Lead wires shall be installed to prevent damage from abrasion.
8. Electrical connections within the tank shall be sealed to prevent water migration.
9. The rectifier shall be mounted at a convenient height (eye level) above grade for easy monitoring and service purposes.
10. Disinfection shall be the responsibility of the purchaser.
11. Work provided by the cathodic protection constructor shall be completed in a clean and safe manner.

3.03 ENERGIZING THE SYSTEM

- A. After the system is installed and the tank is filled, the cathodic protection constructor shall demonstrate to the Owner or his representative that the cathodic protection system is operating properly, at which time the system shall be shut OFF, fuses pulled, anode lead wire disconnected from the rectifier positive terminal, and secured. After the 11-month coating inspection and the tank is refilled, the cathodic protection constructor shall provide start-up service which includes energizing, testing, and adjusting the system for optimum performance of the cathodic protection system.
- B. This reenergizing service shall be requested by the Owner and coordinated with the Owner and/or his representative.
- C. All tank-to-water potential measurements shall be conducted with a calibrated portable copper-copper sulfate reference electrode and a portable high impedance voltmeter. A minimum of 5 locations shall be measured. All test data shall be reviewed and evaluated by the corrosion specialist then forwarded to the owner.

3.04 MONITORING

- A. The cathodic protection constructor shall furnish e-mail address and an e-form to record monthly system reading. The form shall be sent by the owner monthly. Monthly readings received by the cathodic protection constructor during the guarantee and/or service period(s) shall be evaluated for system performance and compliance with AWWA Standard D104-11. Deviations in the readings will warrant further investigation by the cathodic protection contractor.

3.05 GUARANTEE

- A. All workmanship, equipment, and materials furnished by the cathodic protection constructor shall be guaranteed for not less than 1 year from the date of the second (after warranty coating inspection) and final energizing of the system. This guarantee would not exceed 2 years from date of original energizing of the system.

3.06 SERVICE AGREEMENT PROPOSAL

- A. The cathodic protection constructor shall furnish the owner with a service agreement proposal for the type of system installed. The agreement shall include the annual service rate and a complete description of the scope of work proposed.
- B. The agreement for annual inspection and potential testing shall include as a minimum:
 - 1. 1 annual job site visit.
 - 2. Tank-to-water potential measurements conducted at representative locations within the tank. A minimum of 5 locations shall be measured.
 - 3. Tank-to-water potential test locations shall be representative of the high and low potentials to be encountered within the tank.
 - 4. Measurements shall be conducted with a portable high impedance voltmeter and a calibrated copper-copper sulfate reference cell.
 - 5. Adjustments for optimum corrosion control shall be in accordance with criteria for protection.
 - 6. Data recorded shall provide sufficient information to evaluate the performance of the system relating to criteria for protection.
 - 7. In the event additional work is required, the constructor shall submit a report with recommendations for optimizing the corrosion control system.

END OF SECTION

**PART VIII
PROJECT DRAWINGS**

PROJECT PLANS FOR TWIN HARTE COMMUNITY SERVICES DISTRICT'S WATER TANK #2 RECOATING AND UPGRADE PROJECT



DRAWING TABLE OF CONTENTS

1. COVER
2. MG #2 PARTIAL PLAN
3. ROOF STRUCTURE
4. ROOF FALL PROTECTION
5. LADDER DOOR & ROOF HATCH
6. ROOF VENT



ADVANTAGE TECHNICAL SERVICES, INC.
805-595-2282
ATS-SLO.COM



DRAWING NOTES:

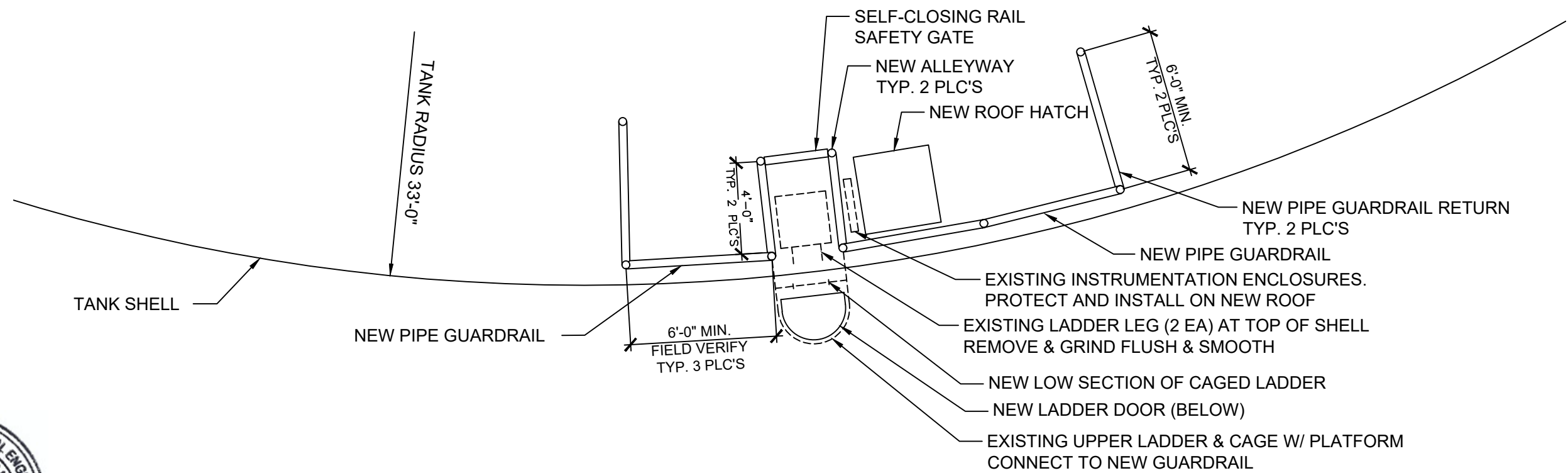

1. PROVIDE REPLACEMENT ROOF AND INSTALL NEW ROOF APPURTENANCES AS REQUIRED (CONTRACTOR TO FIELD VERIFY RADIUS).
2. INSTALL NEW ROOF HATCH AND ROOF GUARDRAIL PURSUANT TO THESE PROJECT DOCUMENTS.
3. ALL COMPONENTS INCLUDING GUARDRAIL SHALL CONFORM TO THE OSHA CFR PART 1910. LENGTHS OF NEW GUARDRAIL ARE MINIMUM.
4. CONTRACTOR SHALL FIELD VERIFY ALL DIMENSIONS PRIOR TO FABRICATION.
5. WELD 2 FALL PROTECTION ANCHOR LUGS AT LOCATIONS SPECIFIED BY THE OWNERS REPRESENTATIVE. INSTALL CABLE LANYARDS PURSUANT TO THE SPECIAL PROVISIONS.

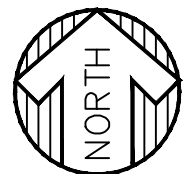

EXISTING TANK PARTIAL PLAN VIEW



Copyright © 2023 Advantage Technical Services, a California Corporation. All rights reserved

REVISIONS	DATE	 ADVANTAGE TECHNICAL SERVICES, INC. 805-595-2282 ATS-SLO.COM	DESIGNED BY:	DRAWN BY:	CHECKED BY:	RECOMMENDED:	 TWAIN HARTE COMMUNITY SERVICES DISTRICT WATER TANK #2 RECOATING & UPGRADE PROJECT	SHEET:
	00/00/00		WB	GM	JB	OPERATIONS MGR.		<u>2</u> OF <u>6</u>
			PREPARED UNDER THE DIRECTION OF:			APPROVED:	MG #2 PARTIAL PLAN	SCALE:
			 WILLIAM BELLIS P.E.			TOM TROTT, GENERAL MGR.		NTS

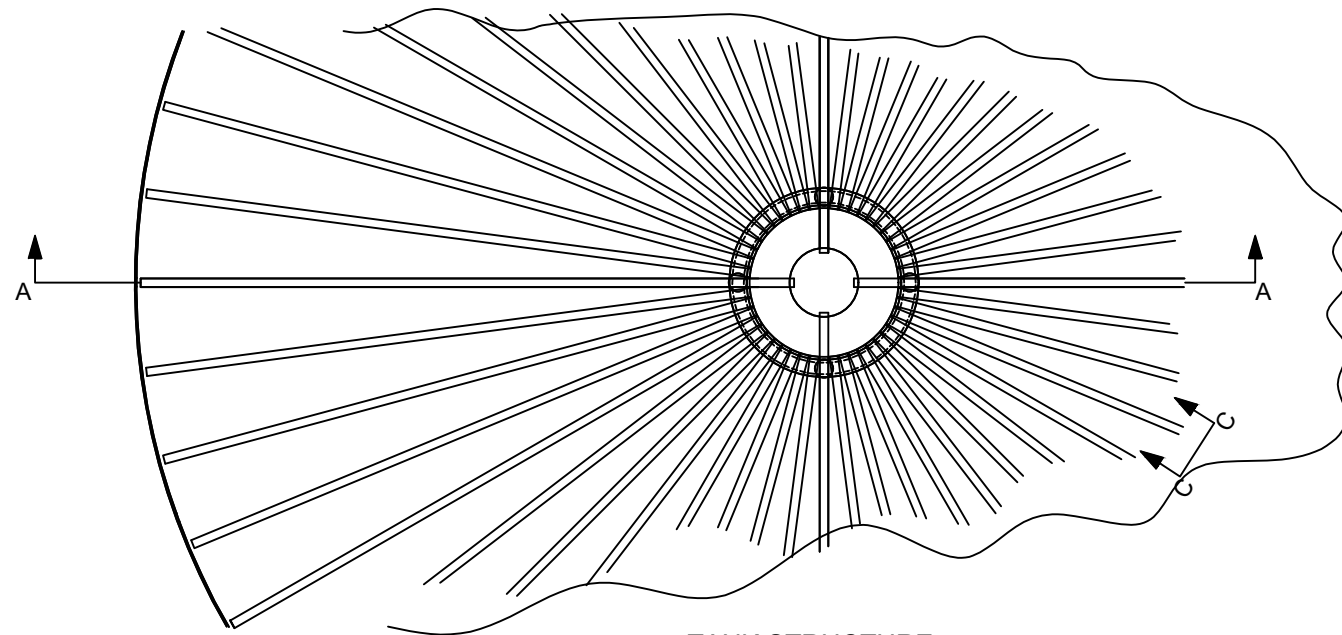

TANK STRUCTURE
PARTIAL PLAN

DRAWING NOTES:

1. REMOVE AND RECYCLE EXISTING ROOF PLATE, RAFTERS, RAFTER CLIPS, CENTER SUPPORT AND BASE PLATES.
2. "CENTER" ROOF SYSTEM COLUMNS SHALL BE ROUND HSS 5/16" MINIMUM WALL THICKNESS AND THE MINIMUM QUANTITY SHALL BE 4.
3. CENTER ROOF SUPPORT RING BEAM SHALL BE 5/16" MINIMUM THICKNESS, RECTANGULAR CROSS SECTION AND 6" DIAMETER (MIN.) AT THE CENTER LINE.
4. THE ROOF DESIGN SHALL PROVIDE A SYSTEM FOR CONTROL OF SHELL ROUNDNESS DURING ERECTION SUCH AS ERECTION BOLTS OR OTHER METHOD USING POSITIVE STOPS.
5. COLUMN BASE PLATES SHALL BE THE "FLOATING TYPE" (DESIGNED TO PREVENT THE COLUMNS FROM BEING LOADED DOWNWARD BY THE TANK BOTTOM).
6. BASE PLATES SHALL BE SEAL WELDED TO THE TANK BOTTOM TO PREVENT AN INACCESSIBLE AREA OF AREA OF BOTTOM PLATE.
7. NEW ROOF SHALL BE DESIGNED AND CONSTRUCTED W/INTEGRAL FORMED CHANNEL "RAFTERS" ON THE EXTERIOR.
8. ALL AREAS ON THE TANK INTERIOR THAT ARE INACCESSIBLE FOR COATING SHALL BE SEAL WELDED.
9. ROOF SECTIONS SHALL NOT BE PRIME COATED UNTIL AFTER FORMING.
10. ALL PLATE EDGES SHALL BE FINISHED TO A MIN. RADIUS OF 1/16" PRIOR TO ABRASIVE PREPARATION.

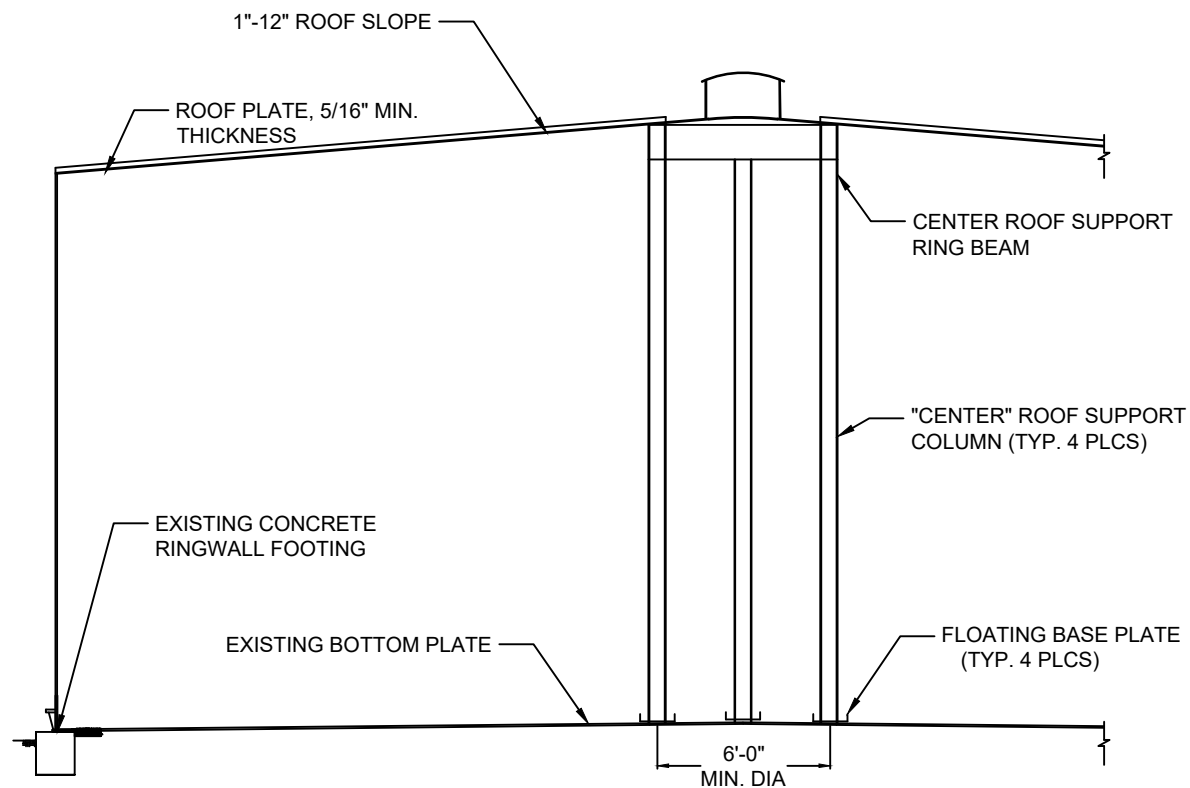

PARTIAL SECTION VIEW A-A

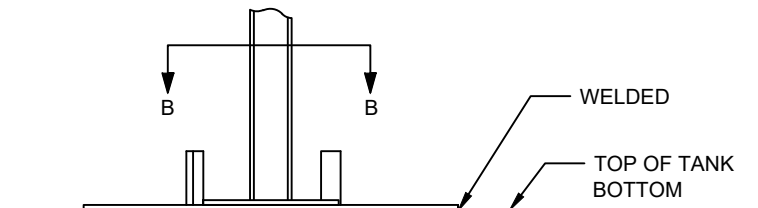

FLOATING BASE PLATE

(BASE PLATE THICKNESS AND DIMENSIONS BY CONTRACTOR'S ENGINEER)

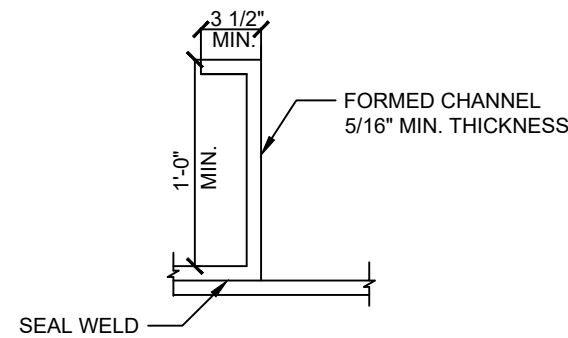

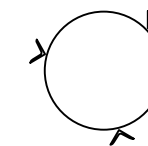

FORMED ROOF SECTION C-C



SECTION VIEW B-B



Copyright © 2023 Advantage Technical Services, a California Corporation. All rights reserved

REVISIONS	DATE	 ADVANTAGE TECHNICAL SERVICES, INC. 805-595-2282 ATS-SLO.COM	DESIGNED BY:	DRAWN BY:	CHECKED BY:	RECOMMENDED:	 TWAIN HARTE COMMUNITY SERVICES DISTRICT WATER TANK #2 RECOATING & UPGRADE PROJECT	SHEET:
	00/00/00		WB	GM	JB	OPERATIONS MGR.		DATE
			PREPARED UNDER THE DIRECTION OF:			APPROVED:	ROOF STRUCTURE	SCALE:
			 WILLIAM BELLIS P.E.			TOM TROTT, GENERAL MGR.		NTS

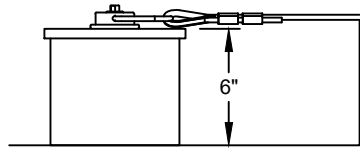
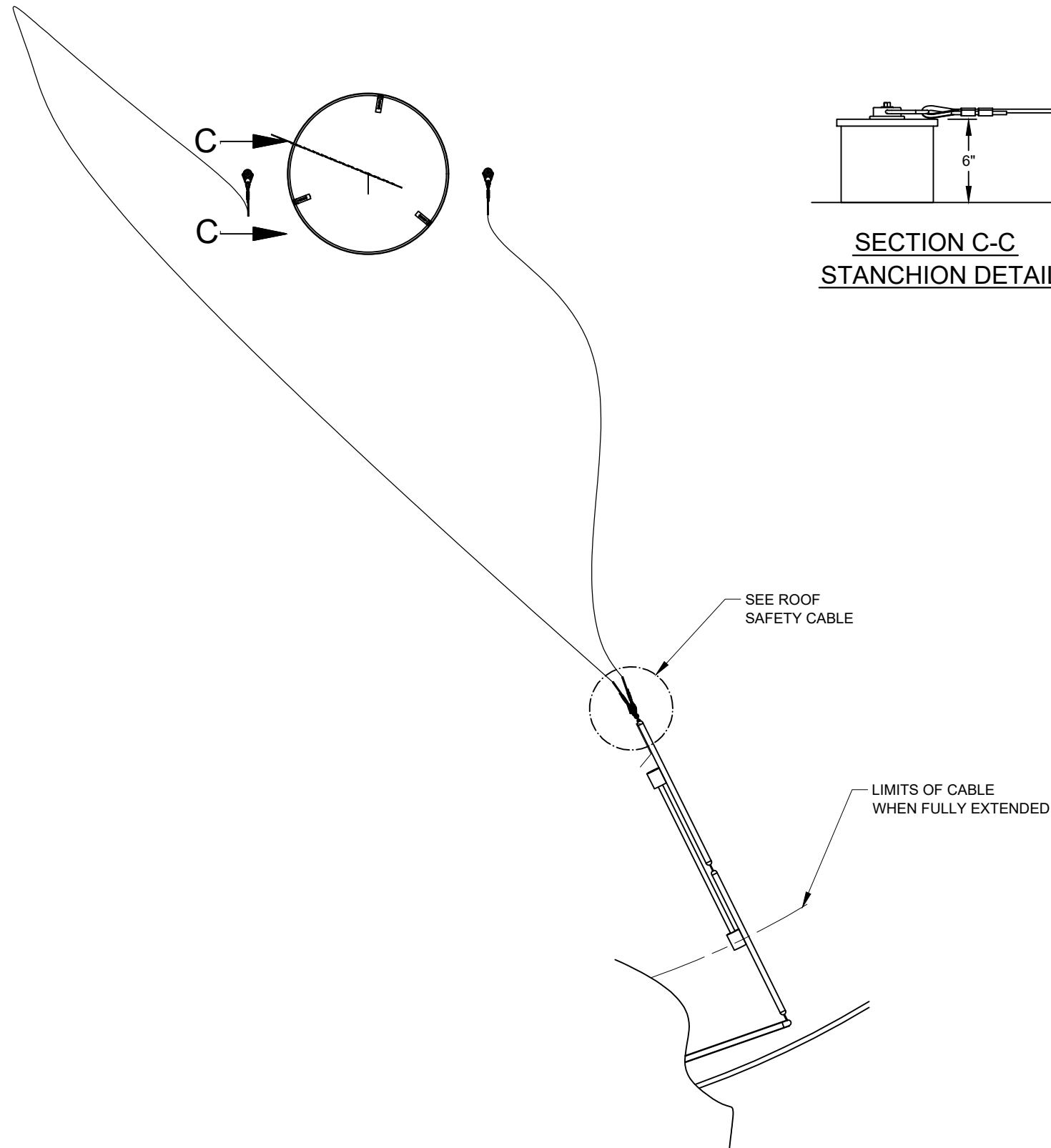

**SECTION C-C
STANCHION DETAIL**

DRAWING NOTES:

1. Remove vinyl coating from guardrail post before installing compression sleeves.
2. Verify cable does not extend further than 3'-0" from roof edge.

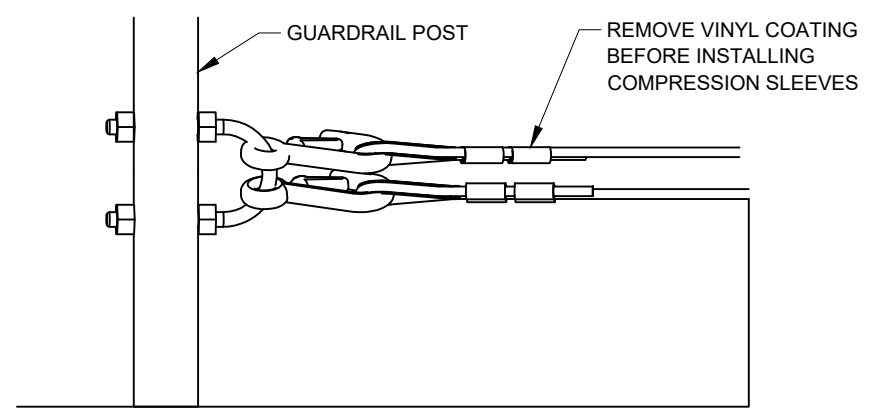

ROOF SAFETY CABLE

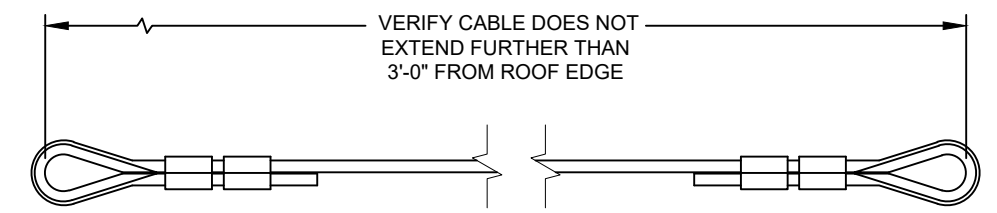



ROOF SAFETY CABLE LENGTH

ROOF GUARDRAIL-PLAN



Copyright © 2023 Advantage Technical Services, a California Corporation. All rights reserved

REVISIONS	DATE	 ADVANTAGE TECHNICAL SERVICES, INC. 805-595-2282 ATS-SLO.COM	DESIGNED BY:	DRAWN BY:	CHECKED BY:	RECOMMENDED:	 TWAIN HARTE COMMUNITY SERVICES DISTRICT WATER TANK #2 RECOATING & UPGRADE PROJECT	SHEET:
	00/00/00		WB	GM	JB	OPERATIONS MGR.		DATE
			PREPARED UNDER THE DIRECTION OF:			APPROVED:	ROOF FALL PROTECTION	SCALE:
			 WILLIAM BELLIS P.E.			TOM TROTT, GENERAL MGR.		DATE

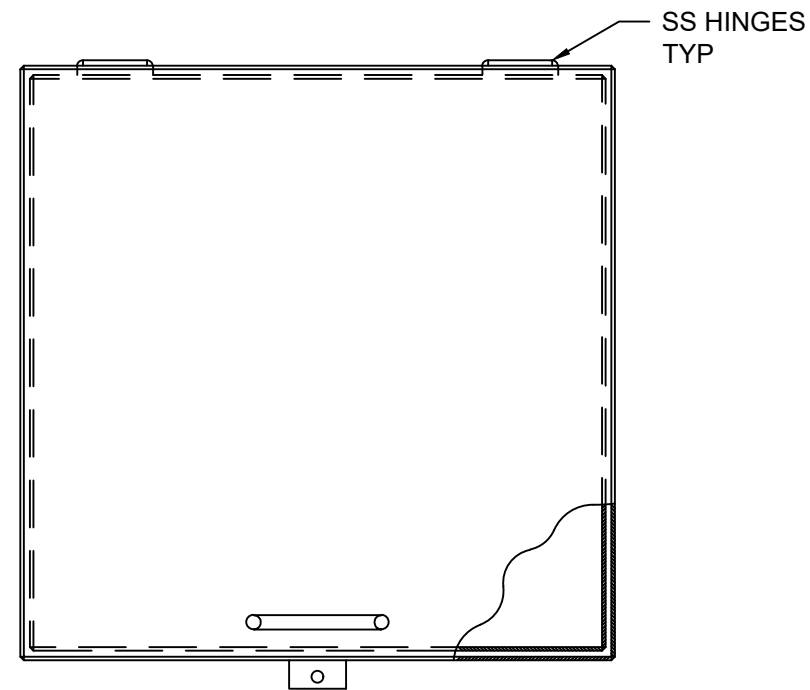

TOP VIEW

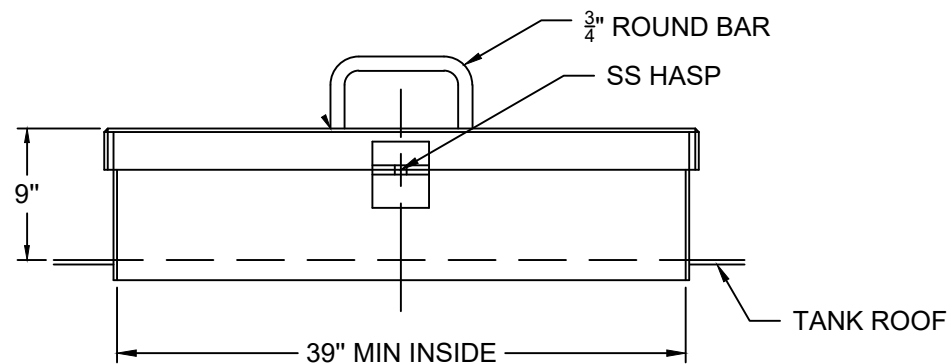

FRONT VIEW

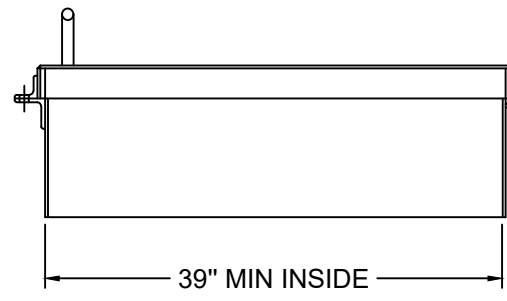

SIDE VIEW

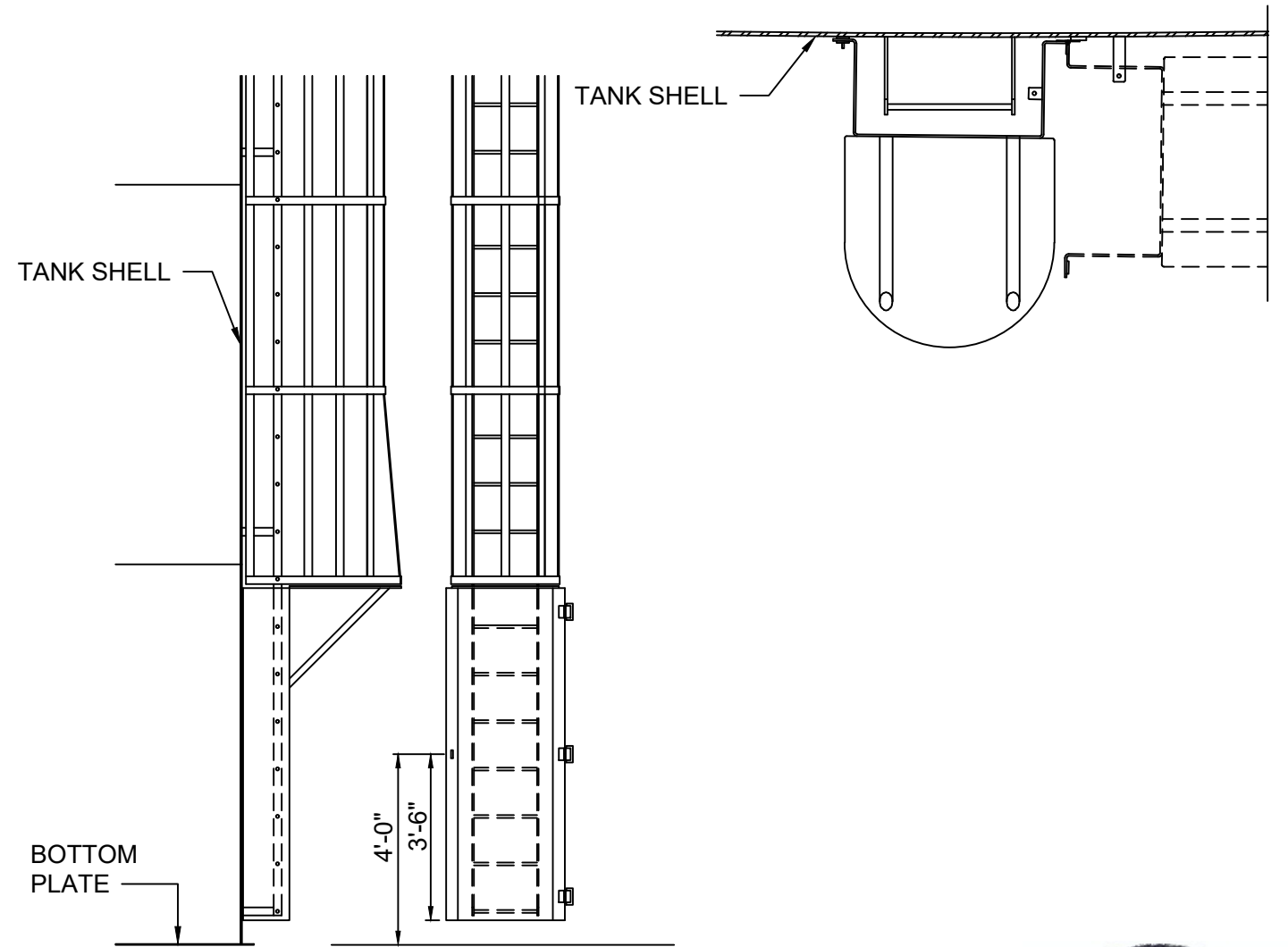

ROOF HATCH



LADDER DOOR FOR CAGED LADDER



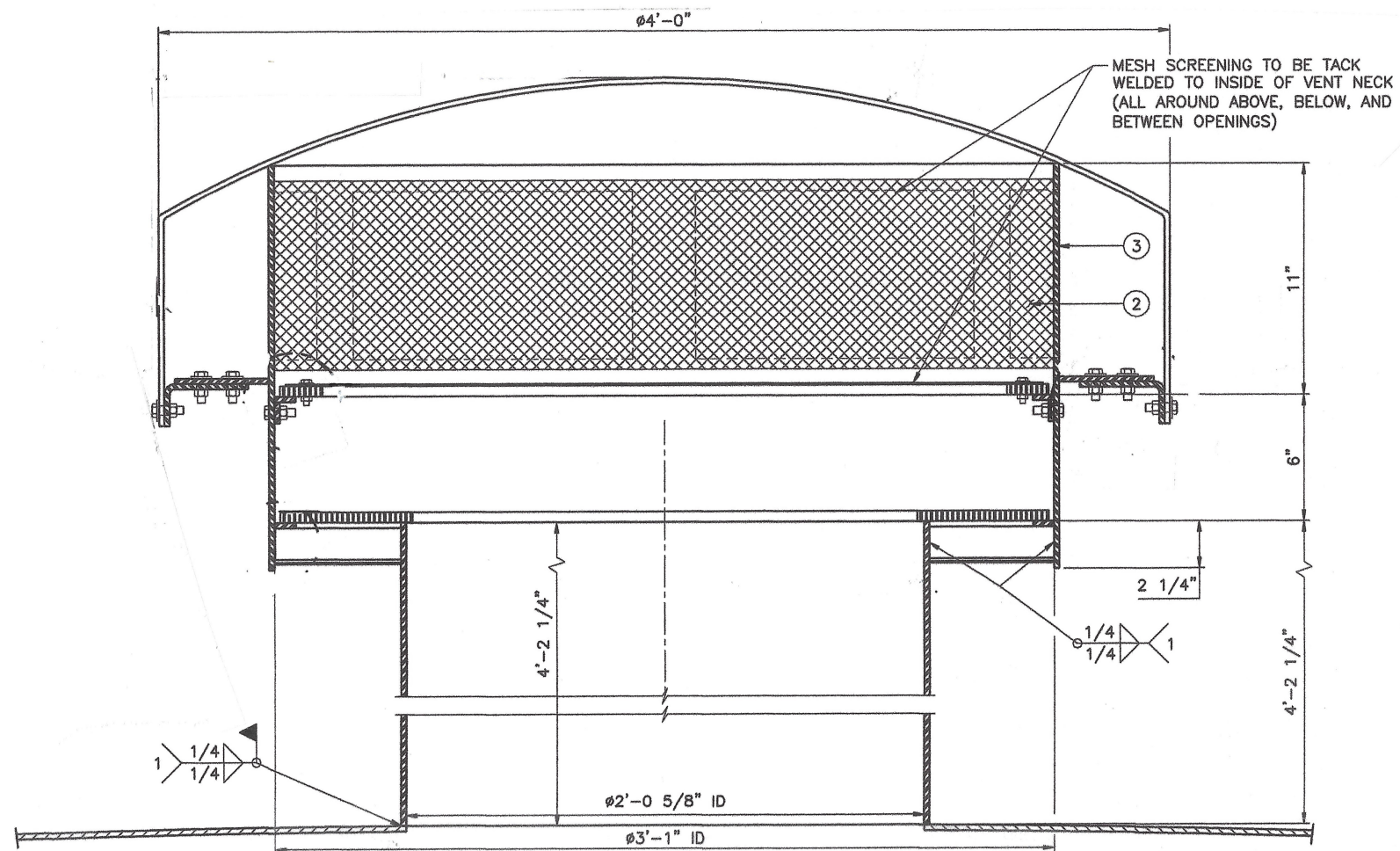

Copyright © 2023 Advantage Technical Services, a California Corporation. All rights reserved

REVISIONS	DATE	 ADVANTAGE TECHNICAL SERVICES, INC. 805-595-2282 ATS-SLO.COM	DESIGNED BY:	DRAWN BY:	CHECKED BY:	RECOMMENDED:		TWAIN HARTE COMMUNITY SERVICES DISTRICT WATER TANK #2 RECOATING & UPGRADE PROJECT	SHEET:
	00/00/00		WB	GM	JB	OPERATIONS MGR. _____ DATE _____			5 OF 6
			PREPARED UNDER THE DIRECTION OF:			APPROVED:	LADDER DOOR & ROOF HATCH	SCALE: NTS	
			 WILLIAM BELLIS P.E.			TOM TROTT, GENERAL MGR. _____ DATE _____			



24" PRESSURE/VACUUM ROOF VENT

Copyright © 2023 Advantage Technical Services, a California Corporation. All rights reserved

REVISIONS	DATE	 ADVANTAGE TECHNICAL SERVICES, INC. 805-595-2282 ATS-SLO.COM	DESIGNED BY: WB	DRAWN BY: REV TO GM	CHECKED BY: JB	RECOMMENDED: OPERATIONS MGR. _____ DATE _____	 TWAIN HARTE PARKS & RECREATION FOR WATER SERVICE COMMUNITY SERVICES DISTRICT	TWAIN HARTE COMMUNITY SERVICES DISTRICT WATER TANK #2 RECOATING & UPGRADE PROJECT	SHEET: <u>6</u> OF <u>6</u>
	00/00/00		PREPARED UNDER THE DIRECTION OF: <i>William Bellis</i> 2/27/23 WILLIAM BELLIS P.E. DATE	APPROVED: TOM TROTT, GENERAL MGR. _____ DATE _____		24" PRESSURE VACUUM ROOF VENT		SCALE: NTS	

PART IX APPENDIX

INDEX

Section	Title
Appendix A	Coatings Heavy Metals Testing
Appendix B	Not Used
Appendix C	Dive Inspection Report – Existing Welded Tank
Appendix D	Project Location & Existing Conditions

APPENDIX A
Coatings Heavy Metals Testing



STOCKTON
ENVIRONMENTAL INC

**LEAD
SAMPLING REPORT**

CONDUCTED AT:

23363 Mountain Dr
Twain Harte, CA 95383

“Tank #02”

PREPARED FOR:

Twain Harte Community Services District
22912 Vantage Point Dr,
Twain Harte, CA 95383

C/o Tom Trott

PREPARED BY:

Stockton Environmental, Inc.
Report No. 033.23 Asb/Pb
02/13/2023

TABLE OF CONTENTS

Inspection Report

Executive Summary	Page 3 - 4
Survey Methodology	Page 4
Laboratory Results	Page 4
Recommendations	Page 5
Exclusions and Report Limitations	Page 5

APPENDICES

Site Diagram	Appendix A
Laboratory Report	Appendix B
Certification	Appendix C

EXECUTIVE SUMMARY

Introduction:

On February 8th, 2023 **Stockton Environmental Inc. (SEI)** performed an inspection for Asbestos-Containing Materials (ACM) and Lead Based Paint (LBP). Mr. Gabriel Munoz conducted asbestos and lead sample collection services for SEI. Mr. Munoz is an asbestos Certified Site Surveillance Technician (CSST) (certificate number 17-6014) and California Department of Public Health (CDPH) accredited Sampling Technician for Lead (CDPH # LRC-00005750) under the direction of Mr. Randolph Brooke, a Certified Asbestos Consultant (certificate number 05-3746) and Public Health (CDPH) accredited Lead Inspector (CDPH # LRC-00002684).

Scope of Services:

Lead Based Paint inspection was conducted to identify the presence of lead for compliance with the Occupational Safety and Health Administration’s (OSHA) and the Environmental Protection Agencies (EPA) regulatory requirements pertaining to worker protection and waste disposal.

Regulatory Limits:

Lead

- Federal regulations define “Lead Based Paint (LBP)” as containing 0.5% or greater of lead by weight.

- Compliance with the OSHA Lead in Construction Standard, 29CFR 1926.62 is required if any lead is present.

- Federal regulations define Lead Hazardous Waste” (>50 mg.kg) via Total Threshold Limit Concentration (TTLC) method.

Site Description:

The inspection was conducted at the project site identified as 23363 Mountain Dr, Twain Harte, CA 95383. “Tank #02”.

Summary of Findings

Lead - SEI's inspection of the subject site collected a total of **Four (04)** samples for analysis.

The following samples collected were reported **at or above** the EPA’s definition of “**Lead Based Paint**” (**0.5% or greater**):

Sample ID	Paint Color / Area / Sample Location	Lead % by weight
0208.01	Paint Chip-1x1-Multicolored Tank Bottom/side N	3.4 % wt
0208.02	Paint Chip-1x1-Multicolored Tank Bottom/side S	4.5 % wt

0208.03	Paint Chip-1x1-Multicolored Tank Upper/top N	5.0 % wt
0208.04	Paint Chip-1x1-Multicolored Tank Upper/top S	9.4 % wt

SURVEY METHODOLOGY

Sample Collection:

An initial walk through of the subject site was conducted to identify homogeneous suspect asbestos materials and their respective locations. This information was then used to develop a sample collection strategy. Samples were collected with an appropriate sampling tool.

Each suspect sample was sealed in its own zip lock plastic container and labeled with a unique identification number. Sampling tools were individually cleaned before and after each sample was collected to avoid sample cross contamination. Decontamination was accomplished using single use, pre-moistened cloths.

Samples were recorded on SEI's in-house chain-of-custody form. This form accompanied the samples to Triangle Environmental Services Company Inc. (TESC) and/or EMSL Analytical, Inc. (EMSL).

Sample Analysis:

Lead - Suspect samples were subjected to analysis by AA/Flame. Sample analysis was conducted in accordance with the EPA's Method 7420.

LABORATORY RESULTS

The table provides each of the materials, sample identification number, description/ and corresponding laboratory result.

Lead Paint

Sample No.	Suspect Lead Material Specific Location	Lead Concentration Percent by Weight
0208.01	Paint Chip-1x1-Multicolored Tank Bottom/side N	3.4 % wt
0208.02	Paint Chip-1x1-Multicolored Tank Bottom/side S	4.5 % wt
0208.03	Paint Chip-1x1-Multicolored Tank Upper/top N	5.0 % wt
0208.04	Paint Chip-1x1-Multicolored Tank Upper/top S	9.4 % wt

RECOMMENDATIONS

Lead:

That you consider the renovation/demolition activities of this project as “**lead related construction work**” in accordance with CCR Title 17, division 1, chapter. 8, article 1.

- All construction work where an employee may be occupationally exposed to lead containing paint, including renovation and/or demolition, must comply with the OSHA Regulation 29 CRF 1926.62 and Cal-OSHA Title 8, CCR 1523.1
- If suspect painted surfaces, not discussed in this report are discovered during future demolition/renovation operations, all general work activities which could impact the discovered painted surface should cease until confirmation sampling can be conducted.

EXCLUSIONS AND REPORT LIMITATIONS

The information contained in this report is limited to those areas and suspect materials found to be visually accessible through reasonable means.

Thank you for using **Stockton Environmental Inc.** please feel free to contact me with any questions regarding this report at (209) 451.3017.

Sincerely,

Randolph L. Brooke

Randolph L. Brook
Vice President

Appendix A

TWAIN HARTE CSD WATER TANK #2 RECOATING & UPGRADE PROJECT
APPENDIX A - COATINGS HEAVY METALS TESTING

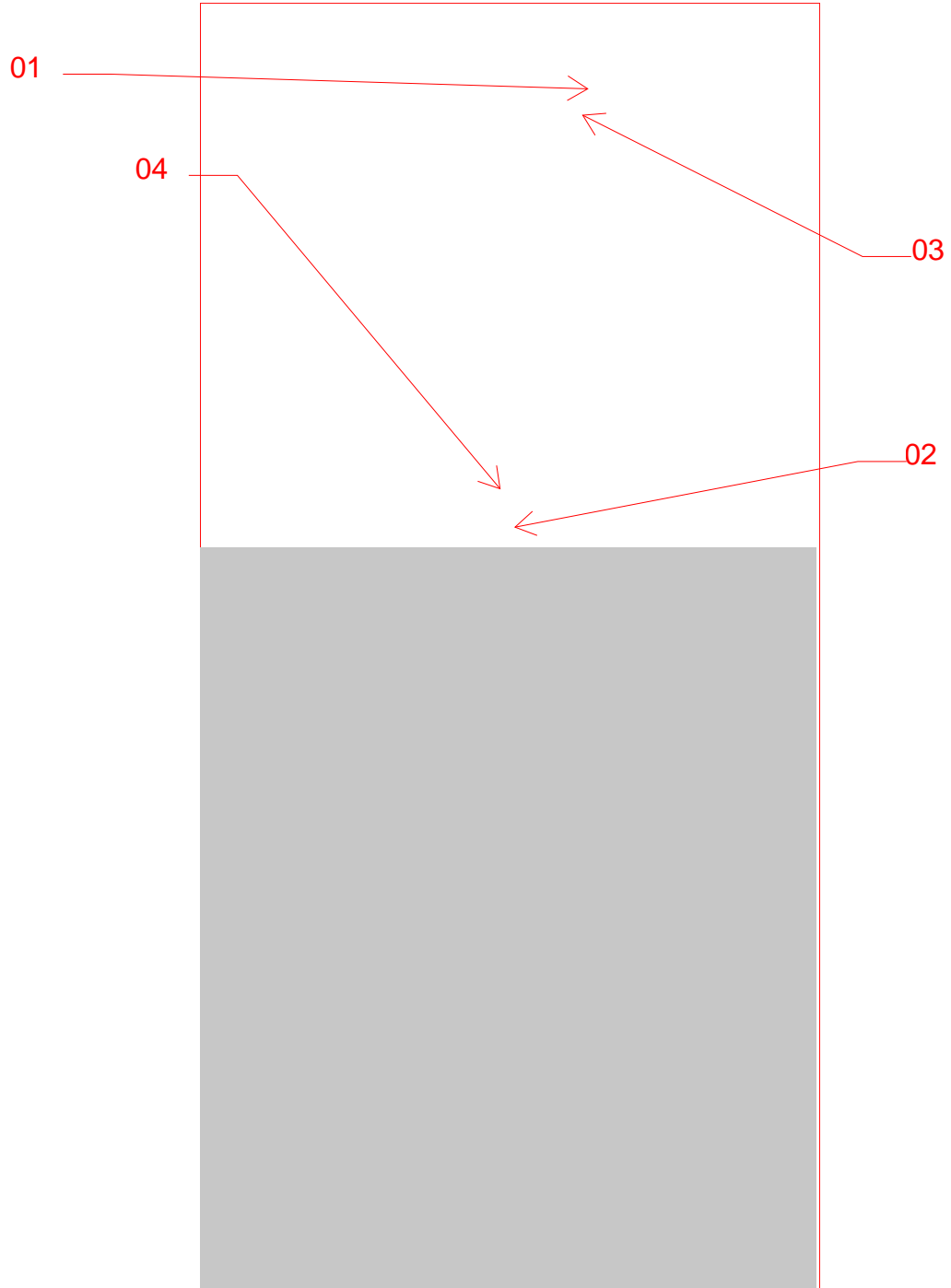

319 E. Banbury Drive - Stockton, CA 95207
7273 Murray Drive - Stockton, CA 95210
stocktonenvironmental@gmail.com

CONDUCTED AT:

23363 Mountain Dr
Twain Harte, CA 95383

"Tank #02"

PREPARED FOR:

Twain Harte Community
Services District
22912 Vantage Point Dr,
Twain Harte, CA 95383

Report No. 033.23
02/13/23

SAMPLE LOCATION
DIAGRAM

Appendix B

LEAD

CHAIN OF CUSTODY - LEAD

092303350

Page ___ of ___

Project address
COC site pic
23363 Mountain Drive

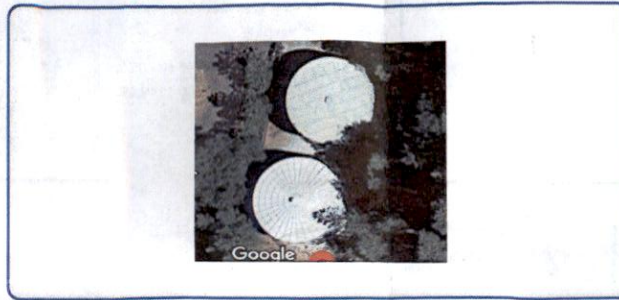

Project # 033.23

Collection Date 2/8/2023

Method of Analysis

- Flame AA
- TTLC
- STLC
- TCLP
- Other:

Turn Around

- Rush 3HR
- 6HR
- 24HR
- Other:

Technician: gbm

Laboratory: emsl

Matrix

- Bulk
- Wipe
- Paint
- Soil
- Other

Twain Harte 95383

Specific Location (s)

Water Tank

H #	Date	Count	Material type	Description	Color	Location General	Location specific
		1	Paint chip	1x1	Multi	Tank Both	N
		2	1	1	1	1	S
		3	1	1	1	Tank upper	N
		4	1	1	1	1	S

Relinquished by: Sold Mease Date/Time: _____

Relinquished by: _____ Date/Time: _____

Received by: ML efc 2 Date/Time: 2092023-0845

Received by: _____ Date/Time: _____

7905 7396 0358

319 E. Banbury Dr., Stockton CA 95207
(209) 451-3017

Order ID: 092303350

TWIN HARTE CSD WATER TANK #2 RECOATING & UPGRADE PROJECT
APPENDIX A - COATINGS HEAVY METALS TESTING



EMSL Analytical

464 McCormick Street, San Leandro, CA 94577
Phone/Fax: (510) 895-3675 / (510) 895-3680
<http://www.EMSL.com> sanleandrolab@emsl.com

**TWAIN HARTE CSD WATER TANK #2 RECOATING & UPGRADE PROJECT
APPENDIX A - COATINGS HEAVY METALS TESTING**

CustomerPO: 033.23
ProjectID:

Attn: **Dwayne McAllister**
Stockton Environmental
319 East Banbury Drive
Stockton, CA 95207

Phone: (209) 981-5453
Fax: (209) 451-3017
Received: 2/9/2023 08:45 AM
Collected: 2/8/2023

Project: **033.23 - 23363 MOUNTAIN DRIVE TWAIN HART 95383**

Test Report: Lead in Paint Chips by Flame AAS (SW 846 3050B/7000B)*

<i>Client Sample Description</i>	<i>Lab ID</i>	<i>Collected</i>	<i>Analyzed</i>	<i>Weight</i>	<i>Lead Concentration</i>
1	092303350-0001	2/8/2023	2/9/2023	0.1985 g	3.4 % wt
Site: PAINT CHIP - 1X1 - MULTI - TANK BOTTOM N					
2	092303350-0002	2/8/2023	2/9/2023	0.2516 g	4.5 % wt
Site: PAINT CHIP - 1X1 - MULTI - TANK BOTTOM S					
3	092303350-0003	2/8/2023	2/9/2023	0.2578 g	5.0 % wt
Site: PAINT CHIP - 1X1 - MULTI - TANK UPPER N					
4	092303350-0004	2/8/2023	2/9/2023	0.2526 g	9.4 % wt
Site: PAINT CHIP - 1X1 - MULTI - TANK UPPER S					

Cecilia Yu, Laboratory Manager
or other approved signatory

EMSL maintains liability limited to cost of analysis. Interpretation and use of test results are the responsibility of the client. This report relates only to the samples reported above, and may not be reproduced, except in full, without written approval by EMSL. EMSL bears no responsibility for sample collection activities or analytical method limitations. The report reflects the samples as received. Results are generated from the field sampling data (sampling volumes and areas, locations, etc.) provided by the client on the Chain of Custody. Samples are within quality control criteria and met method specifications unless otherwise noted.

* Analysis following Lead in Paint by EMSL SOP/Determination of Environmental Lead by FLAA. Reporting limit is 0.008% wt based on the minimum sample weight per our SOP. "<" (less than) result signifies the analyte was not detected at or above the reporting limit. Measurement of uncertainty is available upon request. Definitions of modifications are available upon request.

Samples analyzed by EMSL Analytical, Inc San Leandro, CA AIHA LAP, LLC-ELLAP Accredited #101748

Initial report from 02/09/2023 17:41:23

Appendix C

TWAIN HARTE CSD WATER TANK #2 RECOATING & UPGRADE PROJECT
APPENDIX A - COATINGS HEAVY METALS TESTING

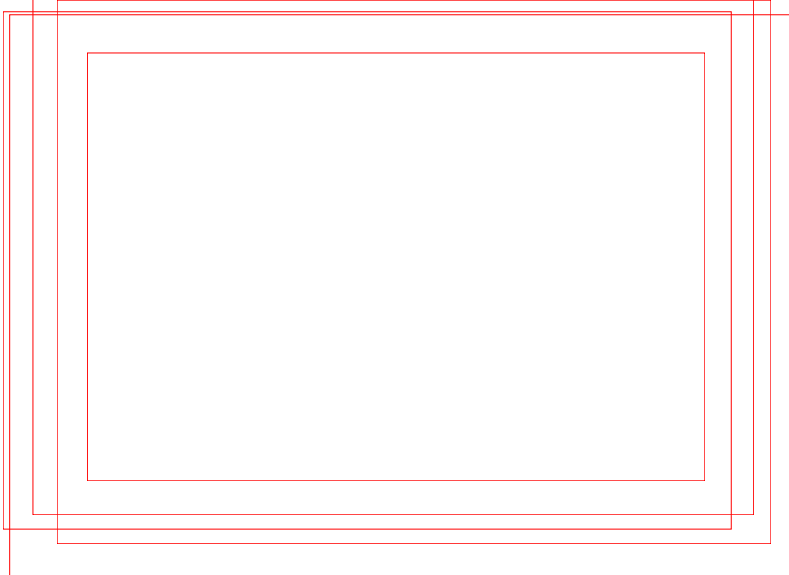
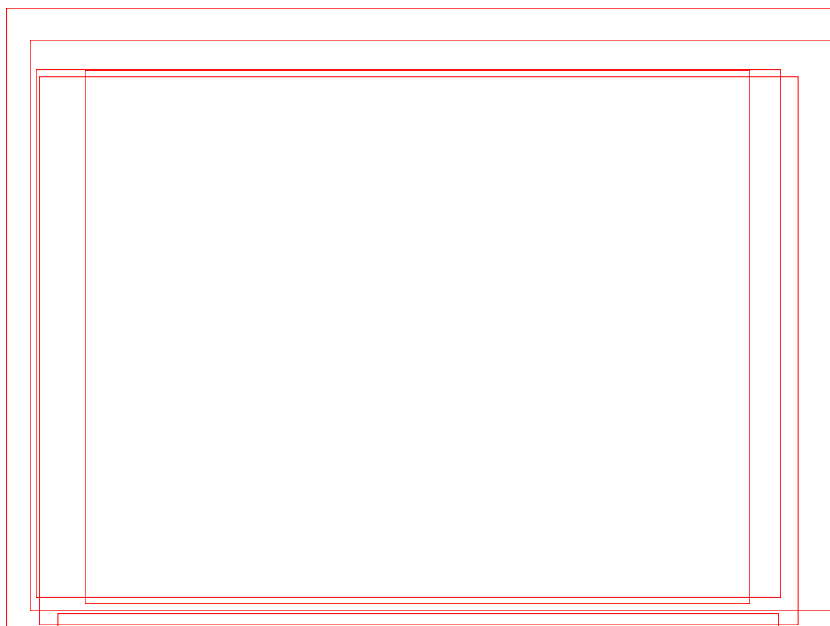

649-3331

**TWAIN HARTE CSD WATER TANK #2 RECOATING & UPGRADE PROJECT
APPENDIX A - COATINGS HEAVY METALS TESTING**

APPENDIX C
Dive Inspection Report – Existing Welded Tank

**INSPECTION REPORT FOR THE
TWIN HARTE COMMUNITY SERVICE DISTRICT'S
MILLION GALLON TANK #2
DECEMBER 29TH, 2017**



ADVANTAGE TECHNICAL SERVICES, Inc.

Specialty Engineering & Inspection Company

(805)595-2282

**INSPECTION REPORT FOR THE
TWIN HARTE COMMUNITY SERVICE DISTRICT'S
MILLION GALLON TANK #2**

DECEMBER 29TH, 2017

REVISION DATE: N/A

Pursuant to the California Business and Professions Code section 6735, the engineering report contained herein has been prepared by or under the direction of the following Registered Engineer:

**ADVANTAGE TECHNICAL SERVICES, INC.
6661 FERN CANYON LANE
SAN LUIS OBISPO, CA 93401
805-595-2282**

**UNDER THE SUPERVISION OF:
WILLIAM D. BELLIS**



Registered Civil Engineer, CA C55334



EXECUTIVE SUMMARY

Advantage Technical Services, Inc. (ATS) inspected the Twain Harte Community Services District's Million Gallon Tank #2 on November 29th, 2017. The internal and external conditions of the tank were examined in preparation for future rehabilitation work. Advantage Technical Services, Inc. (ATS) performed the inspection and evaluation.

The interior roof coatings and structural steel are in poor condition. Significant corrosion and metal loss are present on the rafters. This corrosion has reduced the strength of the roof. The corrosion has also roughened the surfaces which will make future coating more difficult.

The interior coatings below the water line are generally protecting the steel from corrosion except in scattered spots. The tank plate steel is in good condition overall but coatings are significantly aged and are beginning to fail. Adhesion testing showed a fair bond between the existing finish coat and the underlying paint so top coating the existing will have risks.

SCOPE, OBJECTIVE, AND LIMITATIONS

An inspection was completed on the interior and exterior of the welded steel potable water storage reservoir located in Twain Harte, California. Principle Inspector/Engineer, Will Bellis, P.E. and ATS associates provided the tank inspection.

ATS divers have experience and certifications that meet or exceed the requirements of AWWA C652 Standard for Disinfection of Water Storage Facilities and OSHA regulations for technical or commercial diving. Additionally, our team's certifications or licenses include a Registered Professional Engineer, API 653 Tank Inspector, AWS Certified Welding Inspector, National Association of Corrosion Engineers Level III Coating Inspector, and American Society of Nondestructive Testing Level III Engineer. With these applicable credentials, our team exceeds any other in the industry. The dive team has combined experience of over five hundred tank dive inspections.

The diver's air supply is supplied by air hoses from the surface using either a dive compressor or bottled air. The diver's air supply system offers triple redundancy; including a self-contained system maintained in the diver's possession and control. A full-time communication system supports documentation of findings and operational or emergency communications. All disinfection procedures are in accordance with the American Water Works Association Standard for Disinfection of Water-Storage Facilities (ANSI/AWWA C652-11).

The photographs provided within this report display representative views and subsequent analysis. Digital video, also included, provides additional documentation of the conditions.

The observations made during the inspection, and included in this report, provide a reasonable evaluation of the tank conditions at the time of the inspection. Considerations of safe access and reasonable care were observed in making and reporting the observations.

Latent defects or conditions found during subsequent cleaning, inspections, or other work at the tank must be brought to the Engineer's or Owner's attention.

OBSERVATIONS

General Tank Data

Type: Ground supported welded steel reservoir
Media Stored: Potable water
Diameter: 66'-0" (Measured Circumference: 207'-7")
Height: 40'-0"
Construction Date: 1976
Water level during inspection: Approximately 38'-6"

Foundation

The concrete ring footing foundation is in good condition overall. The tank may have originally been set on asphalt impregnated expansion joint material, commonly used at the time of construction, but the bottom is now resting directly on the concrete. This tank does not appear to have a thickened annular ring (as compared to tank #1).

Exterior Shell

The exterior shell coating is in fair condition. The coatings have protected the steel shell effectively from significant corrosion.

The coatings are aging and minor chalking is present. Chalking is a powdery, friable layer on the surface of a coating. It is normally caused by exposure to UV light and weathering. The degree of chalking indicates the level of erosion of the paint film.

The coatings have been reported to contain lead. Lead is hazardous and should not be disturbed by anyone other than those specifically trained and qualified to work with it. The lead however provides good corrosion protection.

There are 2-3 layers of paint (variation due to maintenance spot repairs). Coating dry film thickness was measured to range from 7-12 mils with 9 mils being the approximate average.

Exterior Roof

The exterior roof coating is in fair condition with minor chalking and some significant areas of general corrosion where the coating thickness has worn away. Corrosion covers approximately 2% of the roof area but none of the locations appear to have significant metal loss and corrosion rates in these conditions are likely to be low due to the climate.

Minor ponding conditions exist on some areas of the roof near the shell. Ponding is often found on tanks with low roof pitch or problems with tank erection. Extreme conditions could result in excessive roof loads but the primary concern on this tank is that the exterior coatings are exposed to submersion conditions. Typical exterior coating systems do not withstand submersion.

The coatings on the roof have been spot repaired so the number of layers of paint ranges from 2-3 (variation due to maintenance spot repairs). Coating dry film thickness was measured to range from 0-6 mils.

Interior Bottom

The coating on the interior bottom appears to be a “hot mop” style of coal tar. The coal tar extends up the shell. A few widely scattered corrosion nodules are present. The nodules are around ½” diameter.

Corrosion product from the roof structure and a light dusting of light brown material was present over the entire bottom. Corrosion product was most concentrated around the center of the tank. The sediment was not removed as part of this work scope. Interior spot repairs were not completed by the diver as part of this work scope.

Interior Shell

Interior shell plate is in good condition overall. Reddish colored staining is present on much of the interior shell. Coal tar extends up the shell from the bottom for about 4 inches. Epoxy coatings are protecting the remaining shell well overall. The worst area of coating failures is around the “door sheet” where scattered nodules are present along with some cracking and peeling coatings.

Several red oxide colored spot repairs are present. One is in ring 3 about 20 ft. clockwise of the shell door sheet. The other repair area is adjacent to the manway in quadrant 3. The area of each of these is approximately 4 square feet. Other repairs are smaller.

Interior Roof Plate

The interior roof plate steel is in fair condition but aging coatings have broken down and are in poor condition. Some significant metal loss can be seen along the lap joints. Staining is present over most surfaces. The staining appears to be the result of the increased permeability of the coatings. Cracking of the coating is visible in many areas.

Roof Structure

The roof is supported by a single center column with channel rafters and a round tubular center column. The base plate is the welded type. The most serious corrosion problems are above the water line.

The coatings and structure itself are in poor condition above the water line. Significant metal loss is present due to the corrosion. Corrosion is most concentrated near the roof vent at the center of the tank. It is estimated that the metal loss has progressed enough to cause severe roughening on the tops of the rafter flanges and sharp edges on the flanges themselves. Both of these conditions will make future preparation and coating less effective and more difficult.

Several sets of bolts are missing at the rafter to center support connections.

Cathodic Protection System

The elements of the sacrificial anode cathodic protection system appeared to be intact but the system is reported as being non-operable. The reference cell(s) appeared to be in normal operating condition.

Appurtenances

Level Gage: Gage board brackets, roof hardware and float all appear to be in fair to good condition and the gage appears to be operational.

Exterior Ladder and Cage: This area is in good condition overall. Adequate clearance is provided to the tank shell. There is no ladder below the mid platform.

Roof Guardrail: The guardrail is in fair condition overall but with minor scattered corrosion.

Roof Hatch: One lockable square roof hatch and one multi-bolt round opening are present. Corrosion, metal loss and roughening are present on the interior of the square hatch.

Internal Ladder: There is no internal ladder. Some brackets are present but they appear to be from a previous ladder installation.

Overflow: The visible exterior of the overflow is in good condition. The internal areas of the overflow weir were corroded and mostly uncoated.

Outlet: The outlet penetration in the tank bottom appeared to be in normal condition. Heavy interior corrosion was visible on the piping.

Sample Tap: Not accessed on exterior. Interior locations appeared to be in operable condition.

Roof Vent: The roof vent and screen are in fair condition. Significant corrosion was noted on the interior and hardware.

High Inlet: The PVC inlet piping is in good condition. The pipe is caulked at the shell penetration.

Manways: Two manways are present. The manways are in good condition overall but with minor corrosion on the interior.

RECOMMENDATIONS

The following recommendations are based on our experience as engineers and inspectors with regard to the best industry practices used by both public and private tank owners. The intent is to provide information that will likely help lower risks, optimize water quality and increase long term value for the tank owner(s). Our scope of work does not include a safety audit or evaluation but we are making recommendations where we have noted potential issues. The owner's insurance provider or safety consultant should be consulted for a review of the safety features of this facility where desired.

1. The corrosion conditions on the upper interior necessitate preparation and coating at the earliest possible time to prevent further damage from corrosion. Plan to replace most rafters due to excessive pitting, section loss, and the challenges associated with coating the rough surfaces. Have an engineering evaluation of the roof structure with consideration of snow and seismic sloshing loads to verify appropriate rafter size. Consider installation of an additional large manway or temporary door sheet during future work to improve access during coating and repair operations.
2. Exterior coatings have been effective in protecting against corrosion but they are aging and beginning to fail on the roof. Adhesion between the existing prime coat and finish coat is fair as indicated by the cross cut adhesion testing that was completed as a part of this work. Top coating the existing system would reduce preparation cost but will also increase risk of premature failure. Removal of existing spatter should be included in the coating preparation specification for future work. Containment should be provided if exterior blasting is used (assuming lead is present).
3. Consider options to repair the roof ponding or design coatings to withstand submersion during future rework.
4. The inlet is PVC. Include applicable special provisions for coating and preparation during any future painting work.
5. Cathodic protection anodes appear to be in good condition. Remove, rehabilitate and reinstall the CP system during the future coating project.
6. The exterior ladder safety climb has been painted. Check to confirm that this does not create issues with operation and rectify if appropriate. Specify no painting during future work.
7. This tank has previously been reported as having lead based coatings. Notify personnel working on this tank that lead based coatings are likely present and that the coatings shall not be disturbed without proper training and procedures. ATS took

- samples during our visit. These should be tested by a qualified lab prior to any disturbance or action that would cause release into the environment or would otherwise expose workers or the public. Testing should include heavy metals found in coatings such as lead, cadmium and chromium.
8. Provide a designated tie off point on the roof. Since only partial guardrail is present, fall protection anchorage is required. The tie off point should be engineered for fall protection pursuant to OSHA regulations. A permanent cable lanyard affixed to the roof vent may be adequate, but this system would also require an Engineer's acceptance. ATS, Inc. or other engineers familiar with tank structures and OSHA regulations can provide assistance with meeting the applicable regulations.
 9. The roof guardrail opening at the ladder is un-protected. Instruct and document training of personnel on the use of fall protection and other applicable safety procedures when working on tank roofs and other elevated locations.
 10. Consider a review of the seismic design of the tank prior to future rehabilitation work. This type of review would include updated engineering evaluations that could help lead to improving the potential for service after an earthquake. Updates include design to prevent shell failure, improved flexibility of piping connections and new recommendations for preventing roof damage from sloshing waves. ATS recommends consideration of the tank seismic use category such as post-earthquake fire suppression, post-earthquake recovery, or service to facilities that are important to the welfare of the public.
 11. Provide annual inspections of the exposed side of the tank shell to bottom connection pursuant to AWWA D100-11. Weeds, dirt, and foreign materials should be removed from this area to eliminate or reduce trapped moisture and associated corrosion.
 12. Provide inspection of the interior and exterior along with corrective maintenance at the recommended interval of every three years pursuant to AWWA D100-11 (Forward, Section III, pg. XX).



Plan view of tanks and site (courtesy of Google).

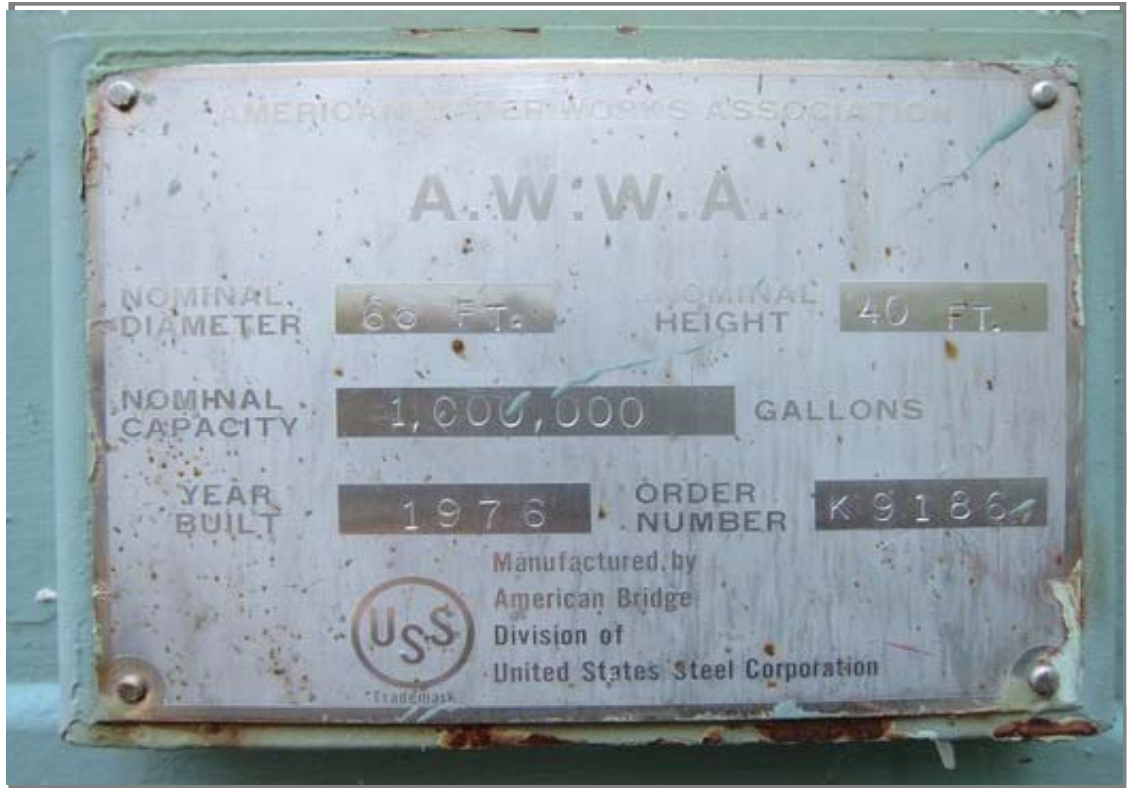

Tank name plate.



Overall view of the MG #2 Tank.



Lower shell and concrete footing. No significant corrosion points were identified.



This view of the concrete footing and lower shell shows the typical condition found.



This view represents the typical conditions on the upper shell and shell to roof joint. The upper shell is in good condition with only minor corrosion points noted.



Welds on the exterior shell are generally smoother than the older tank #1 because the welds on this tank are mostly by a mechanized system. Some scattered spatter is present particularly in the areas of welded repairs completed manually.



This view indicates the overall condition of the roof. The roof plate (steel) is in good condition but coatings are in poor condition.



Close view of a ponding area with corrosion. Submersed exterior coatings pose a maintenance challenge.



The photo above shows the roof hatch area with guardrail. A second hatch is visible in the foreground.



This view from the ground shows the platform, exterior ladder and cage. No significant corrosion is present. The climber safety rail has been painted.



The roof vent consists of a steel cover over a steel riser pipe.



This view of the underside of the vent hood shows that the screen is in good condition. Corrosion is present on the riser but the screen appeared to be bug proof.

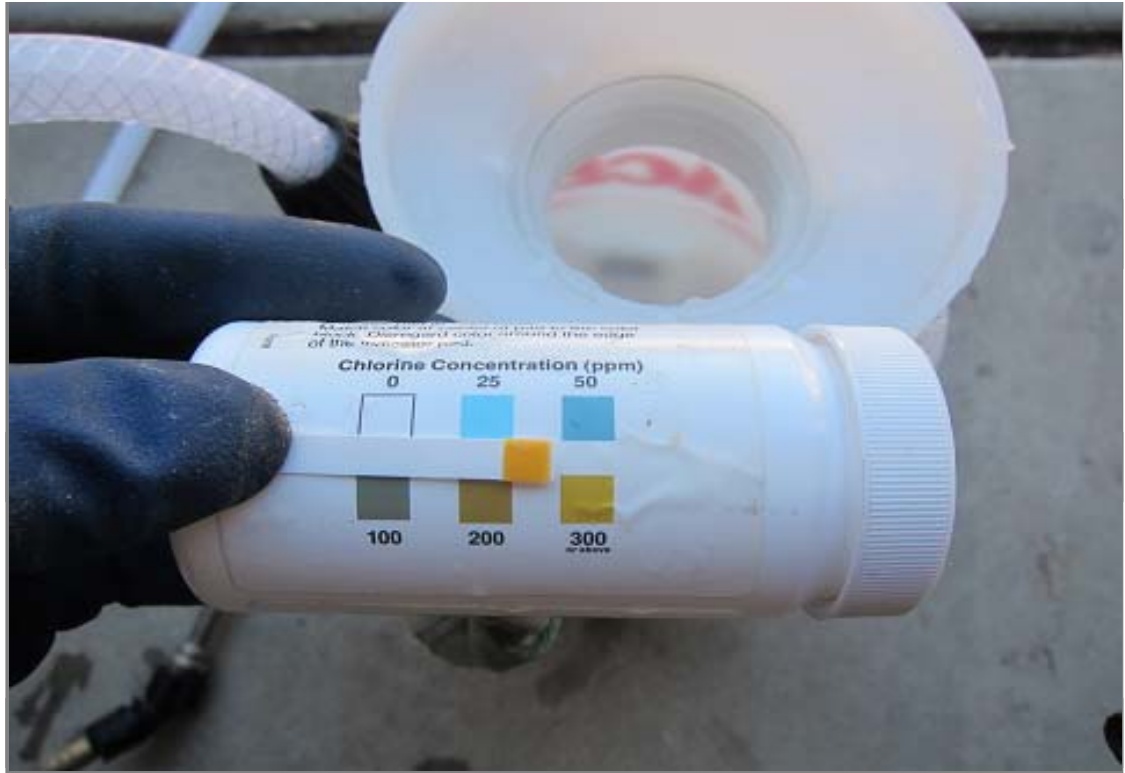

The disinfecting solution is tested to verify that it exceeds the 200 ppm free chlorine concentration level.



Diver and equipment are disinfected with the chlorine solution just prior to entry. This procedure is pursuant to AWWA disinfection standards for potable water diving.



Upper shell, rafter and adjacent roof. Coatings are peeling and general corrosion is present on many surfaces.

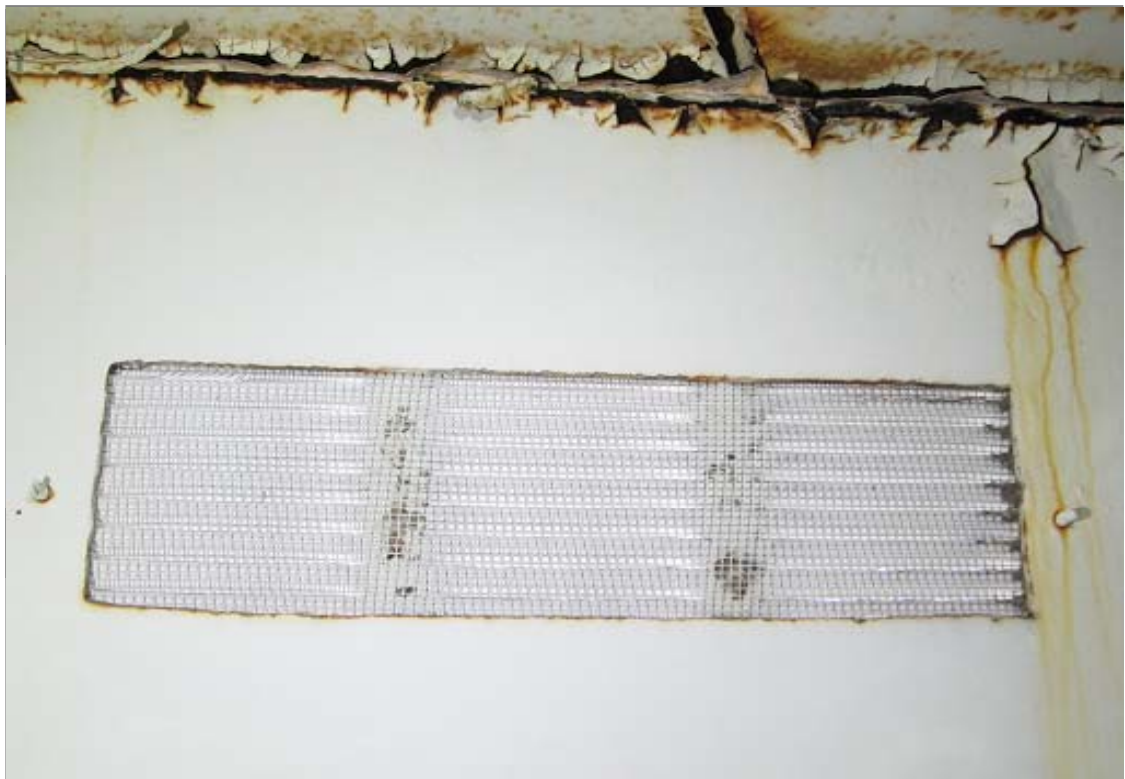

This is a close view of the upper shell showing one of the numerous shell vents.

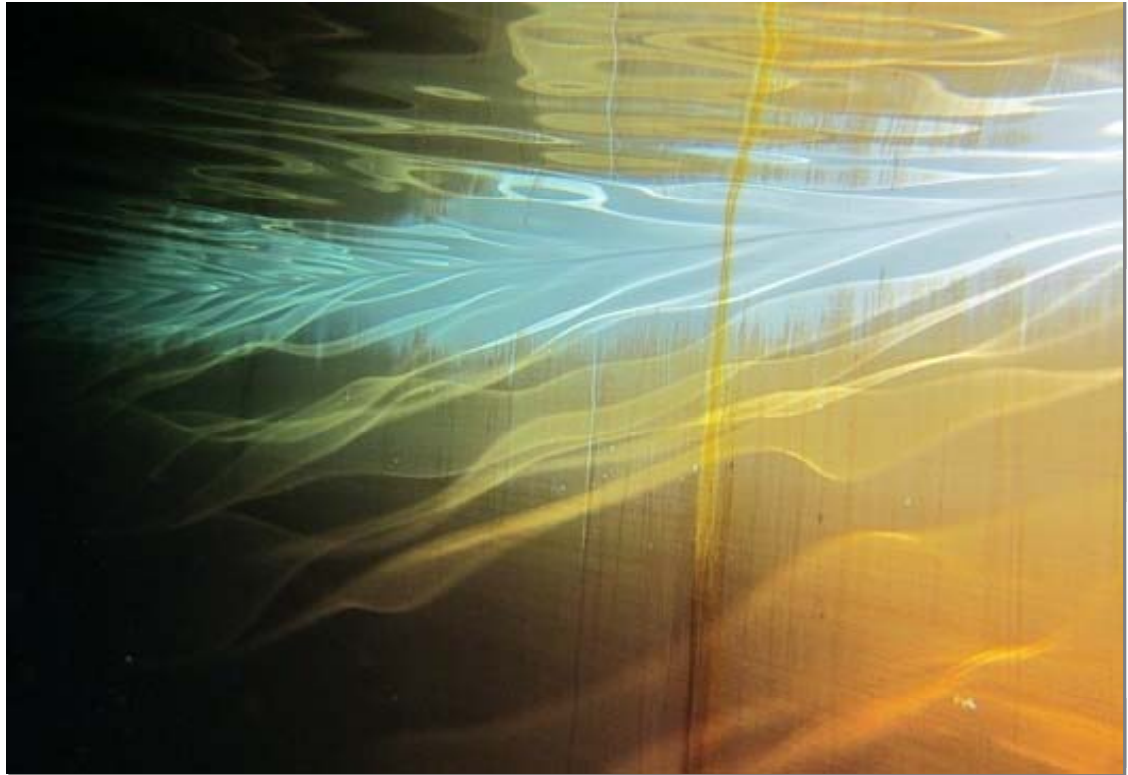

The photo above shows the interior shell just below the water surface (submersion zone). The rust color on the shell is staining.



Interior shell in the submersion zone. This view shows a junction between a horizontal and vertical shell joint. The interior shell steel appears to be in good condition overall.



Interior shell in the submersion zone near the manway in quadrant 1. The coatings are cracking and corrosion is present.



This view of cracked coatings is where a shell opening (door sheet) was cut and re-welded upon completion of the work. This area has a particularly high concentration of coating failures.



Lower shell and tank bottom. Coatings are in fair condition overall in this zone.



This photo shows an area of the lower shell where coatings are failing. This is an example of the worst condition in this zone.

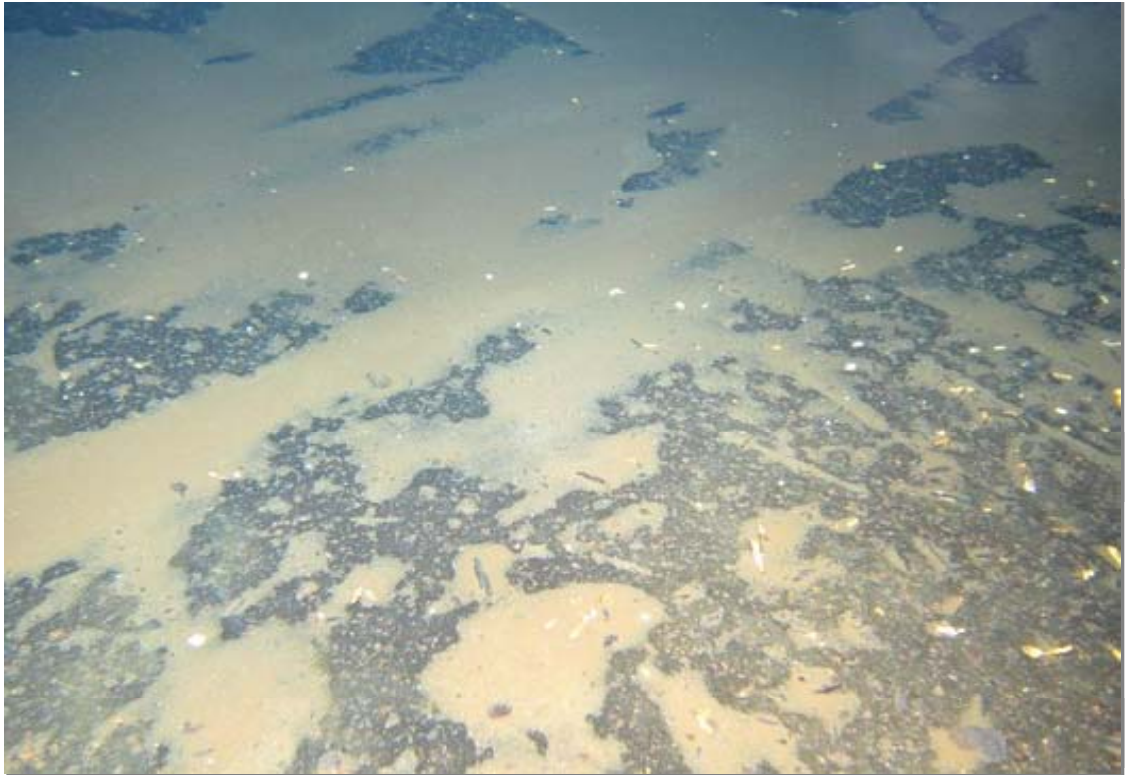

This photo shows the typical condition of the bottom. Sediment removal was not completed with this inspection.

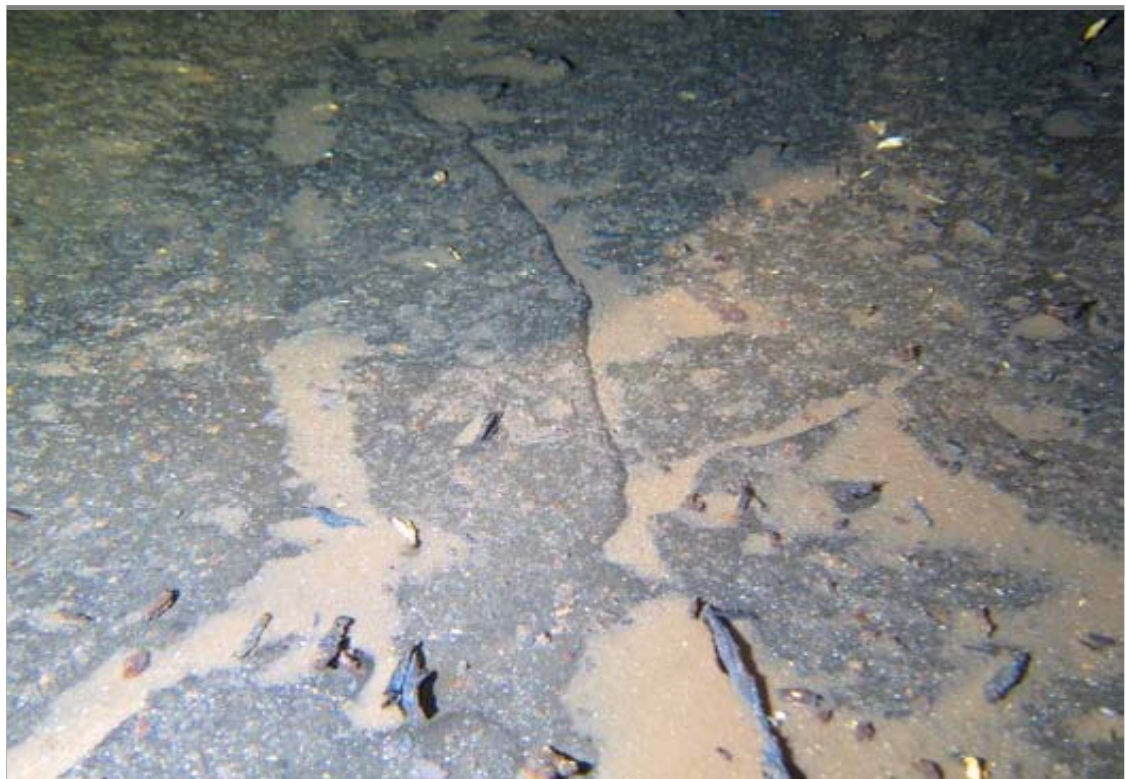

This additional view of the bottom shows some of the corrosion product from the rusting roof rafters above.



Additional view of interior bottom with coating chip from a roof rafter.



Bottom at the center support.



This view shows the column base plate and adjacent bottom plate. Coatings are in poor condition overall on the column and base plate.

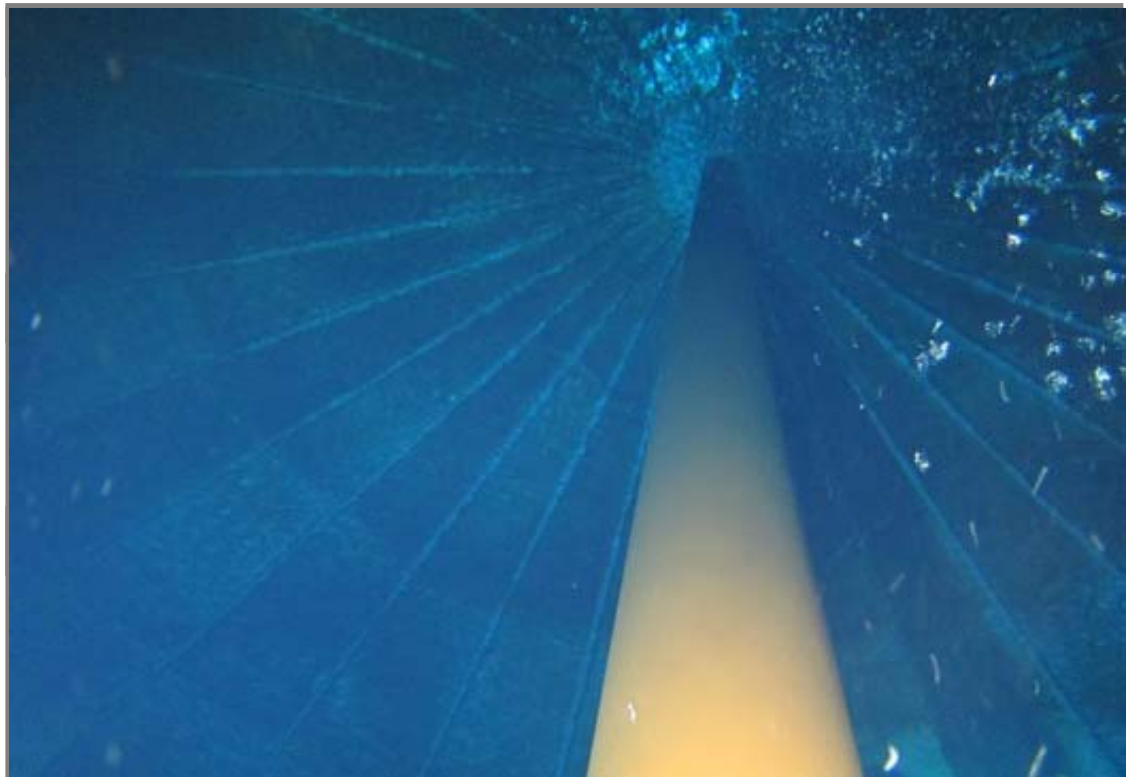

This shot was taken looking upward at the center column. The column is in good condition overall.



Upper center column, rafters and roof plate. Significant corrosion and associated metal loss are present.

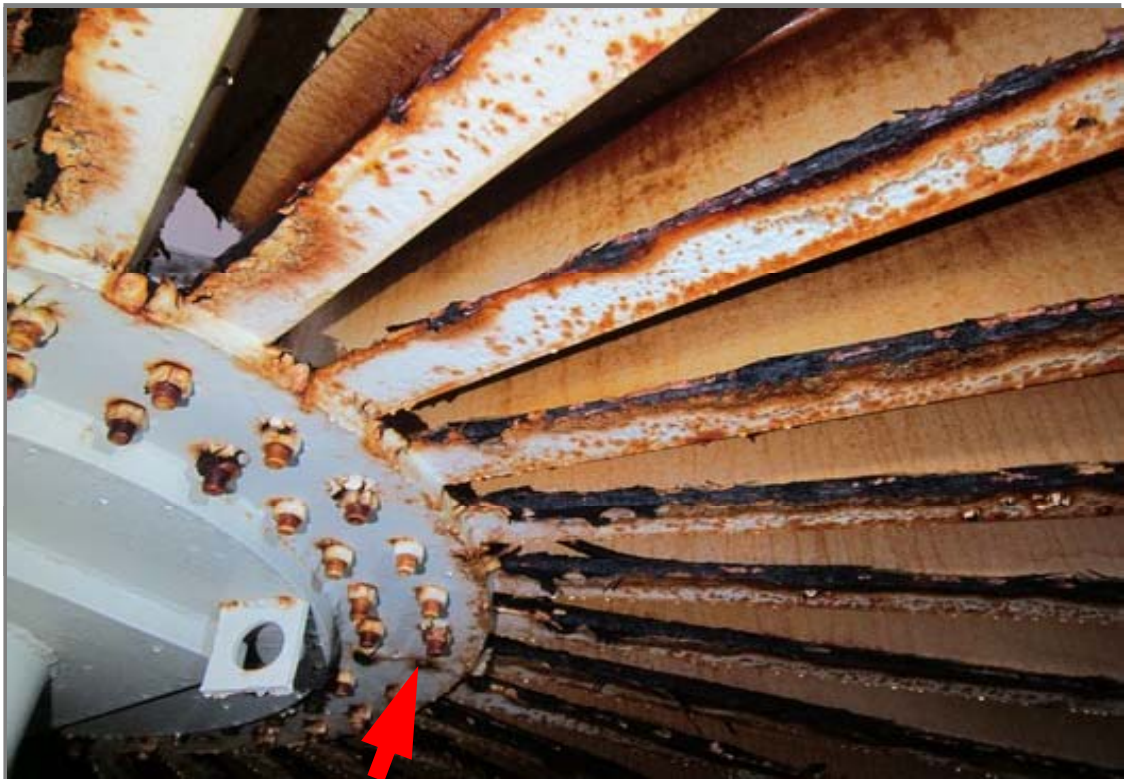

Close view of the center support and rafters. Coating failure and associated corrosion are visible. Several sets of bolts are also missing one of which is shown at the arrow.

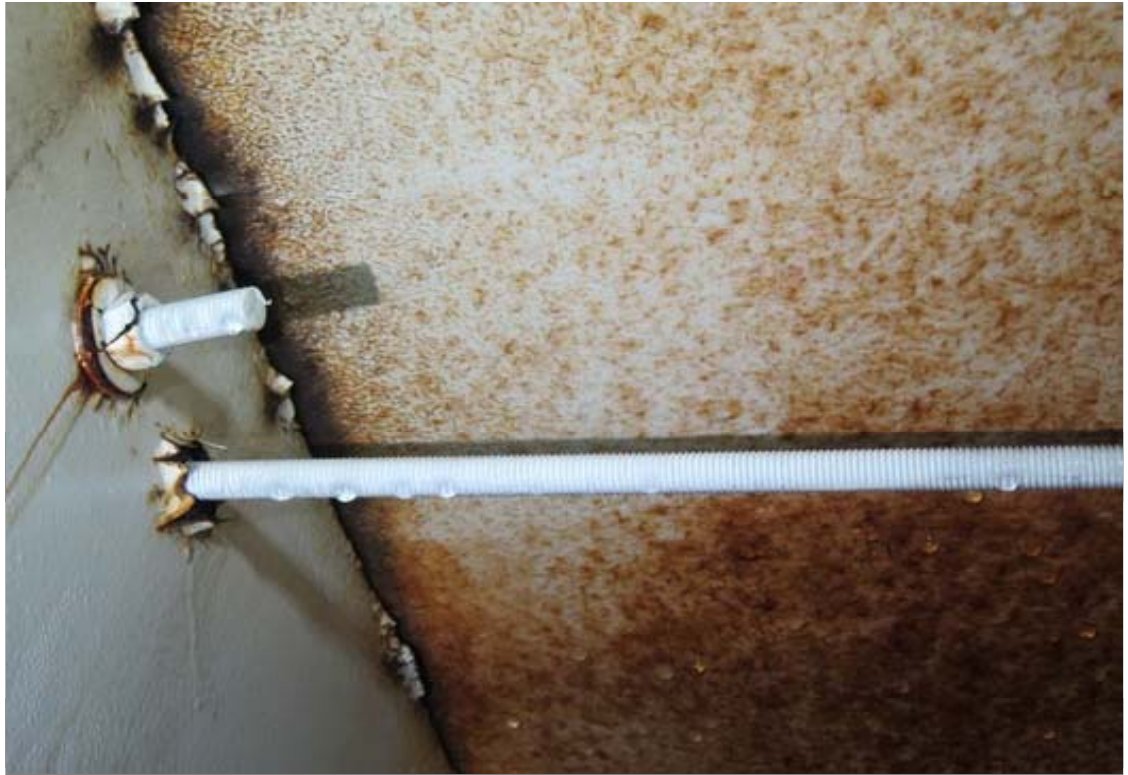

Rafter bracing at the connection to the web of a channel rafter on the interior roof.



A typical rafter with serious metal loss due to corrosion on the flanges.



This broad view of the roof is looking toward the roof hatch from near the center.

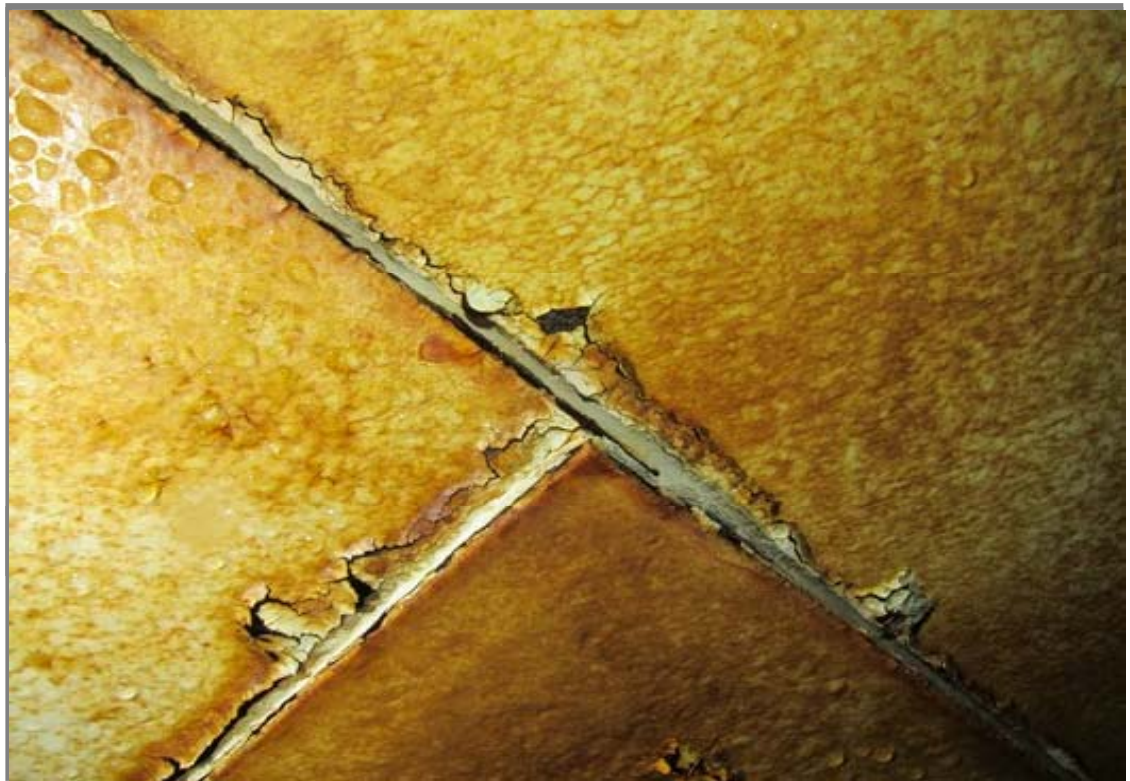

Interior roof plate lap. This view shows the concentrated corrosion that is present at lap joints along with the general corrosion on the plate.



View of the roof hatch from the interior. The diver's entry ladder is visible.



Corrosion on the interior side of the roof hatch.



Interior of the overflow weir.

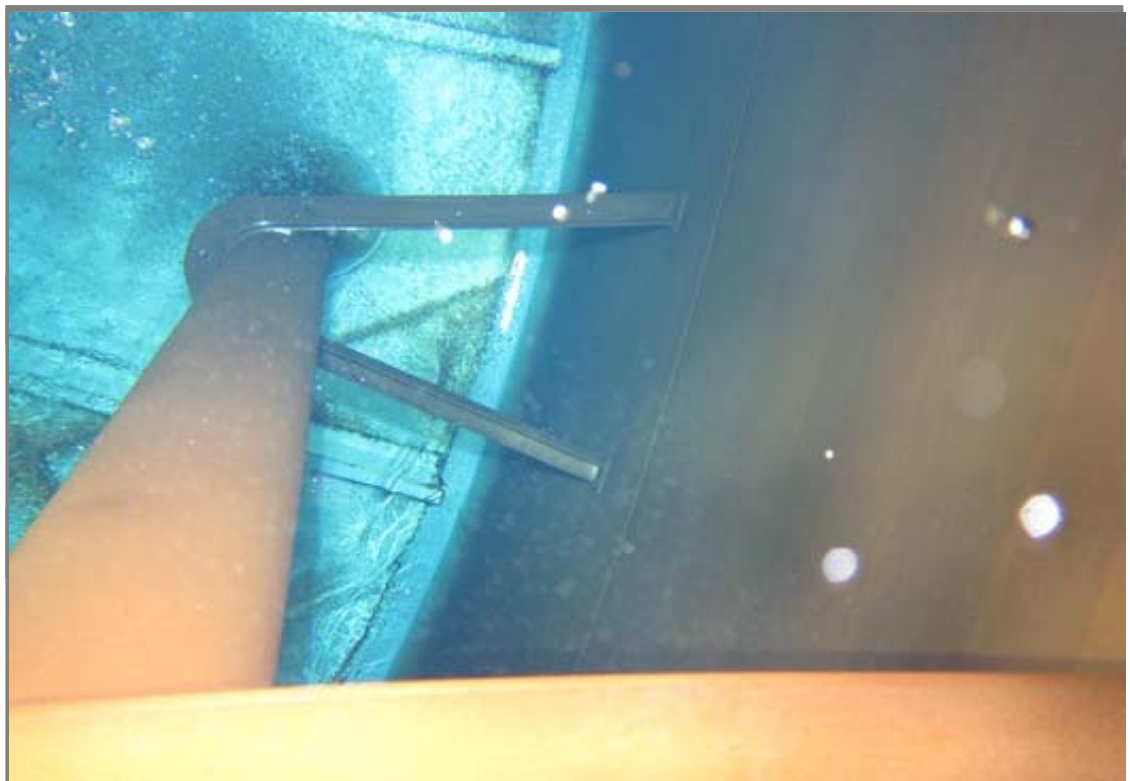

Overflow riser pipe looking upward.



The drain is located approximately 4 ft. from the shell.



An additional view showing the interior of the drain.



Interior bottom with the outlet penetration.



Corrosion nodules on the interior of the outlet pipe.



Interior view of the shell manway near quadrant 3. A spot repair is visible to the right and some significant corrosion is present below the manway.

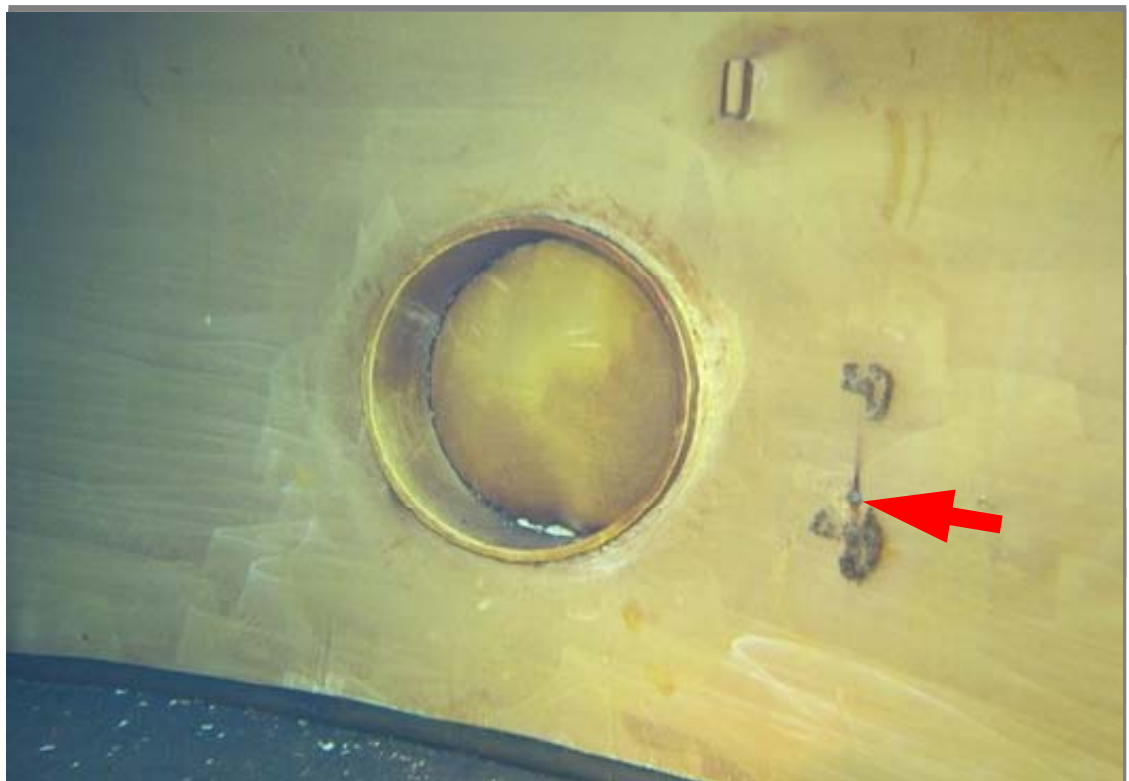

Shell manway in quadrant 1 as viewed from the interior. The spots shown at the right are areas of significant corrosion with a 3/4" diameter nodule at the arrow.



These cathodic protection system reference cells are located below the roof hatch.



Typical view of a cathodic protection hand hole cover in good condition as viewed from the exterior roof.



Adhesion was evaluated with a cross cut tape test and found to be 2A-3A.
This location was on the exterior roof.



Adhesion was evaluated with a cross cut tape test and found to be 2A-3A.
This location was on the exterior shell at the mid platform.



Chalking was evaluated pursuant to ASTM D4214, test method A. Chalking is approximately a No. 7 valuation as compared to photographic reference standard No. 1



Scattered areas of spatter are present on the shell and roof welds. The area shown above is a repair completed manually. The weld on the left is by a mechanized system.

APPENDIX D

PROJECT LOCATION & EXISTING CONDITIONS



Project site location. 23363 Mountain Dr., Twain Harte, Ca
GPS Coordinates: 38.045823°N, -120.228031°W

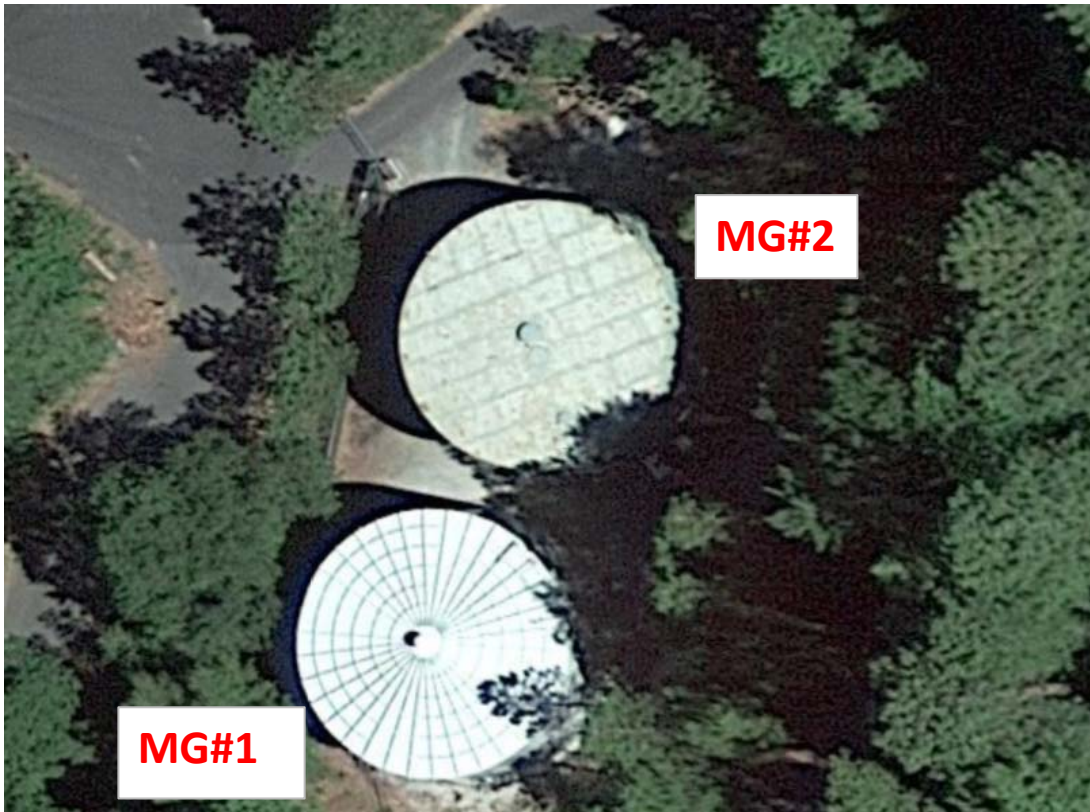

Plan view of site. MG#2 is the tank being rehabilitated in this project. MG#1 was previously rehabilitated.

TITLE: PROJECT SITE LOCATION

PROJECT: MG#2 WATER TANK RECOATING AND UPGRADE PROJECT

DATE: 12/2/22

Appendix D-1



View of interior roof of previously rehabilitated MG#1 showing the desired style of structure on the MG#2 replacement roof.



View of exterior roof of previously rehabilitated MG#1. The new roof, vent and guardrail on this MG#2 Rehabilitation project is to be similar.

TITLE: DESIRED DESIGN DETAILS FOR MG#2

PROJECT: MG#2 WATER TANK RECOATING AND UPGRADE PROJECT

DATE: 11/8/22

Appendix D-2



Desired roof configuration of new guardrail, and hatch at existing exterior ladder as seen on previously rehabilitated Tank #1.



Signage required on new roof hatch.

TITLE: DESIRED DESIGN DETAILS FOR MG#2

PROJECT: MG#2 WATER TANK RECOATING AND UPGRADE PROJECT

DATE: 11/8/22



Interior shell at top corner of previous temporary shell opening ("door sheet").



MG#2 Existing roof hatch, guardrail and appurtenances.

Modify guardrail as appropriate for attachment of the new lower ladder and cage.



PVC high inlet

Verify dimensions and provide new platform grating.

MG#2 Existing ladder platform. A new low section of ladder to the platform and appropriate additional guardrail and new grating on the platform are part of the scope of work.



Extent of roof replacement at shell

MG#2 existing rafter and shell clip and extent of roof replacement at the shell.

TITLE: EXISTING CONDITIONS MG#2

PROJECT: MG#2 WATER TANK RECOATING AND UPGRADE PROJECT

DATE: 11/8/22



MG #2 existing roof plate, interior center support and rafters to be replaced.

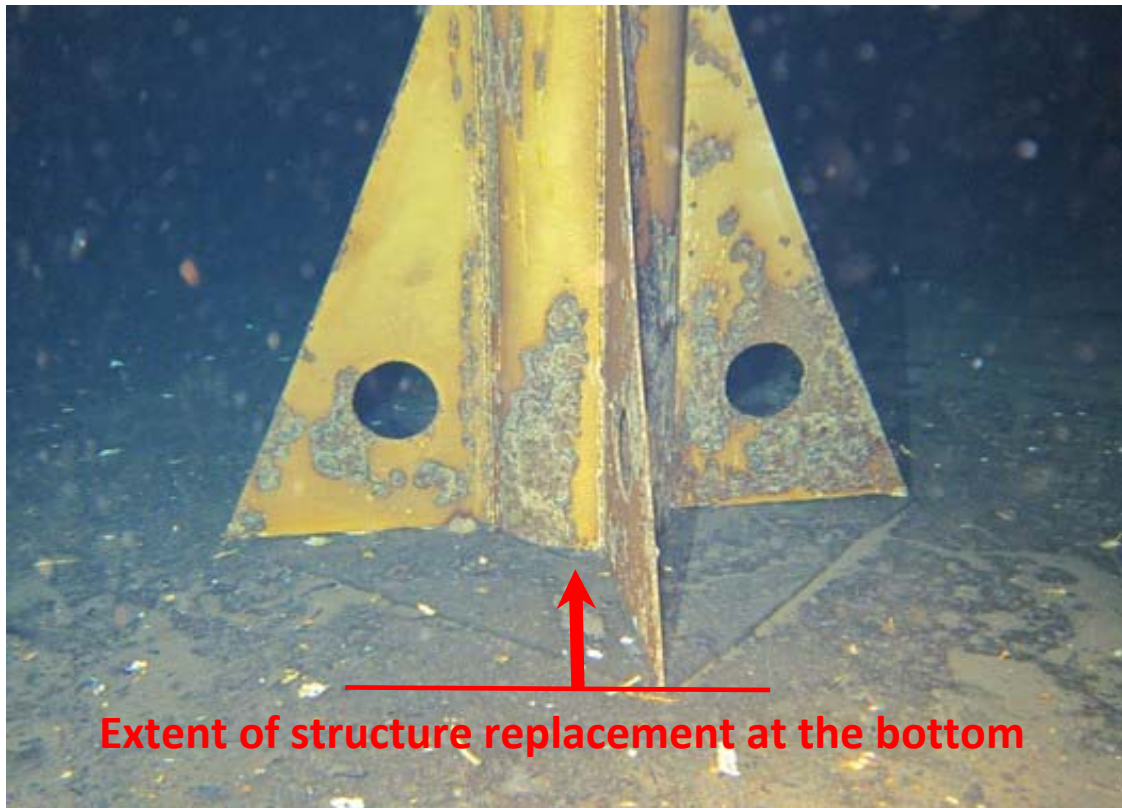

Extent of structure replacement at the bottom

Existing MG#2 center column base plate and extent of roof structure replacement at the bottom.



Acceptable support for PVC high inlet as shown on MG tank #1.



Existing PVC in high inlet pipe on MG#2 that will require protection during work and support from the new roof.

TITLE: INLET SUPPORT

PROJECT: MG#2 WATER TANK RECOATING AND UPGRADE PROJECT

DATE: 12/2/22

Appendix D-7

Quantity of shell vents required for bid sheet. No other patch plates expected but option will be left open to use bid pricing if other areas need patching.



View of acceptable shell vent closure.



View of typical existing shell vent. Cover plates are to be installed as part of the Work.

TITLE: SHELL VENT

PROJECT: MG#2 WATER TANK RECOATING AND UPGRADE PROJECT

DATE: 12/2/22

Appendix D-8



Board Meeting Agenda Item Summary

March 21, 2022

ITEM #:	05B	ITEM TYPE:	<input type="checkbox"/> Discussion <input type="checkbox"/> Action <input checked="" type="checkbox"/> Both
SUBJECT:	Discussion/action to approve a Participation Agreement for the Sourcewell Cooperative Purchasing Program.		
RELATION TO STRATEGIC PLAN:	<input checked="" type="checkbox"/> N/A <input type="checkbox"/> Advances Goal/Objective #'s: _____		

RECOMMENDED ACTION:

Approve the Sourcewell Cooperative Purchasing Program Participation Agreement.

SUMMARY:

District Policy #3040 (Purchasing and Expense Authorization) and California Public Contract Code (PCC) set forth competitive bidding requirements that the District must follow when procuring materials and equipment and letting contracts for construction. Preparing documents for competitive bidding and performing required competitive bidding tasks is both time-consuming and costly.

California Government Code Section 6502 enables governing boards to enter into agreements with other public agencies to jointly exercise shared powers, including procurement of materials and services. Sourcewell is a public agency dedicated to serving other public agencies by performing cooperative purchasing. The agency lets contracts for a variety of materials and services per the competitive bidding requirements of the law. Public agencies who have entered into participation agreements with Sourcewell have access to these publicly bid and awarded contracts, saving participating agencies time and money when procuring materials and services.

District Policy #3040 authorizes the District to utilize government cooperative purchasing programs. Entering into a Participation Agreement with Sourcewell is in the best interest of the District and its customers.

FINANCIAL IMPACT:

This action has no immediate financial impact, but will save the District money by enabling it to procure materials and equipment that has already been publicly and competitively bid by Sourcewell.

ATTACHMENTS:

- Sourcewell Cooperative Purchasing Program Participation Agreement

Sourcewell Cooperative Purchasing Program Participation Agreement

This Participation Agreement is between Sourcewell and Participating Entity to provide access to Sourcewell's Cooperative Purchasing Program. Sourcewell's Board of Directors has approved these terms and conditions through operation of this intergovernmental Participation Agreement. Participating Entity approves this Agreement upon registration with Sourcewell.

Section 1: Authority

1.1 Sourcewell is a service cooperative established by Minn. Stat. § 123A.21 as a local unit of government pursuant to the Minn. Const. art. XII, sec. 3.

1.2 Sourcewell is authorized to provide a Cooperative Purchasing Program by Minn. Stat. § 123A.21, subd. 7(23) to Participating Entities.

1.3 Sourcewell's cooperative purchasing contracts and master agreements are offered through Minn. Stat. § 471.59 and this Participation Agreement. The Sourcewell Board of Directors has approved these participation terms, and Sourcewell is authorized to enter this interlocal or joint powers agreement with an eligible Participating Entity through this Participation Agreement.

1.4 Participation in Sourcewell's Cooperative Purchasing Program is open to eligible Participating Entities. A Participating Entity is any eligible entity registering with Sourcewell, including: any government unit, including a state, city, county, town, village, school district, political subdivision of any state, federally recognized Indian tribe, any agency of the United States, any instrumentality of a governmental unit, any other entity as defined in Minn. Stat. § 471.59 Subd. 1(b), and any entity as defined in Art. VI of the Sourcewell Bylaws.

1.5 Participating Entity and Sourcewell agree this Participation Agreement is for the purpose of allowing access to available Sourcewell Cooperative Purchasing Program contracts and master agreements with awarded suppliers.

1.6 Participating Entity represents, through an authorized signatory, it is eligible for participation as defined in this Agreement.

Section 2: General Terms

2.1 Sourcewell will make its Cooperative Purchasing Program available to Participating Entity. Sourcewell programs and master agreements are provided to Participating Entity "as is." Sourcewell makes no representation as to warranties of quality, merchantability, or fitness for a particular purpose. Participation in the Program is voluntary and non-exclusive.

2.2 To purchase from Sourcewell contracts and master agreements, Participating Entity must enter into a purchase order or other subsequent agreement in accordance with the terms and conditions of master agreements directly with a supplier. Participating Entity will be responsible

for all aspects of its purchase, including ordering its goods and services, inspecting, accepting the goods and services, and prompt payment to supplier who will have directly billed the Participating Entity.

2.3 The Parties to this Agreement will adhere to all applicable laws concerning the procurement of goods and services in its respective jurisdiction.

2.4 Access to the Cooperative Purchasing Program is effective upon the date of Participating Entity’s completed registration. The Agreement will remain in effect until canceled by either party upon thirty (30) days written notice to the other party.

2.5 Each party agrees that it is responsible for its acts and the results thereof, to the extent authorized by law, and will not be responsible for the acts of the other party and the results thereof.

2.8 There will be no financial remunerations by or obligations upon Participating Entity for participation in Sourcewell Cooperative Purchasing Program.

2.9 Sourcewell’s Cooperative Purchasing Program master agreements will be procured in compliance with Minnesota law and the Sourcewell Cooperative Purchasing Program.

2.10 The records and documents related to this this Agreement are subject to the Minnesota Data Practices Act, Minnesota Statutes Chapter 13.

Section 3: Approval

The Sourcewell Board of Director has approved this Policy effective July 1, 2022.

Sourcewell:

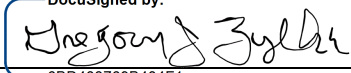
DocuSigned by:
By 
Authorized Signature – Signed

By Greg Zylka
Name – Printed
Title Sourcewell Board of Directors Chair
Date 8/19/2022 | 9:40 AM CDT

DocuSigned by:
By 
Authorized Signature – Signed

By Sara Nagel
Name – Printed
Title Sourcewell Board of Directors Clerk
Date 8/19/2022 | 10:35 AM CDT

Participating Entity:

By _____
Authorized Signature – Signed

By _____
Name – Printed
Title _____
Date _____

Organization Information

Indicate an address to which correspondence may be delivered.

Organization Name* _____

Address* _____

City* _____

State Code* _____ Zip Code* _____

Country* _____

Employer Identification Number _____

Website _____

Contact person* (First, Last) _____

Job Title* _____

Email completed agreement to:
service@sourcewell-mn.gov

You may also mail the completed agreement to:

Sourcewell
 202 12th Street NE
 P.O. Box 219
 Staples, MN 56479

Job Role

- Administrator
- Department Head
- Department Purchaser
- Human Resources
- Procurement Officer
- Teacher
- Other

Department

- Administration
- Dining/Food Service
- Facilities/Operations
- Fleet/Transportation
- Human Resources
- Information Technology
- Parks, Recreation & Athletics
- Public Safety/Security
- Public Works/Utilities
- Purchasing & Finance

Email* _____

Phone* _____

Organization Type:

Government

- County
- Federal
- Municipality
- Province/Territory
- Special District
- State
- Township
- Tribal

Education

- Local Education Agency (Public K-12 and Pre-K)
- Private Local Education Agency (Private K-12)
- Private Higher Education
- Public Higher Education

Nonprofit

Documentation demonstrating nonprofit status is required when submitting application.

- Church
- Medical Facility
- Other

Referred by

- Advertisement
- Colleague/Friend
- Conference/Trade Show _____
- Supplier
- Search Engine/Web Search
- Sourcewell Employee

**Denotes required information*



Board Meeting Agenda Item Summary

March 21, 2022

ITEM #:	05C	ITEM TYPE:	<input type="checkbox"/> Discussion <input type="checkbox"/> Action <input checked="" type="checkbox"/> Both
SUBJECT:	Discussion/action to adopt Resolution #23-07 – Approving a Fiscal Year 2022-23 Sewer Fund Budget Adjustment in the Amount of \$10,000 for Lift Station Pump Repair.		
RELATION TO STRATEGIC PLAN:	<input checked="" type="checkbox"/> N/A <input type="checkbox"/> Advances Goal/Objective #'s: _____		

RECOMMENDED ACTION:

Adopt Resolution #23-07 – Approving a Fiscal Year (FY) 2022-23 Sewer Fund Budget Adjustment in the Amount of \$10,000 for Lift Station Pump Repair.

SUMMARY:

The District currently owns and operates three sewer lift stations – Mark Twain, Redwing, and Shadybrook. The lift stations are used to pump wastewater from low points in the District (where wastewater cannot drain by gravity) to higher locations in the District’s gravity-powered wastewater collections system.

All of the District’s sewer lift stations are equipped with two pumps. One pump operates as the main pump and the other pump serves as a backup to prevent a sewer overflow if the main pump fails. The Mark Twain and Shadybrook Lift Stations recently experienced the failure of their main pumps. Both pumps require a complete rebuild to restore them to operation and ensure the redundancy needed to prevent a lift station overflow. The estimated cost to rebuild the pumps is \$11,500.

Although the District’s FY 2022-23 Sewer Fund Budget provides for expenses to cover lift station maintenance and repair, it is not sufficient to rebuild the pumps.

FINANCIAL IMPACT:

This action increases the transfer from Sewer Fund Capital Reserves by \$10,000, leaving an estimated Capital Reserves balance of \$709,185.

ATTACHMENTS:

- Resolution #23-07 – Approving a Fiscal Year 2022-23 Sewer Fund Budget Adjustment in the Amount of \$10,000 for Lift Station Pump Repair

**TWAIN HARTE COMMUNITY SERVICES DISTRICT
RESOLUTION NO. 23-07**

**APPROVING A FISCAL YEAR 2022-23 SEWER FUND BUDGET ADJUSTMENT IN
THE AMOUNT OF \$10,000 FOR LIFT STATION PUMP REPAIR**

WHEREAS, Twain Harte Community Services District (District) owns and operates the Mark Twain and Shadybrook Lift Stations, which are used to pump wastewater from low points in the District to locations in the District's wastewater collection system that flow by gravity; and

WHEREAS, said lift stations are equipped with two pumps each – one lead pump and one back-up pump to provide redundancy and reduce the possibility of a sewer overflow in the event of pump failure; and

WHEREAS, one pump in both the Mark Twain and Shadybrook Lift Stations recently failed, necessitating that both pumps be rebuilt at a cost of \$11,500; and

WHEREAS, the FY 2022-23 Sewer Budget includes \$6,900 in the Facilities Maintenance & Repair – Lift Station expense line item, some of which has already been expended for repairs; and

WHEREAS, the FY 2022-23 Sewer Fund Budget must be adjusted in order to repair the Mark Twain and Lift Station pumps and restore necessary pump redundancy in both lift stations.

NOW, THEREFORE, BE IT RESOLVED, by the District Board of Directors that the FY 2022-23 Sewer Fund Budget be adjusted as follows:

1. Increase the "Facilities Maintenance & Repair – Lift Station" expense line item by \$10,000 from \$6,900 to \$16,900; and
2. Increase the Transfer from Reserves by \$10,000.

PASSED AND ADOPTED, by the Board of Directors of Twain Harte Community Services District on March 21, 2023, by the following vote:

AYES:
NOES:
ABSENT:
ABSTAIN:

ATTEST:

Eileen Mannix, Board President

Kimberly Silva, Board Secretary