

# TWAIN HARTE MEADOWS PARK

## CLIENT

TWAIN HARTE COMMUNITY SERVICES DISTRICT  
22945 MEADOW DRIVE  
TWAIN HARTE, CA 95383

## PROJECT TEAM

### WATERSHED PROGRESSIVE

CENTRAL SIERRA OFFICE  
18653 MAIN STREET  
GROVELAND, CALIFORNIA 95321

CENTRAL COAST OFFICE  
206 N. SIGNAL ST., SUITE S  
OJAI, CA 93023

PRINCIPAL  
REGINA HIRSCH  
REGINA@H2OPROGRESSIVE.COM

PROJECT MANAGER  
SYDNEY SANTOS, P.E.  
SYDNEY@H2OPROGRESSIVE.COM

CIVIL ENGINEER  
PAIGE BRUE, P.E.  
PAIGE@H2OPROGRESSIVE.COM

PROJECT LEAD LANDSCAPE DESIGNER  
AJA BULLA-RICHARDS  
AJA@H2OPROGRESSIVE.COM

THE FOLLOWING IS A GENERAL LIST OF BIDDABLE ITEMS FOR THIS PROJECT (SEE SPECIFICATIONS FOR A MORE DETAILED DESCRIPTION OF EACH BIDDABLE ITEM):

- GENERAL SITE WORK (TREE PROTECTION, TEMPORARY FENCING IF DEEMED NECESSARY FOR SECURITY, CLEANUP, AND STORM DRAIN PROTECTION).
- DEMOLITION, REMOVAL, AND LEGAL DISPOSAL OF ASPHALT, A PORTION OF THE POOL, ABANDONED PIPES, AND OTHER UNUSABLE DEBRIS ON SITE.
- EARTHWORK (INCLUDES EXCAVATION FOR TANK-3) AND REMOVAL OF ALL ROCKS GREATER THAN 6 INCHES FROM BACKFILL.
- BOULDER, COBBLE, AND ROCK MULCH PLACEMENT (FIELD DIRECTED BY OWNER'S REPRESENTATIVE). BOULDER SELECTION WILL ALSO BE DIRECTED BY OWNER'S REPRESENTATIVE.
- PERMEABLE PATHWAY (INCLUDES PEDESTRIAN BOARDWALKS).
- PERMEABLE PARKING LOT.
- CURB AND CURB RAMP INSTALLATION.
- STREET LIGHT INSTALLATION.
- PREFABRICATED RESTROOM PREPARATION AND COORDINATION.
- PAVILION (INCLUDING GT-1)
- ELECTRICAL WORK.
- UNDERGROUND UTILITIES (SANITARY SEWER AND WATER).
- OTHER UNDERGROUND UTILITIES (IRRIGATION, RAINWATER CONVEYANCE, AND STORM DRAINS).
- TOWN CHRISTMAS TREE INSTALLATION.
- PADS AND SETTING OF SIX POLY TANKS (TANK-1).
- PADS AND SETTING OF ONE CORRUGATED METAL TANK (TANK-2).

NOTE: REFER TO SPECIFICATIONS FOR A MORE DETAILED DESCRIPTION OF BIDDABLE ITEMS. FOR CLARIFICATION PURPOSES, BIDDABLE ITEMS WILL BE INDICATED WITH AN ASTERISK (\*) ON THIS PLAN SET. HOWEVER, THESE MARKINGS ARE ONLY A GUIDE AND DO NOT SUPERSEDE THE MEASUREMENT AND PAYMENT SPECIFICATIONS.

THE FOLLOWING IS A GENERAL LIST OF NON-BIDDABLE/EXCLUDED ITEMS (WORK TO BE DONE BY OTHERS) SHOWN ON THESE PLANS INCLUDE:

- LANDSCAPING, PLANTING, AND MULCHING
- PREFORMED SCOUR HOLE INSTALLATION
- IRRIGATION EMITTER PLACEMENT
- RESTROOM GREYWATER PLUMBING
- GREYWATER PLANTINGS
- INSTALLATION OF ABOVEGROUND PLUMBING, VALVES, AND ACCESSORIES FOR RAIN TANKS
- RAINWATER PUMP INSTALLATION
- LOW-VOLTAGE LIGHTING (E.G., PEDESTRIAN WALKWAYS AND CHRISTMAS TREE UPLIGHT)
- PICNIC TABLE ASSEMBLY
- BARBEQUE ASSEMBLY AND INSTALLATION
- SINK AND LARGE BARBEQUE IN THE PAVILION
- EDUCATIONAL/DISCOVERY LAB SIGNAGE
- FLUME AND WATER PLAY DISCOVERY LAB
- TANK-3 INSTALLATION AND ASSOCIATED ACCESSORIES
- PARK ENTRANCE SIGN AND INSTALLATION
- PREFABRICATED RESTROOM PURCHASE, WHICH INCLUDES PLACEMENT WITH A CRANE.

## ABBREVIATIONS

(E)	EXISTING	U/S	UPSTREAM
(N)	NEW	D/S	DOWNSTREAM
LOD	LIMIT OF DISTURBANCE	INV	INVERT
POC	POINT OF CONNECTION	STD SPEC	STANDARD SPECIFICATION
VAC	AC VOLTAGE	CMP	CORRUGATED METAL PIPE
CW	COLD WATER	USFS	UNITED STATES FOREST SERVICE
RW	RAINWATER		
GW	GREYWATER		
SW	STORMWATER		
LP	LOW POINT		
HP	HIGH POINT		
RSP	ROCK SLOPE PROTECTION		
LFG	LOW FINISH GRADE		
HFG	HIGH FINISH GRADE		
TC	TOP OF CURB		
SF	SQUARE FOOT		
LF	LINEAL FOOT		
CY	CUBIC YARD		

## SHEET INDEX

L0.0	COVER SHEET
L0.1	STORMWATER BENEFITS
L1.1	EXISTING CONDITIONS SURVEY AND DEMOLITION
L1.2	DEMOLITION AND EROSION CONTROL DETAILS
L2.1	GRADING AND DRAINAGE PLAN
L2.2	GRADING AND DRAINAGE SECTIONS
L2.3	GRADING AND DRAINAGE DETAILS
L2.4	GRADING AND DRAINAGE DETAILS
L3.1	MATERIALS PLAN
L3.2	MATERIALS LAYOUT PLAN
L3.3	MATERIALS DETAILS
L3.4	MATERIALS DETAILS
L4.1	IRRIGATION PLAN
L4.2	IRRIGATION SCHEDULE NOTES
L4.3	IRRIGATION DETAILS
L5.1	PLANTING PLAN
L5.2	PLANTING SCHEDULE
L5.3	PLANTING DETAILS
L6.1	WATER REUSE AND UTILITIES PLAN
L6.1A	WATER REUSE AND UTILITIES PLAN ENLARGED
L6.2	WATER REUSE AND UTILITIES SCHEDULE
L6.3	WATER REUSE AND UTILITIES DETAILS
L6.4	WATER REUSE AND UTILITIES DETAILS
L6.5	WATER REUSE AND UTILITIES DETAILS
L6.6	WATER REUSE AND UTILITIES DETAILS
L7.1	LIGHTING AND ELECTRICAL PLAN
L7.2	LIGHTING AND ELECTRICAL NOTES
L7.3	LIGHTING AND ELECTRICAL DETAILS
L8.1	DISCOVERY LABS KEY PLAN
L9.1	AS-BUILT BOCCO COURT SITE PLAN STRUCTURAL PLANS (PAVILION) RESTROOM PLAN

## VICINITY MAP

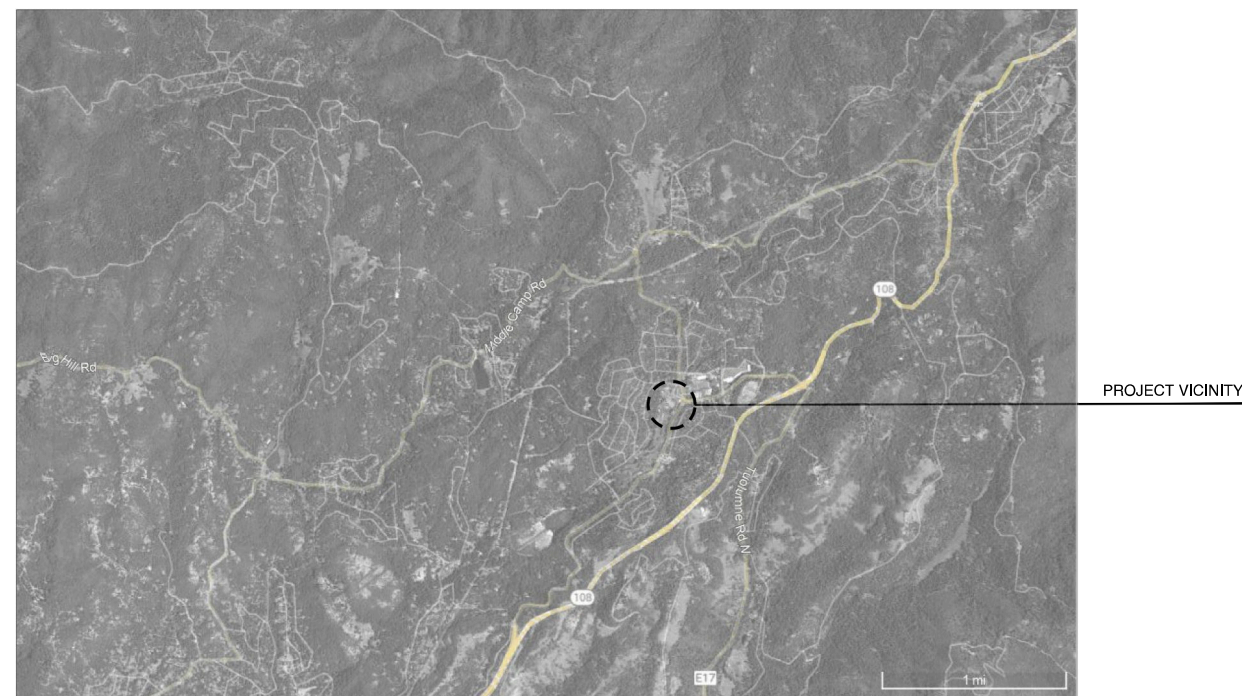

## PROJECT LOCATION MAP

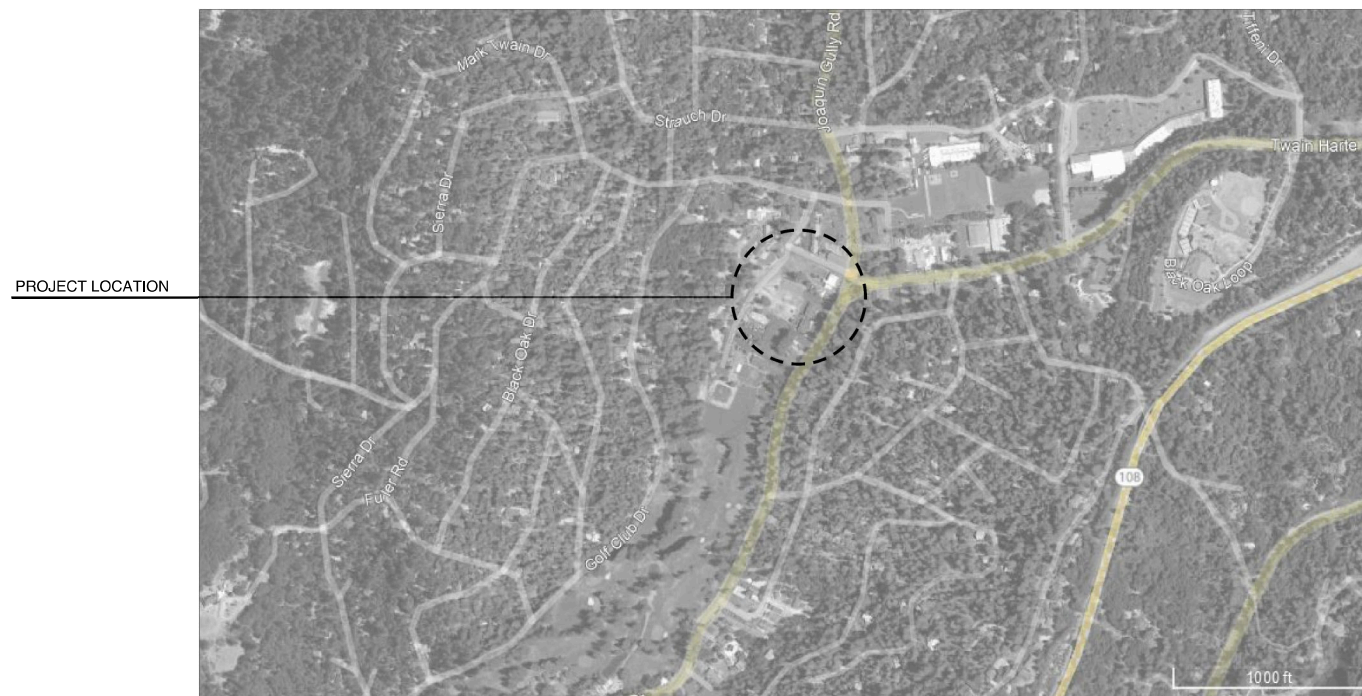

WATERSHED PROGRESSIVE  
WWW.WATERSHEDPROGRESSIVE.COM  
209.732.0018

CENTRAL SIERRA OFFICE  
18653 MAIN STREET  
GROVELAND, CALIFORNIA 95321

OJAI OFFICE  
206 N. SIGNAL ST., SUITE S  
OJAI, CALIFORNIA 93023



Twain Harte Meadows  
22945 Meadow Drive, Twain Harte, CA 95383

REVISION	DATE
1 60% DRAFT TO CSD	05.31.22
2 60% TO CSD	06.15.22
3 60% TO SWB	07.28.22
4 100% TO CSD	12.14.22
5 100% TO CSD	04.28.23
6 100% TO CSD	06.07.23

DESIGN BY: MS,JS  
DRAWN BY: MS,JS  
REVIEW BY: JPB, RH, NS

© 2023 Watershed Progressive. The design ideas and plans represented by these documents are the property of Watershed Progressive. Use or copy is permitted by contract only. The use or revision of these ideas or plans is prohibited without the written permission of Watershed Progressive.

## COVERSHEET

# L0.0

100% CD

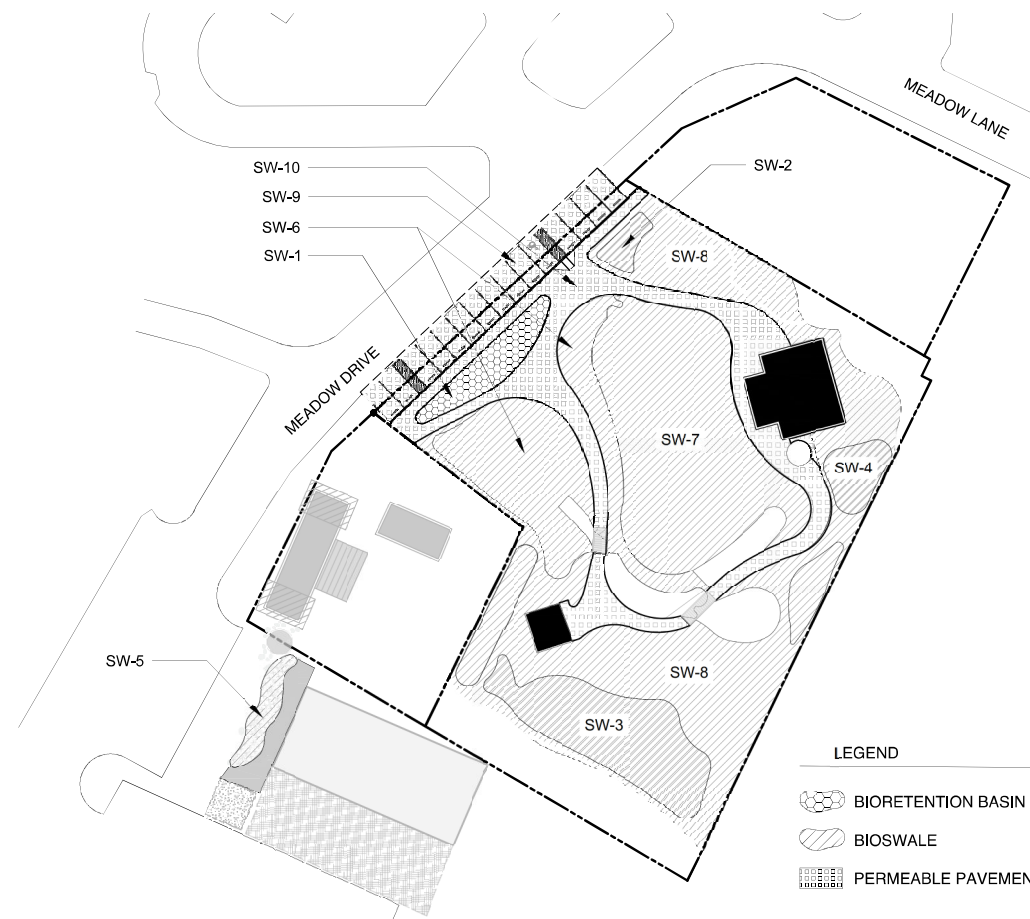
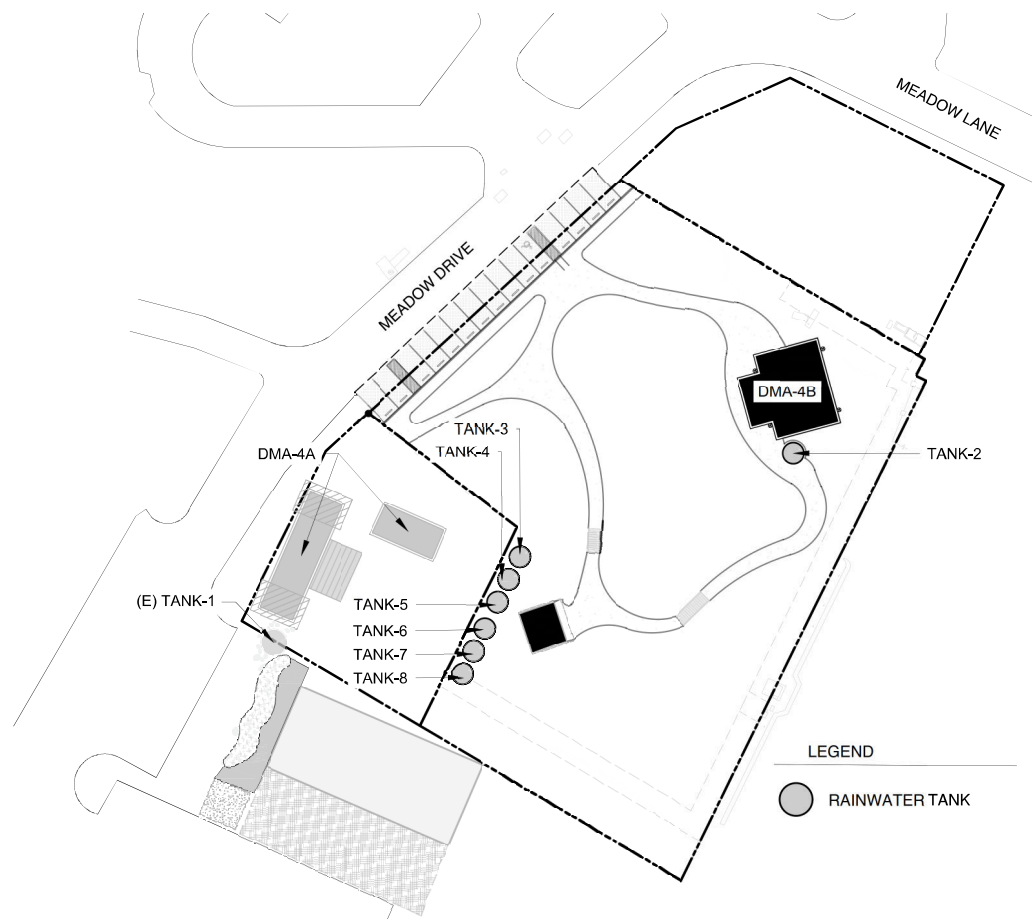

1 RAINWATER HARVESTING

2 STORMWATER BENEFITS

1 RAINWATER HARVESTING

RAINWATER HARVESTING BENEFIT					
PROPOSED BMP RUNOFF TREATMENT	PLAN REFERENCE	TANK VOLUME GAL	DMA ID	DMA AREA ACRES	TREATED DMA VOLUME AFY
RAINWATER HARVESTING TANKS	TANK-1	4,333	DMA-4A	0.02	0.10
	TANK-2	5,000			
	TANK-3	5,000			
	TANK-4	5,000			
	TANK-5	5,000			
	TANK-6	5,000			
	TANK-7	5,000			
	TANK-8	5,000			
<b>TOTAL</b>		<b>39,333</b>		<b>0.05</b>	<b>0.29</b>

2 STORMWATER BENEFITS

STORMWATER BENEFITS				
PROPOSED BMP RUNOFF TREATMENT	PLAN REFERENCE	AREA (SQ-FT)	TOTAL AREA (SQ-FT)	MINIMUM REQUIRED (SQ-FT)
BIORETENTION BASIN	SW-1	1,004	1,004	900
BIOSWALES	SW-2	327	27,315	25,800
	SW-3	3,166		
	SW-4	698		
	SW-5	500		
	SW-6	4,810		
	SW-7	6,789		
	SW-8	11,025		
	<b>TOTAL</b>			
PERMEABLE PAVEMENT-PARKING	SW-9	2,672	2,672	2,400
PERMEABLE PAVEMENT-PATHWAY	SW-10	5,656	5,628	5,400

NOTE: A BIOSWALE IS A VEGETATED, SHALLOW DEPRESSION THAT IS DESIGNED TO CAPTURE AND TREAT STORMWATER RUNOFF.

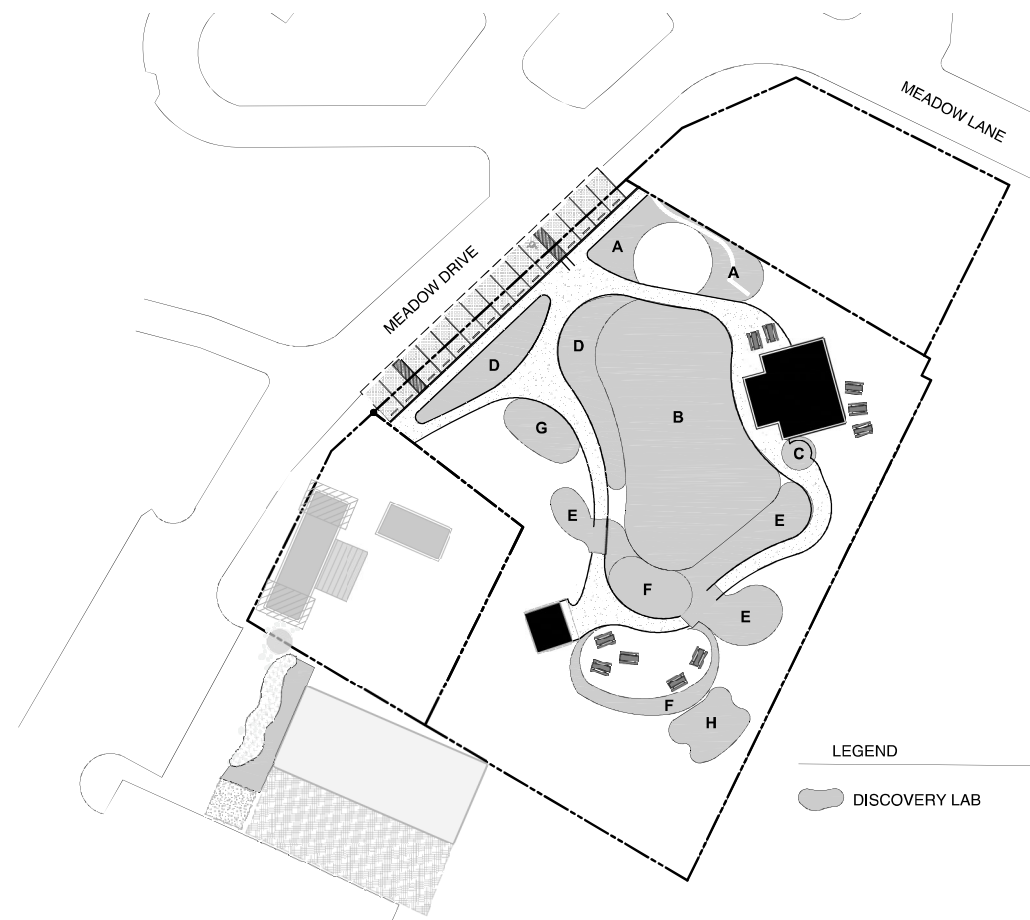
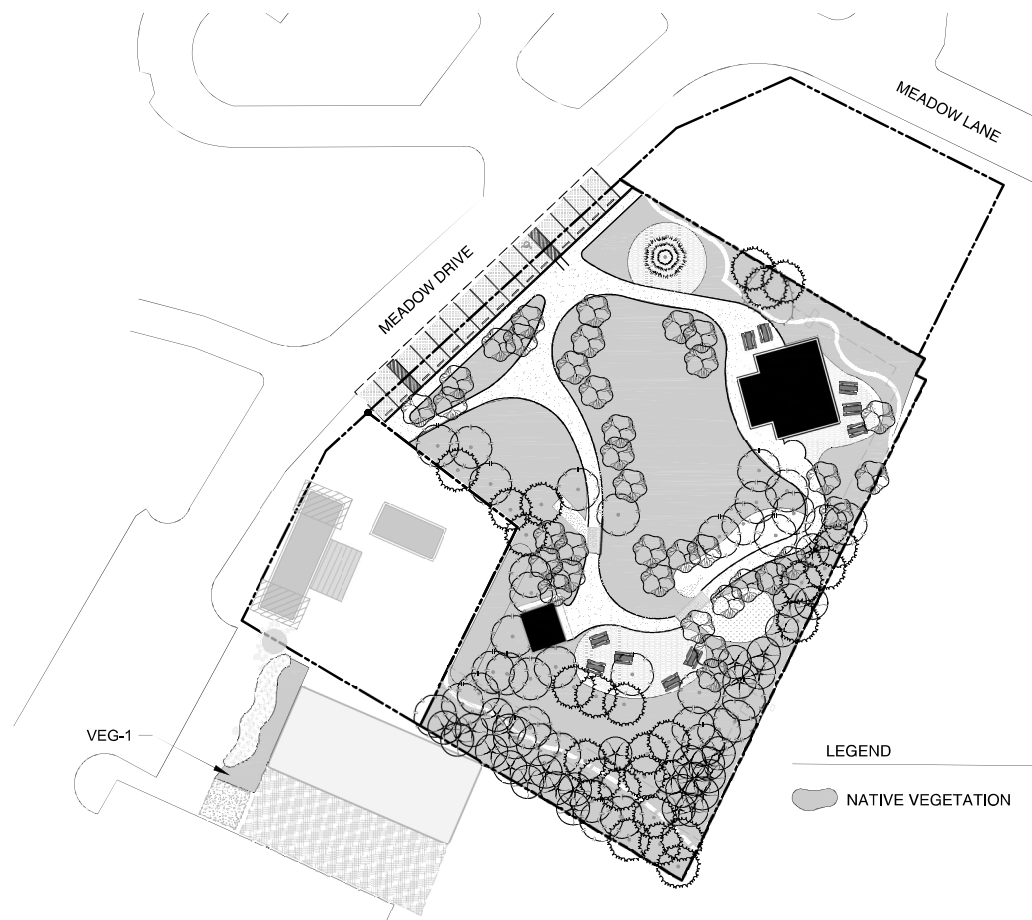

3 NATIVE VEGETATION AND TREES

4 DISCOVERY LABS

3 NATIVE VEGETATION AND TREES

NATIVE VEGETATION BENEFIT				
PROPOSED BMP RUNOFF TREATMENT	PLAN REFERENCE	AREA (SQ-FT)	TOTAL AREA (SQ-FT)	MINIMUM REQUIRED (SQ-FT)
NATIVE VEGETATION	VEG-1	622	622	500

NATIVE VEGETATION BENEFIT		
PROPOSED BMP RUNOFF TREATMENT	NUMBER OF TREES	MINIMUM NUMBER REQUIRED
TREES	124	33

4 DISCOVERY LABS

DISCOVERY LAB BENEFIT		
DISCOVERY LAB DESCRIPTION	PLAN REFERENCE	AREA (SQ-FT)
Living Food Bioswale Fence	A	1,335
Magic of Plants and Pollinators	B	6,790
Rainwater Harvesting	C	191
Stormwater Discovery	D	2,236
Water Play Discovery	E	3,299
Me-Wuk Tribal Stormwater Garden	F	1,486
Soils	G	656
Greywater	H	744
<b>TOTAL</b>		<b>16,737</b>



Twain Harte Meadows Park  
22945 Meadow Drive, Twain Harte, CA 95383

DATE: PROJECT NO.  
 REVISION DATE  
 1 60% DRAFT TO CSD 05.31.22  
 2 60% TO CSD 06.15.22  
 3 60% TO SWB 07.28.22  
 4 100% TO CSD 12.14.22  
 5 100% TO CSD 04.28.23  
 6 100% TO CSD 06.07.23  
 DESIGN BY: MSJS  
 DRAWN BY: MSJS  
 REVIEW BY: JPB, RH, NS

STORMWATER BENEFITS

L0.1

100% CD

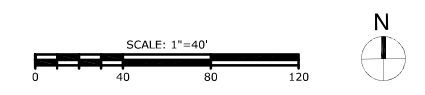

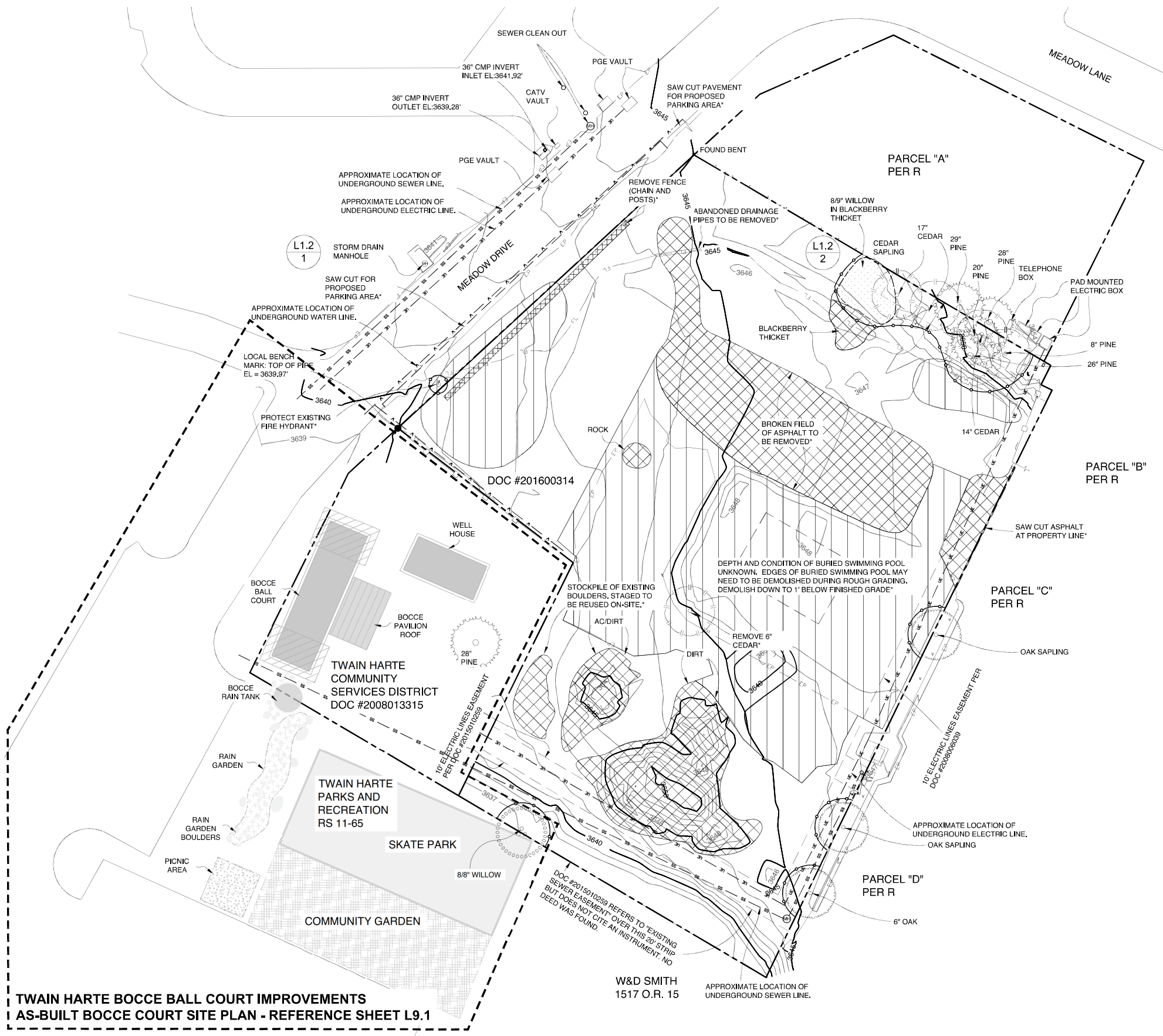

**TWAIN HARTE BOCCÉ BALL COURT IMPROVEMENTS  
AS-BUILT BOCCÉ COURT SITE PLAN - REFERENCE SHEET L9.1**

**GENERAL NOTES**

- A. ALL EXISTING ACTIVE UTILITIES WORK SHALL BE AVOIDED AND PROTECTED WHEN NECESSARY THROUGHOUT CONSTRUCTION.
- B. ALL EXISTING TREES TO BE AVOIDED AND PROTECTED WITH CONSTRUCTION FENCING AT EACH TREE DRIPLINE UNLESS OTHERWISE NOTED FOR REMOVAL.
- C. 811 - KNOW WHAT'S BELOW - CALL BEFORE YOU DIG

**LEGEND**

- PROPERTY BOUNDARY
- 1795 - EXISTING CONTOURS 1'
- 1795 - EXISTING CONTOURS 5'
- SS - 6" SANITARY SEWER
- W - WATER
- FL - FLOW LINE
- EP - EDGE OF PAVEMENT
- F - FENCE
- T - TREE AND SITE AMENITY PROTECTION FENCE
- - EXISTING POST
- V - WATER VALVE
- ⊗ - BOULDER
- MH - MANHOLE
- ⊕ - FIRE HYDRANT
- ⊙ - SEWER CLEAN-OUT
- ▨ - DEMOLITION SCOPE
- ▩ - DEMOLITION SCOPE - ASPHALT/CONCRETE TO SUBGRADE

**SURVEY SHEET NOTES**

TOPOGRAPHIC DATA SHOWN IS BASED ON A SURVEY CONDUCTED BY DAVID H. RAGLAND ENGINEERING AND LAND SURVEYING IN MAY 2022. THE ELEVATIONS SHOWN ON THIS SHEET ARE REFERENCED TO AN ELLIPSOID GPS OBSERVATION. THE CONVERSION FROM THIS DATUM TO NAVD88 IS -4 FT AT TWAIN HARTE MEADOWS PARK.

SHOWN DIMENSIONS ARE RECORD DATA PER RECORD OF SURVEY 45  
 R - RECORD PER PM 49-17  
 R2 - RECORD PER R/S 45-60

**SURVEYOR**  
 DAVID RAGLAND  
 ENGINEERING AND LAND SURVEYING  
 19545 ROGERS ROAD  
 PHONE: (209) 532-7491  
 FAX: (209) 532-8590  
 EMAIL: DRAGLAND@MLODE.COM

**DEMOLITION NOTES**

- A. THE INTENT OF THE DEMOLITION ON THIS PROJECT INVOLVES THE COMPLETE REMOVAL AND LEGAL DISPOSAL OF ASPHALT, CONCRETE, STOCKPILED SOIL MOUNDS, ABANDONED PIPES, AND OTHER MATERIALS AS INDICATED. \*
- B. ALL ROCK LARGER THAN 6 INCHES, CONCRETE, ASPHALT, AND OTHER EXISTING MATERIALS INDICATED ON THE PLANS TO BE REMOVED FROM SITE BY CONTRACTOR. \*
- C. CONTRACTOR TO VERIFY LOCATIONS OF EXISTING EQUIPMENT, PIPING AND SYSTEM COMPONENTS PRIOR TO DEMOLITION. IF EXISTING CONDITIONS ARE DIFFERENT THAN WHAT IS INDICATED ON THE CONTRACT DOCUMENTS, THE CONTRACTOR SHALL NOTIFY THE ENGINEER PRIOR TO PROCEEDING WITH WORK. \*
- D. MINIMIZE DISTURBANCE AND/OR DAMAGE TO EXISTING PROPERTY. WHERE DEMOLITION OF SYSTEM COMPONENTS DAMAGES EXISTING PROPERTY TO REMAIN OCCURS, PROPERTY SHALL BE RESTORED TO BE THE SAME CONDITION AS ORIGINAL AT CONTRACTORS COST. RESTORATION MUST BE PERFORMED BY WORKMEN SKILLED IN PERFORMING SUCH WORK. \*
- E. THE CONTRACTOR SHALL THOROUGHLY EXAMINE THE SITE PRIOR TO SUBMITTING A BID. DUE TO THE NATURE OF THIS PROJECT AND THE STATE OF THE EXISTING SITE. IT IS IMPOSSIBLE TO COMPLETELY RELATE THE SCOPE OF THE DEMOLITION REQUIRED TO THE CONTRACTOR THROUGH THE CONTRACT DOCUMENTS. FAILURE TO VISIT THE SITE WILL NOT RELIEVE THE CONTRACTOR OF DEMOLITION RESPONSIBILITIES UNDER THIS CONTRACT. IT IS THE CONTRACTOR'S RESPONSIBILITY TO DETERMINE AND COORDINATE THE EXACT CONTENT OF DEMOLITION NECESSARY TO PROVIDE A RENOVATED AND UPGRADED SPACE AND TO FACILITATE NEW WORK. \*
- F. VERIFY EXTENT OF PIPING, EQUIPMENT, COMPONENTS AND CONTROLS TO BE RETAINED OR REUSED PRIOR TO THE DEMOLITION OF SPECIFIC SYSTEM. PROTECT ITEMS WHICH ARE TO BE REUSED ON SITE TO MINIMIZE POST CONSTRUCTION REPAIRS. ANY ITEMS WHICH ARE DAMAGED SHALL BE THE RESPONSIBILITY OF THE CONTRACTOR AND SHALL BE REPAIRED OR REPLACED AT NO ADDITIONAL COST TO THE CONTRACT. \*
- G. PROTECT ALL EXISTING TREES WHICH ARE TO REMAIN WITH TREE PROTECTION FENCING. \*
- H. THE CONTRACTOR SHALL REFER TO ALL SECTIONS AND DRAWINGS OF THE CONTRACT DOCUMENTS FOR DEMOLITION OF SYSTEM COMPONENTS INCLUDED IN THE CONTRACT. NOTIFY THE ENGINEER/OWNER OF ALL DISCREPANCIES OR QUESTIONS PERTAINING TO EXTENT OF WORK PRIOR TO BIDDING. \*
- I. DEMOLITION CONTRACTOR SHALL COORDINATE ALL WORK WITH ALL OTHER CONTRACTORS INVOLVED AS DEFINED IN THE SPECIFICATIONS. \*



WATERSHED PROGRESSIVE  
 WWW.WATERSHEDPROGRESSIVE.COM  
 209.732.0016  
 CENTRAL SIERRA OFFICE  
 19653 MAIN STREET  
 GROVELAND, CALIFORNIA 95321  
 OJAI OFFICE  
 206 N. SIGNAL ST., SUITE 9  
 OJAI, CALIFORNIA 93023



**Twain Harte Meadows Park**  
**22945 Meadow Drive, Twain Harte, CA 95383**

REVISION	DATE
1 60% DRAFT TO CSD	05.31.22
2 80% TO CSD	06.15.22
3 80% TO SWB	07.28.22
4 100% TO CSD	12.14.22
5 100% TO CSD	04.28.23
6 100% TO CSD	06.07.23

DESIGN BY: MS  
 DRAWN BY: MSJS  
 REVIEW BY: JPB

© 2023 Watershed Progressive. The design ideas and plans represented by these documents are the property of Watershed Progressive. Use or copy is permitted by contract only. The use or revisions of these ideas or plans is prohibited without the written permission of Watershed Progressive.

**EXISTING CONDITIONS SURVEY AND DEMOLITION**

**L1.1**

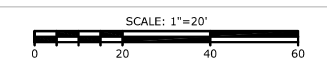



WATERSHED PROGRESSIVE  
 WWW.WATERSHEDPROGRESSIVE.COM  
 209.752.0018  
 CENTRAL SIERRA OFFICE  
 19653 MAIN STREET  
 GROVELAND, CALIFORNIA 95321  
 OJAI OFFICE  
 206 N. SIGNAL ST., SUITE 9  
 OJAI, CALIFORNIA 93023



Twain Harte Meadows Park  
 22945 Meadow Drive, Twain Harte, CA 95383

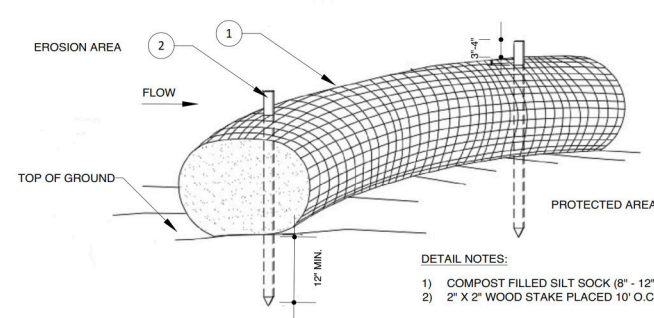

- DETAIL NOTES:**
- 1) COMPOST FILLED SILT SOCK (8" - 12" TYP.)
  - 2) 2" X 2" WOOD STAKE PLACED 10' O.C.
- GENERAL NOTES:**
- A. COMPOST SOCKS TO BE APPLIED DURING RAINY SEASON (MID OCTOBER TO MID APRIL).
  - B. COMPOST SOCKS THAT ARE 8 INCHES IN DIAMETER WILL BE INSTALLED ALONG 2:1 SLOPES OR STORM DRAINS.
  - C. COMPOST SOCKS THAT ARE 12 INCHES IN DIAMETER WILL BE INSTALLED ALONG THE TOE OF 4:1 SLOPES OR STORM DRAINS.
  - D. COMPOST SOCK WILL BE INSTALLED IN ACCORDANCE WITH CAL-TRANS STANDARD PLAN HS1.
  - E. COMPOST SOCK WILL BE MADE OF NATURAL FIBERS (E.G., COTTON, JUTE, SISAL, BURLAP, WOOD-BASED YARN, OR COIR). THE COMPOST SOCK SHOULD NOT CONTAIN A POLYPROPYLENE MESH.

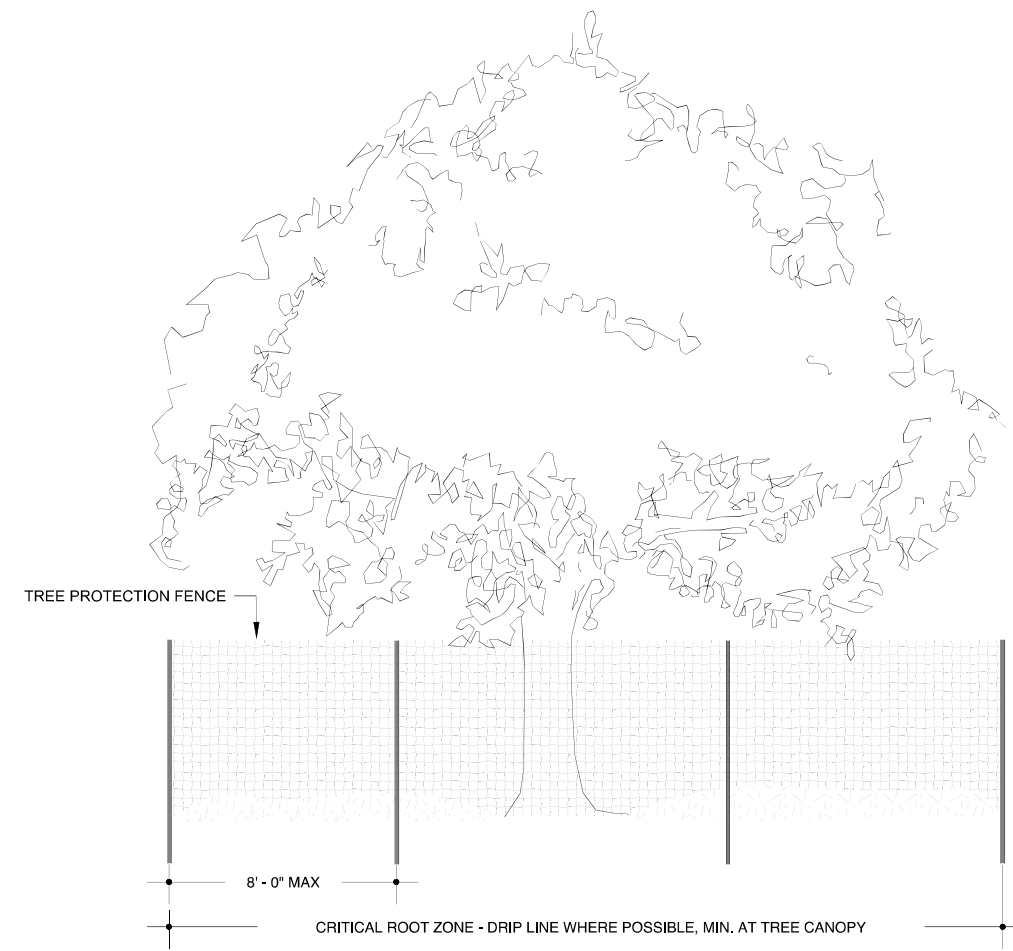

- DETAIL NOTES:**
1. CONTRACTOR SHALL USE TREE PROTECTION FENCING TO PROTECT OAK AND OTHER NATIVE TREES DURING CONSTRUCTION - INCLUDING INVASIVE TREE REMOVAL, GRADING, AND OTHER CONSTRUCTION - TO PROTECT CRITICAL ROOT ZONE.
  2. CONTRACTOR SHALL NOT CUT OR FILL WITHIN CRITICAL ROOT ZONE DURING GRADING.
  3. CONTRACTOR SHALL CONSULT A CERTIFIED ARBORIST BEFORE CUTTING ROOTS ON OAKS AND OTHER NATIVE TREES.
  4. CONTRACTORS SHALL NOT STOCKPILE CONSTRUCTION MATERIALS, TOOLS, OR MACHINERY WITHIN CRITICAL ROOT ZONE.
  5. WHEN REMOVING INVASIVE TREES IN CLOSE PROXIMITY TO OAKS AND OTHER NATIVE TREES WHERE FENCING MAY NOT BE POSSIBLE, CONTRACTOR SHALL USE AS MUCH PROTECTION AS IS POSSIBLE TO AVOID DISTURBING ROOT ZONE.
  6. WHEN LAWN REMOVAL AND NEW PLANTING IS SPECIFIED WITHIN CRITICAL ROOT ZONE, CONTRACTOR SHALL TAKE PRECAUTIONS TO MINIMIZE ROOT DISTURBANCE.

DATE:  
PROJECT NO.

REVISION	DATE
1 60% DRAFT TO CSD	05.31.22
2 60% TO CSD	06.15.22
3 60% TO SWB	07.28.22
4 100% TO CSD	12.14.22
5 100% TO CSD	04.28.23
6 100% TO CSD	06.07.23

DESIGN BY: MS  
 DRAWN BY: MS,JS  
 REVIEW BY: JPB

© 2023 Watershed Progressive. The design ideas and plans represented by these documents are the property of Watershed Progressive. Use or copy is permitted by contract only. The use or revisions of these ideas or plans is prohibited without the written permission of Watershed Progressive.

DEMOLITION AND EROSION CONTROL DETAILS

L1.2



**GENERAL NOTES**

- A. ALL EXISTING ACTIVE UTILITIES WORK SHALL BE AVOIDED AND PROTECTED WHEN NECESSARY THROUGHOUT CONSTRUCTION.
- B. 811 - KNOW WHAT'S BELOW - CALL BEFORE YOU DIG
- C. TOPOGRAPHIC DATA SHOWN IS BASED ON A SURVEY CONDUCTED BY DAVID H. RAGLAND ENGINEERING AND LAND SURVEYING IN MAY 2022. THE ELEVATIONS SHOWN ON THIS SHEET ARE REFERENCED TO AN ELLIPSOID GPS OBSERVATION. THE CONVERSION FROM THIS DATUM TO NAVD88 IS -4 FT AT TWAIN HARTE MEADOWS PARK.
- D. THE CONTRACTOR IS RESPONSIBLE FOR PERFORMING HIS OR HER OWN QUANTITY TAKE-OFF. QUANTITIES ARE PROVIDED AS ESTIMATE ONLY AND AS SUCH ARE NOT TO BE USED FOR BID PURPOSES UNLESS VERIFIED.
- E. THE ELEVATIONS SHOWN ON THIS PLAN REPRESENT FINISHED GRADE (FG).

- LEGEND**
- PROPERTY BOUNDARY
  - BIOSWALE CENTER CHANNEL LINE
  - LOD LIMIT OF DISTURBANCE
  - (E) EXISTING
  - (N) NEW

- SHEET NOTES**
- \* 1 SEE PUBLIC RESTROOM COMPANY PLANS FOR RESTROOM PAD DETAILS. 284 SF
  - \* 2 PROPOSED PAVILION (SEE STRUCTURAL PLANS)
  - \* 3 PROPOSED RETAINING WALL (SEE DETAIL 1 ON SHEET L2.4)
  - \* 4 3-INCH HDPE PIPE 63 LF
  - \* 5 6-INCH HDPE PIPE 38 LF
  - \* 6 CATCH BASIN INLET (SEE DETAIL 4 ON SHEET L2.3) 4 EA
  - \* 7 GRAVEL PAD FOR RAIN TANK FARM (SEE DETAIL 10 ON SHEET L6.4) 106 SF
  - \* 8 PREFORMED SCOUR HOLE (SEE DETAIL 3 ON SHEET L2.3) 4 EA
  - \* 9 GRAVEL PAD FOR RAINWATER HARVESTING DISCOVERY LAB (SEE DETAIL 10 ON SHEET L6.4) 744 SF
  - \* 10 PERMEABLE PATHWAY (SEE SHEET L3.2) 5656 SF
  - \* 11 TRUEGRID PRO PLUS PERMEABLE PAVEMENT (OR APPROVED EQUAL) PARKING LOT (SEE DETAIL 2 ON SHEET L2.4) 2366 SF
  - \* 12 SINGLE CURB (SEE CALTRANS STANDARD PLAN A87A, TYPE B1-6) 157 LF
  - \* 13 ADA CURB RAMP (SEE CALTRANS STANDARD PLAN A88A, CASE C) 1 EA
  - \* 14 TRUEGRID PERMEABLE DECK OR APPROVED EQUAL 306 SF
  - \* 15 TRUEGRID SNOWSPOT PAVING MARKERS OR APPROVED EQUAL
  - \* 16 TANK-3 EXCAVATION (SEE DETAIL 12 ON SHEET L6.5)
  - \* 17 WATER PLAY DISCOVERY LAB (SEE SHEET L8.1)
  - \* 18 GRAVEL OR WALKABLE MULCH BASE FOR WOODEN FLUME 220 SF
  - \* 19 SAWCUT TO CREATE A CLEAN EDGE WITH EXISTING PAVEMENT. ENSURE PAVERS ARE FLUSH OR SLIGHTLY RECESSED BELOW SURROUNDING GRADE. (SEE DETAIL 3 ON SHEET L2.4) 149 LF
  - \* 20 PAINT VISUAL CONNECTION OF EXISTING BOCCIE BALL COURTS TO PROPOSED TWAIN HARTE MEADOWS PARK
  - \* 21 PEDESTRIAN BOARDWALK (SEE USFS STANDARD PLAN FOR SAWN TIMBER STRINGER TRAIL BRIDGE) 141 SF
  - \* 22 EXISTING BIOSWALE (SEE SHEET L9.1)
  - \* 23 EXISTING RAIN TANK (SEE SHEET L9.1)
  - \* 24 LIMITS OF DISTURBANCE 0.95 AC
  - \* 25 GRAVEL ACCESS WALKWAY FOR RESTROOM 62 SF

ESTIMATED EARTHWORK QUANTITIES	
RAW FINISHED GRADE CUT (-)	1,104 CY
RAW FINISHED GRADE FILL (+)	280 CY
FILL REDUCTION FOR MATERIALS BELOW FG (-)	129 CY
FILL INCREASE FOR DIRT LOSS ACROSS GRADING AREA (+)	164 CY
NET QUANTITY (+ FOR IMPORT)	-790 CY
DEPTH IMBALANCE ACROSS THE GRADING AREA	-0.5 FT

NOTE: 150 CY OF GRADE CUT CAN BE ATTRIBUTED TO THE DEBRIS PILES DEPICTED IN THE TOPOGRAPHIC SURVEY.



Twain Harte Meadows Park  
 22945 Meadow Drive, Twain Harte, CA, 95383

DATE: PROJECT NO.

REVISION	DATE
1 60% DRAFT TO CSD	05.31.22
2 60% TO CSD	06.15.22
3 60% TO SWB	07.28.22
4 100% TO CSD	12.14.22
5 100% TO CSD	04.28.23
6 100% TO CSD	06.07.23

DESIGN BY: ABR  
 DRAWN BY: JS, MS  
 REVIEW BY: RH, NS, JPB

© 2023 Watershed Progressive. The design ideas and plans represented by these documents are the property of Watershed Progressive. Use or copy is permitted by contract only. The use or revisions of these ideas or plans is prohibited without the written permission of Watershed Progressive.

**GRADING AND DRAINAGE PLAN**

**L2.1**

100% CD

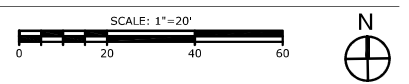



WATERSHED PROGRESSIVE  
 WWW.WATERSHEDPROGRESSIVE.COM  
 209.732.0018  
 CENTRAL SIERRA OFFICE  
 19653 MAIN STREET  
 GROVELAND, CALIFORNIA 95321  
 OJAI OFFICE  
 206 N. SIGNAL ST., SUITE 5  
 OJAI, CALIFORNIA 93023

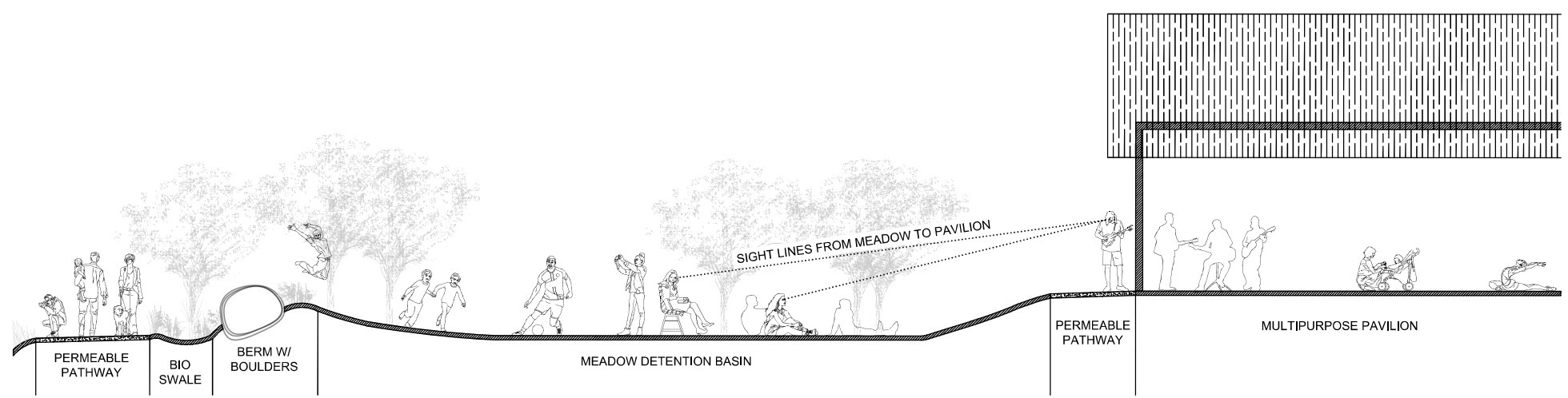

1 SECTION: PAVILION AND MEADOW

SCALE 1" = 5'  
 0 5 10 15

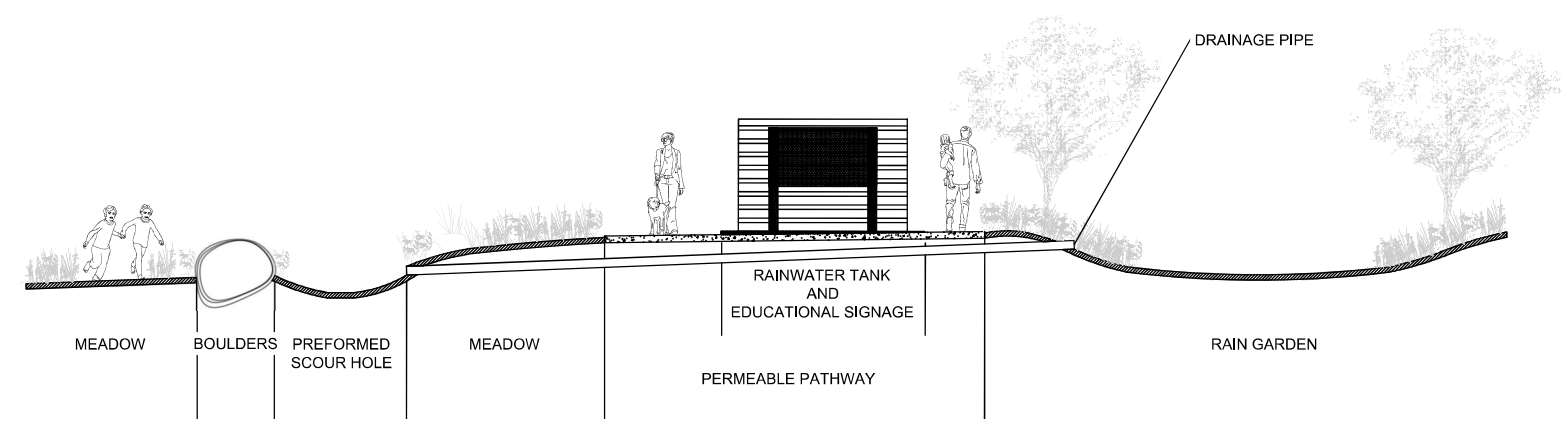

2 SECTION: RAIN GARDEN TO MEADOW

SCALE 1" = 5'  
 0 5 10 15

Twain Harte Meadows Park  
 22945 Meadow Drive, Twain Harte, CA, 95383

DATE:  
 PROJECT NO.

REVISION	DATE
1 60% DRAFT TO CSD	05.31.22
2 60% TO CSD	06.15.22
3 60% TO SWB	07.28.22
4 100% TO CSD	12.14.22
5 100% TO CSD	04.28.23
6 100% TO CSD	06.07.23

DESIGN BY: ABR  
 DRAWN BY: JS, MS  
 REVIEW BY: RH, NS, JPB

© 2023 Watershed Progressive. The design ideas and plans represented by these documents are the property of Watershed Progressive. Use or copy is permitted by contract only. The use or revisions of these ideas or plans is prohibited without the written permission of Watershed Progressive.

GRADING AND DRAINAGE SECTIONS

L2.2

100% CD



WATERSHED PROGRESSIVE  
 WWW.WATERSHEDPROGRESSIVE.COM  
 209.732.0018  
 CENTRAL SIERRA OFFICE  
 18653 MAIN STREET  
 GROVELAND, CALIFORNIA 95321  
 OJAI OFFICE  
 206 N. SIGNAL ST., SUITE 3  
 OJAI, CALIFORNIA 93023

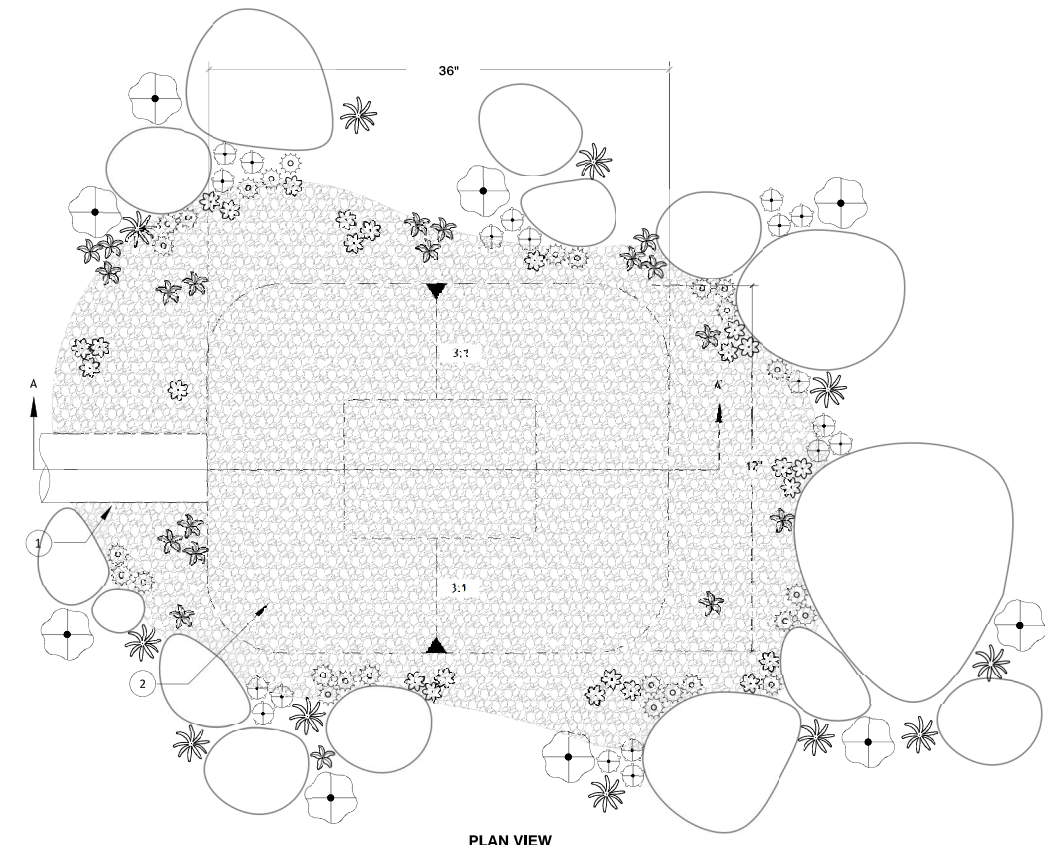

PLAN VIEW

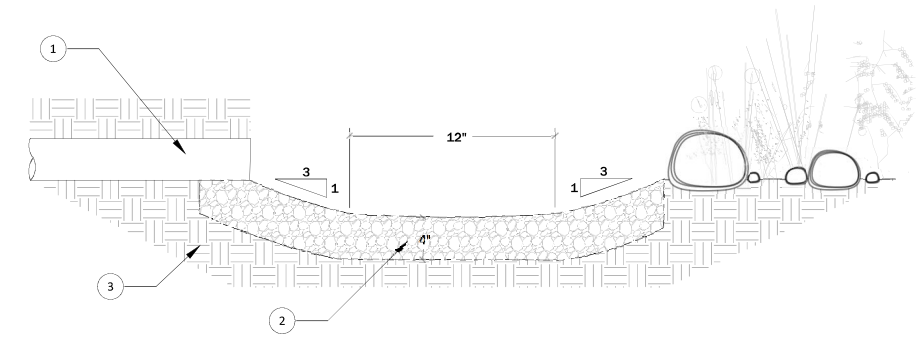

SECTION A - A'

DETAIL NOTES:  
 1. HDPE PIPE (SIZE VARIES - REFERENCE PLANS)  
 2. GRAVEL (CLASS II PERMEABLE)  
 3. UNDISTURBED SUBGRADE

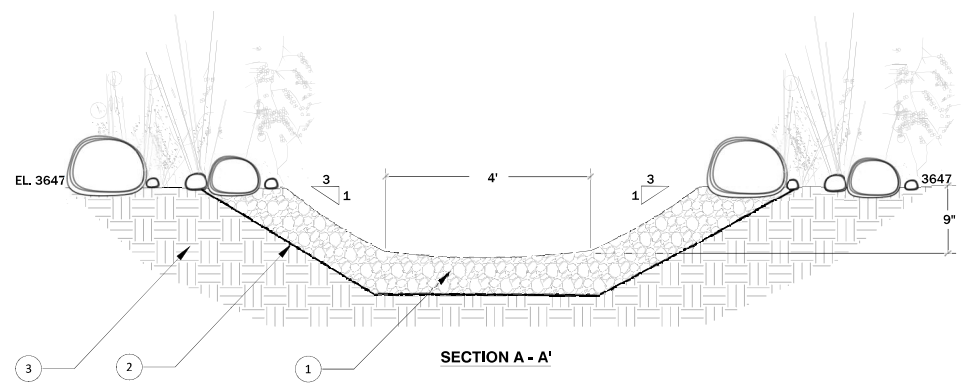

SECTION A - A'

DETAIL NOTES:  
 1. 6" GRAVEL (CLASS II PERMEABLE PER CALTRANS STD SPEC 68-2.02F(3)) COMPACTED TO 95%  
 2. RSP FABRIC  
 3. UNDISTURBED SUBGRADE

1 SW-4 RAIN GARDEN DETAIL  
 NOT TO SCALE

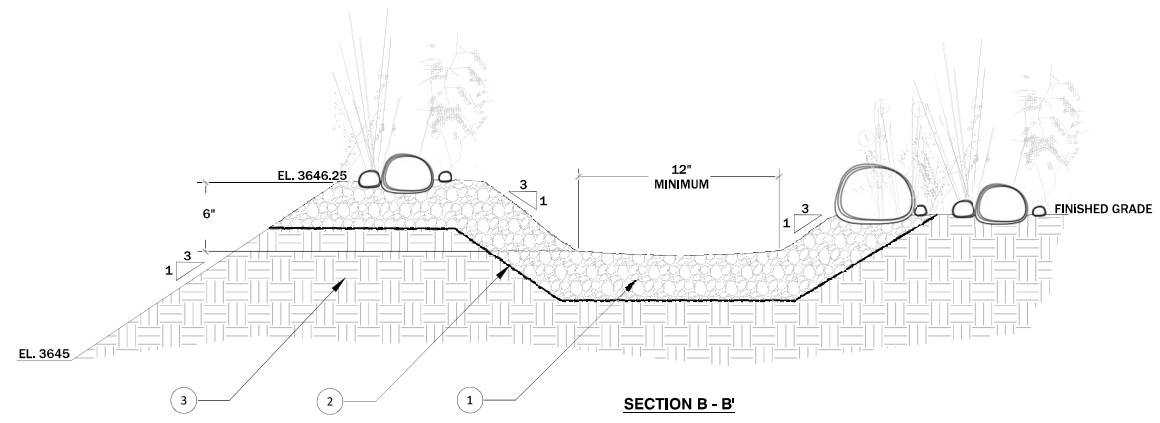

SECTION B - B'

DETAIL NOTES:  
 6" GRAVEL (CLASS II PERMEABLE PER CALTRANS STD SPEC 68-2.02F(3)) COMPACTED TO 95%  
 1. RSP FABRIC  
 2. UNDISTURBED SUBGRADE

2 SW-4 RAIN GARDEN DETAIL  
 NOT TO SCALE

3 PREFORMED SCOUR HOLE  
 NOT TO SCALE

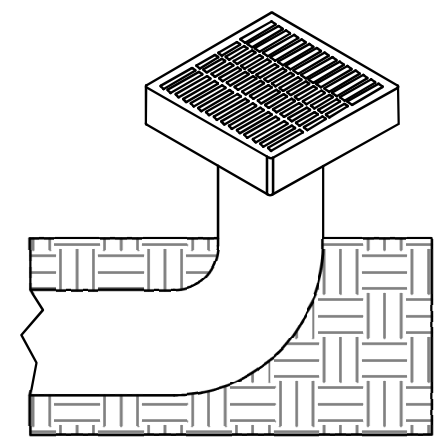

4 INLET BOX FOR HDPE PIPES (TYP.)  
 NOT TO SCALE

DATE:  
 PROJECT NO.

REVISION	DATE
1 60% DRAFT TO CSD	05.31.22
2 60% TO CSD	06.15.22
3 60% TO SWB	07.28.22
4 100% TO CSD	12.14.22
5 100% TO CSD	04.28.23
6 100% TO CSD	06.07.23

DESIGN BY: ABR  
 DRAWN BY: JS, MS  
 REVIEW BY: RH, NS, JPB

© 2023 Watershed Progressive. The design ideas and plans represented by these documents are the property of Watershed Progressive. Use or copy is permitted by contract only. This use or revisions of these ideas or plans is prohibited without the written permission of Watershed Progressive.

GRADING AND DRAINAGE DETAILS

L2.3

100% CD

Twain Harte Meadows Park  
 22945 Meadow Drive, Twain Harte, CA, 95383

**NOTES:**

- SUB-BASE DEPTH AND PREPARATION IS DEPENDENT ON SITE CONDITIONS PLUS LOADING REQUIREMENTS.
- TRUEGRID PRO PLUS PRODUCTS DESIGNED FOR LOAD CAPACITIES OF 120,000 LBS PER SQ. FT. TRUEGRID PRODUCTS STRENGTHEN WITH FILL MATERIAL.
- TRUEGRID PRO PLUS PRODUCTS ARE SUFFICIENTLY RATED FOR H-20 /HS-20 LOADING AND GREATER.
- GEGRID MESH OR GEOTEXILIC MAY BE REQUIRED BETWEEN SUB-GRADE & SUB-BASE FOR CERTAIN SOILS AND SITE SPECIFIC REQUIREMENTS.
- INCREASE SUB-BASE DEPTH FOR INCREASED STORM WATER DETENTION.
- NO STAKING NECESSARY WITH TRUEGRID PRO PLUS WHEN SLOPE IS BELOW 10 DEGREES. ASSESS PROJECT, AS NEEDED.
- FINAL ENGINEERED CROSS SECTION AGGREGATES AND DEPTH SHOULD ALLOW FOR EXPECTED INFILTRATION RATES, STORAGE CAPACITIES, OUTLET FLOW RATES, AND OTHER SITE SPECIFIC CONDITIONS AND LOAD REQUIREMENTS.
- THIS CROSS SECTION IS FOR INFORMATION ONLY.

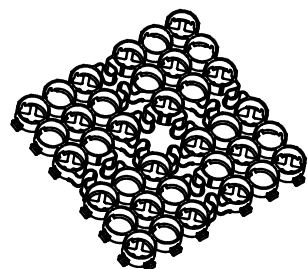

**TRUEGRID BLOCK REFERENCE VIEW**  
PREASSEMBLED & DELIVERED IN 4' X 4' SHEET, RECONFIGURED AS NEEDED FOR EXTRA TOLLING OR ACCESSORIES REQUIRED

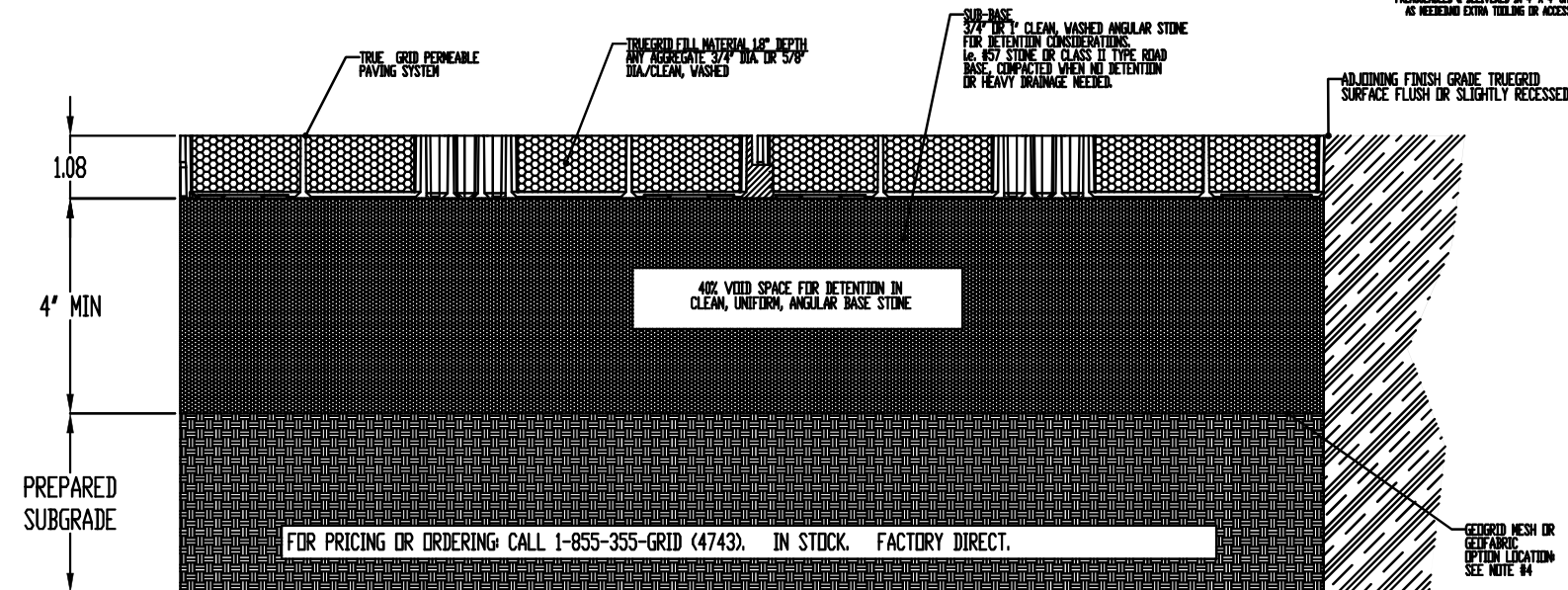

FOR PRICING OR ORDERING: CALL 1-855-355-GRID (4743). IN STOCK. FACTORY DIRECT.

GRAVEL FILL MEDIUM LOAD TRUEGRID PRO PLUS

APPLICATION:  
PARKING LOT, RV PARKING,  
PARKING PADS, DRIVEWAYS

1-855-355-GRID (4743)	CLIENT / PROJECT	<p>TRUE to your project. True to the environment.</p>
<p>U.S.A. TRUEGRIDPAVER.com</p>	<p><b>TRUEGRID GRAVEL FILL INSTALLATION MEDIUM LOAD</b></p> <p>TG-GRV-ML</p>	

**2 GRAVEL FILL MEDIUM LOAD PERMEABLE PAVER**  
NOT TO SCALE

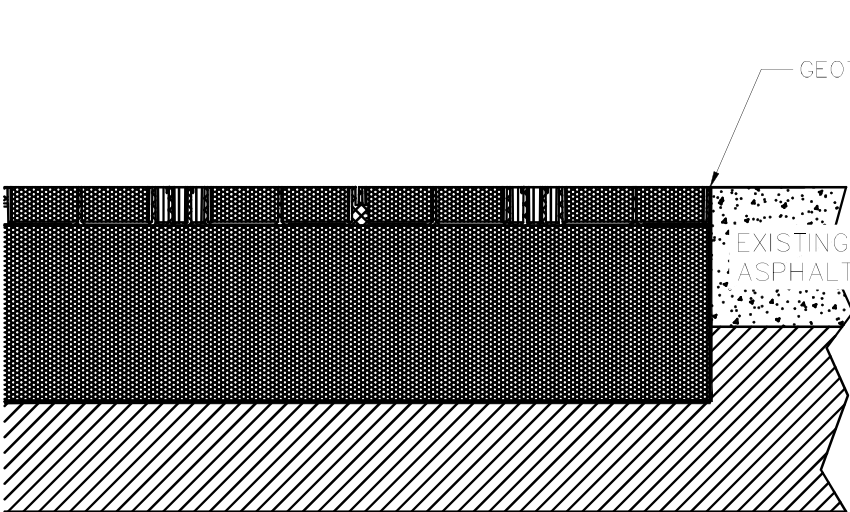

CONCRETE RIBBON EDGING OR TRANSITION TO HARDSCAPE

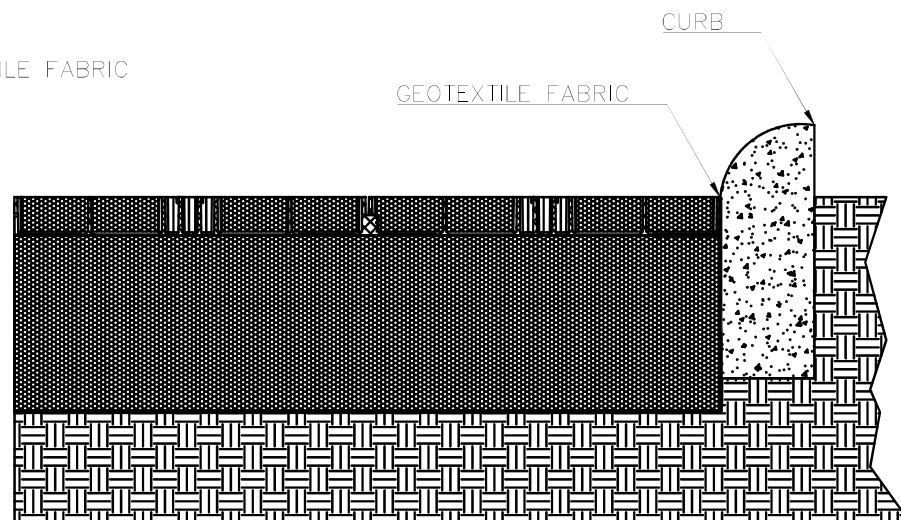

CONCRETE CURB EDGING

**3 PERMEABLE PAVER TRANSITION TO HARDSCAPE AND CURB**  
NOT TO SCALE

TABLE A

Wall Height (feet)	Slope of Retained Earth (Horizontal Run to Vertical Rise)																			
	3 to 1				2 to 1				1.5 to 1											
	T	R	K	W	T	R	K	W	T	R	K	W								
1.5'	A	1	N	1'-4"	A	1	N	1'-4"	A	1	N	1'-4"	A	1	N	1'-5"	A	1	N	1'-7"
2.0'	A	1	N	1'-4"	A	1	N	1'-4"	A	1	N	1'-4"	A	1	D	1'-8"	A	1	D	1'-10"
2.5'	A	1	N	1'-7"	A	1	N	1'-7"	A	1	N	1'-7"	A	1	N	1'-10"	A	1	E	2'-2"
3.0'	A	1	N	2'-0"	A	1	N	2'-0"	A	1	D	2'-0"	A	1	E	2'-2"	B	1	F	2'-5"
3.5'	A	1	N	2'-1"	A	3	D	2'-1"	A	3	D	2'-1"	B	1	E	2'-4"	B	4	F	3'-4"
4.0'	B	1	N	2'-4"	B	1	D	2'-4"	B	1	D	2'-4"	B	4	F	2'-5"	B	6	G	3'-4"
4.5'	B	1	N	2'-6"	B	2	D	2'-6"	B	4	E	2'-6"	B	6	F	3'-1"	C	5	G	3'-9"
5.0'	B	4	D	2'-9"	B	5	E	2'-9"	B	6	F	2'-9"	C	5	G	3'-5"				
5.5'	B	5	D	3'-0"	B	6	E	3'-0"	C	5	F	3'-2"	C	5	G	3'-9"				
6.0'	C	5	E	3'-3"	C	5	E	3'-4"	C	5	F	3'-6"	C	6	G	4'-2"				
7.0'	C	5	E	3'-10"	C	6	G	3'-11"	C	7	G	4'-1"								
8.0'	C	5	G	4'-6"																

TABLE B

T Wall Type*	R Reinforcing Steel	K Key Size (Width x Depth)
A - Type I, 6" block	1 - #3 Bars @ 24" o.c.	D - 6" x 6"
B - Type I, 8" block	2 - #4 Bars @ 32" o.c.	E - 8" x 8"
C - Type II, first 32" of block must be 12" wide masonry, regardless of wall height (see sketch), 8" block for remainder	3 - #3 Bars @ 16" o.c.	F - 12" x 12"
	4 - #4 Bars @ 24" o.c.	G - 12" x 18"
	5 - #4 Bars @ 16" o.c.	N - None
	6 - #5 Bars @ 16" o.c.	
	7 - #6 Bars @ 16" o.c.	

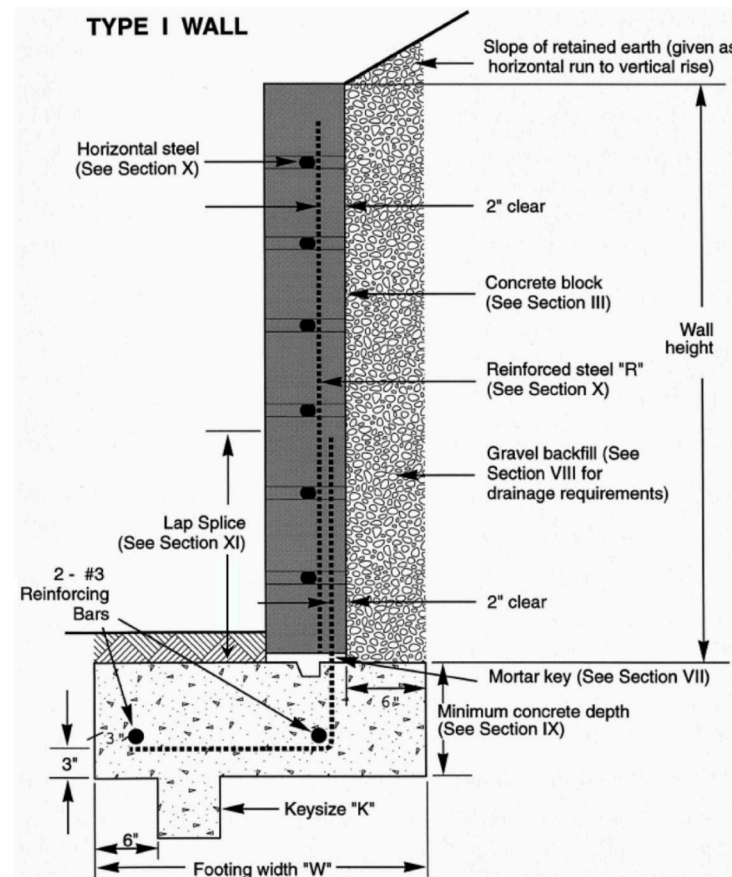

NOTE: The bottom leading edge of all retaining wall footings shall be 7'-0" minimum from FACE of slopes where the ground slopes away from the wall.

COUNTY OF SAN DIEGO, PLANNING AND DEVELOPMENT SERVICES

**1 PAVILION RETAINING WALL DETAIL**  
NOT TO SCALE



Twain Harte Meadows Park  
22945 Meadow Drive, Twain Harte, CA, 95383

DATE:	PROJECT NO.	DATE
REVISION	1 60% DRAFT TO CSD	05.31.22
2 60% TO CSD	06.15.22	
3 60% TO SWB	07.28.22	
4 100% TO CSD	12.14.22	
5 100% TO CSD	04.28.23	
6 100% TO CSD	06.07.23	

DESIGN BY: ABR  
DRAWN BY: JS, MS  
REVIEW BY: RH, NS, JPB

GRADING AND DRAINAGE DETAILS

L2.4



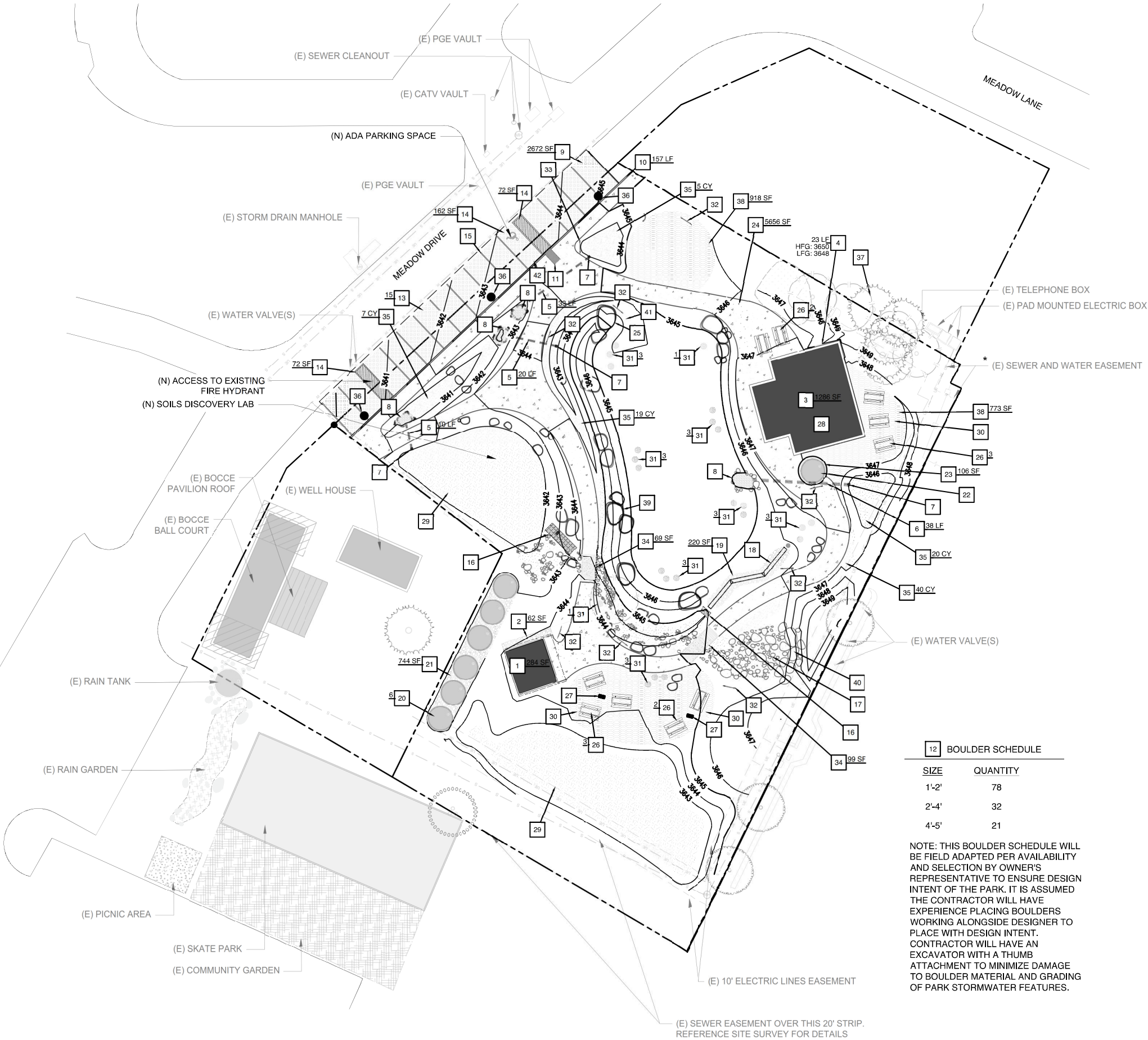

12 BOULDER SCHEDULE	
SIZE	QUANTITY
1'-2'	78
2'-4'	32
4'-5'	21

NOTE: THIS BOULDER SCHEDULE WILL BE FIELD ADAPTED PER AVAILABILITY AND SELECTION BY OWNER'S REPRESENTATIVE TO ENSURE DESIGN INTENT OF THE PARK. IT IS ASSUMED THE CONTRACTOR WILL HAVE EXPERIENCE PLACING BOULDERS WORKING ALONGSIDE DESIGNER TO PLACE WITH DESIGN INTENT. CONTRACTOR WILL HAVE AN EXCAVATOR WITH A THUMB ATTACHMENT TO MINIMIZE DAMAGE TO BOULDER MATERIAL AND GRADING OF PARK STORMWATER FEATURES.

GENERAL NOTES

- A. ALL EXISTING ACTIVE UTILITIES WORK SHALL BE AVOIDED AND PROTECTED WHEN NECESSARY THROUGHOUT CONSTRUCTION.
- B. 811 - KNOW WHAT'S BELOW - CALL BEFORE YOU DIG
- C. ALL PATHWAYS SHALL BE A MINIMUM OF 48" IN WIDTH TO COMPLY WITH CALIFORNIA ADA REQUIREMENTS.
- D. TOPOGRAPHIC DATA SHOWN IS BASED ON A SURVEY CONDUCTED BY DAVID H. RAGLAND ENGINEERING AND LAND SURVEYING IN MAY 2022. THE ELEVATIONS SHOWN ON THIS SHEET ARE REFERENCED TO AN ELLIPSOID GPS OBSERVATION. THE CONVERSION FROM THIS DATUM TO NAVD88 IS -4 FT AT TWAIN HARTE MEADOWS PARK.

SHEET NOTES		
* 1	SEE PUBLIC RESTROOM COMPANY PLANS FOR RESTROOM PAD DETAILS	284 SF
* 2	GRAVEL ACCESS WALKWAY FOR RESTROOM	62 SF
* 3	PROPOSED PAVILION (SEE STRUCTURAL PLANS)	1286 SF
* 4	PROPOSED RETAINING WALL (SEE DETAIL 1 ON SHEET L2.4)	23 LF
* 5	3-INCH HDPE PIPE	63 LF
* 6	6-INCH HDPE PIPE	38 LF
* 7	CATCH BASIN INLET (SEE DETAIL 4 ON SHEET L2.3)	4 EA
* 8	PREFORMED SCOUR HOLE (SEE DETAIL 3 ON SHEET L2.3)	4 EA
* 9	TRUEGRID PRO PLUS PERMEABLE PAVER (OR APPROVED EQUAL) PARKING LOT (SEE DETAIL 2 ON SHEET L2.4)	2366 SF
* 10	SINGLE CURB (SEE CALTRANS STANDARD PLAN A87A, TYPE B1-6)	157 LF
* 11	ADA CURB RAMP (SEE CALTRANS STANDARD PLAN A88A, CASE C)	1 EA
* 12	BOULDER SCHEDULE	15 EA
* 13	PARKING SPOTS (18 FT X 9 FT)	15 EA
* 14	TRUEGRID PERMEABLE DECK OR APPROVED EQUAL*	306 SF
* 15	TRUEGRID SNOWSPOT PAVING MARKERS (OR APPROVED EQUAL)*	
16	TANK-3 INSTALLATION (SEE DETAIL 12 ON SHEET L6.5)	
17	WATER PLAY DISCOVERY LAB (SEE SHEET L8.1)	
18	WOODEN FLUME (SEE SHEET L6.6)	
19	GRAVEL OR WALKABLE MULCH BASE FOR WOODEN FLUME	220 SF
* 20	POLY RAINWATER HARVESTING TANKS (TANK-1)	6 EA
* 21	GRAVEL PAD FOR RAIN TANK FARM (SEE DETAIL 10 ON SHEET L6.4)	744 SF
* 22	CORRUGATED METAL TANK FOR RAINWATER HARVESTING DISCOVERY LAB (TANK-2)*	1 EA
* 23	GRAVEL PAD FOR RAINWATER HARVESTING DISCOVERY LAB (SEE DETAIL 10 ON SHEET L6.4)	106 SF
* 24	GRANITECRETE (OR APPROVED EQUAL) PERMEABLE PATHWAY (SEE LAYOUT PLAN ON SHEET L3.2 AND DETAIL 4 ON SHEET L3.4)	5656 SF
* 25	PLACE BOULDERS (SEE BOULDER SCHEDULE, DETAIL 2 AND 3 ON SHEET L3.3)	
26	PICNIC TABLE WITH CONCRETE FOOTINGS (SEE SECTION 12 93 00 OF SPECIFICATIONS)	10 EA
27	BARBEQUE WITH CONCRETE FOOTING (SEE SECTION 12 93 00 OF SPECIFICATIONS)	2 EA
28	LARGE BARBEQUE, SCULLERY SINK, AND OUTDOOR KITCHEN ISLAND TO BE INSTALLED IN PAVILION (BY OTHERS)	
29	LANDSCAPED AREA	
30	PICNIC AREA	3 EA
31	STEPPING STONE	23 EA
32	DISCOVERY LAB EDUCATIONAL SIGNAGE	8 EA
33	PARK ENTRANCE SIGN	
* 34	RAISED BOARDWALKS PER USFS STD TRAIL PLAN FOR SAWN TIMBER STRINGER TRAIL BRIDGE SHEETS: STD_962-10-01 TO STD_962-10-04	168 SF
* 35	ROCK MULCH AND COBBLE (SEE SECTION 31 20 00, 2.05D OF SPECIFICATIONS)	91 CY
* 36	HAPCO SOLAR LIGHTS (OR APPROVED EQUAL), DIRECT BURY. SEE ELECTRICAL PLANS AND SPEC SECTION 26 56 00.	3 EA
37	EXISTING VEGETATED AREA (SEE SHEET L1.1)	
38	MULCHED AREA	1691 SF
* 39	BOULDERS IN BIOSWALE (SEE BOULDER SCHEDULE AND DETAIL 3 ON SHEET L3.3)	
* 40	BOULDER OUTCROPPING (STEPPED BOULDERS)	
* 41	MAGIC OF PLANTS AND POLLINATORS DISCOVERY LAB	
* 42	HANDICAP SIGN	1 EA



WATERSHED PROGRESSIVE  
 WWW.WATERSHEDPROGRESSIVE.COM  
 209.732.0018  
 CENTRAL SIERRA OFFICE  
 18653 MARY STREET  
 GROVELAND, CALIFORNIA 95321  
 OJAI OFFICE  
 206 N. SIGNAL ST., SUITE 3  
 OJAI, CALIFORNIA 93023



Twain Harte Meadows Park  
 22945 Meadow Drive, Twain Harte, CA, 95383

DATE: PROJECT NO.

REVISION	DATE
1 60% DRAFT TO CSD	05.31.22
2 60% TO CSD	06.15.22
3 60% TO SWB	07.28.22
4 100% TO CSD	12.14.22
5 100% TO CSD	04.28.23
6 100% TO CSD	06.07.23

DESIGN BY: ABR  
 DRAWN BY: MS, JS, DR  
 REVIEW BY: RH, NS, JPB

© 2023 Watershed Progressive. The design ideas and plans represented by these documents are the property of Watershed Progressive. Use or copy is permitted by contract only. The use or revisions of these ideas or plans is prohibited without the written permission of Watershed Progressive.

MATERIALS PLAN

L3.1

100% CD

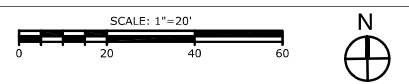



GENERAL NOTES

- A. ALL EXISTING ACTIVE UTILITIES WORK SHALL BE AVOIDED AND PROTECTED WHEN NECESSARY THROUGHOUT CONSTRUCTION.
- B. 811 - KNOW WHAT'S BELOW - CALL BEFORE YOU DIG
- C. ALL PATHWAYS SHALL BE A MINIMUM OF 48" IN WIDTH TO COMPLY WITH CALIFORNIA ADA REQUIREMENTS.
- D. TOPOGRAPHIC DATA SHOWN IS BASED ON A SURVEY CONDUCTED BY DAVID H. RAGLAND ENGINEERING AND LAND SURVEYING IN MAY 2022. THE ELEVATIONS SHOWN ON THIS SHEET ARE REFERENCED TO AN ELLIPSOID GPS OBSERVATION. THE CONVERSION FROM THIS DATUM TO NAVD88 IS -4 FT AT TWAIN HARTE MEADOWS PARK.



WATERSHED PROGRESSIVE  
 WWW.WATERSHEDPROGRESSIVE.COM  
 209.732.0018  
 CENTRAL SIERRA OFFICE  
 18653 MAIN STREET  
 GROVELAND, CALIFORNIA 95321  
 OJAI OFFICE  
 206 N. SIGNAL ST., SUITE 3  
 OJAI, CALIFORNIA 93023



Line Table						
Line #	Length	Direction	Start Northing	Start Easting	End Northing	End Easting
L33	1.71	N18° 29' 01.75"W	4999.26	10282.21	5000.88	10281.66
L34	4.00	S71° 30' 58.25"W	5000.88	10281.66	4999.62	10277.87
L35	9.40	S18° 29' 01.75"E	4999.62	10277.87	4990.70	10280.85
L36	4.05	S18° 29' 01.75"E	4990.70	10280.85	4986.86	10282.13
L37	5.35	S18° 29' 01.75"E	4986.86	10282.13	4981.79	10283.83
L38	3.41	N71° 30' 58.25"E	4981.79	10283.83	4982.87	10287.06
L49	47.11	S46° 39' 29.95"W	5138.26	10268.76	5105.92	10234.50
L50	25.13	S46° 39' 29.95"W	5105.92	10234.50	5088.67	10216.22
L51	4.12	S46° 39' 29.95"W	5088.67	10216.22	5085.85	10213.23
L52	89.62	N46° 39' 29.95"E	5080.38	10200.13	5141.89	10265.31
L53	13.33	N46° 39' 29.95"E	5141.89	10265.31	5151.04	10275.01
L1	10.62	S46° 39' 29.95"W	5185.54	10318.87	5178.26	10311.14
L2	9.80	S46° 39' 29.95"W	5178.26	10311.14	5171.53	10304.02
L3	17.22	S46° 39' 29.95"W	5171.53	10304.02	5159.71	10291.49
L9	17.88	S79° 41' 20.69"E	5142.65	10322.42	5139.45	10340.01
L10	14.51	S79° 41' 20.69"E	5139.45	10340.01	5136.85	10354.28
L11	7.20	S79° 41' 20.69"E	5136.85	10354.28	5135.56	10361.36
L13	15.00	N74° 52' 41.82"E	5115.80	10383.30	5119.71	10397.78
L17	27.00	S74° 52' 41.97"W	5081.09	10408.22	5074.05	10382.15
L18	2.62	S14° 57' 04.47"E	5074.05	10382.15	5071.52	10382.83

Line Table						
Line #	Length	Direction	Start Northing	Start Easting	End Northing	End Easting
L55	0.52	S59° 25' 55.08"E	5188.46	10313.94	5188.19	10314.39
L56	19.46	S46° 39' 29.95"W	5188.19	10314.39	5174.83	10300.23
L57	16.68	S46° 39' 29.95"W	5174.83	10300.23	5163.39	10288.10
L58	5.00	S46° 39' 29.95"W	5163.39	10288.10	5159.95	10284.47

Curve Table									
Curve #	Length	Radius	Delta	Chord Direction	Chord Length	Start Northing	Start Easting	End Northing	End Easting
C25	20.41	58.54	19.98	S2° 07' 51"E	20.31	5112.59	10356.46	5092.30	10357.22
C26	15.01	58.54	14.69	S19° 27' 45"E	14.96	5092.30	10357.22	5078.19	10362.20
C27	34.95	58.54	34.21	S43° 54' 46"E	34.44	5078.19	10362.20	5053.38	10386.09
C28	11.54	14.14	46.77	S33° 26' 16"E	11.23	5053.38	10386.09	5044.02	10392.27
C29	20.66	14.14	83.73	S31° 48' 41"W	18.89	5044.02	10392.27	5027.98	10382.33
C30	44.40	101.44	25.08	S57° 58' 46"W	44.05	5027.98	10382.33	5004.63	10344.98
C20	6.90	18.50	21.38	N6° 12' 28"W	6.87	5112.59	10356.46	5119.41	10355.72
C21	6.90	18.50	21.38	N27° 35' 20"W	6.87	5119.41	10355.72	5125.50	10352.54
C22	7.09	18.50	21.95	N49° 15' 10"W	7.05	5125.50	10352.54	5130.09	10347.21
C23	8.37	18.50	25.92	N73° 11' 11"W	8.30	5130.09	10347.21	5132.49	10339.27
C47	16.65	228.93	4.17	S13° 07' 32"W	16.65	5022.10	10292.80	5005.89	10289.02
C48	7.97	19.53	23.37	S24° 43' 41"W	7.92	5005.89	10289.02	4998.71	10285.71
C49	4.37	2.00	125.10	N81° 02' 04"W	3.55	4998.71	10285.71	4999.26	10282.21
C50	1.12	2.00	32.09	N55° 28' 14"E	1.11	4982.87	10287.06	4983.49	10287.97
C51	2.18	22.30	5.61	N51° 01' 18"E	2.33	4983.49	10287.97	4984.86	10289.67
C52	21.91	22.30	56.30	N81° 58' 39"E	21.05	4984.86	10289.67	4987.80	10310.50
C53	27.54	35.96	43.88	N87° 50' 22"E	26.88	4987.80	10310.50	4988.81	10337.35
C54	20.91	28.90	41.46	N85° 30' 40"W	20.47	4993.11	10333.17	4994.71	10312.77
C55	5.76	28.90	11.41	N59° 04' 33"W	5.75	4994.71	10312.77	4997.67	10307.84
C56	4.56	24.89	10.50	N46° 27' 19"W	4.56	4997.67	10307.84	5000.81	10304.54

SHEET NOTES

- 1. SEE ADDITIONAL CURVE TABLES ON SHEET L3.3.
- 2. PATHWAYS SHOULD BE CONSTRUCTED IN ACCORDANCE WITH ADA STANDARDS.

Twain Harte Meadows Park  
 22945 Meadow Drive, Twain Harte, CA, 95383

DATE: PROJECT NO.

REVISION	DATE
1 60% DRAFT TO CSD	05.31.22
2 60% TO CSD	06.15.22
3 60% TO SWB	07.28.22
4 100% TO CSD	12.14.22
5 100% TO CSD	04.28.23
6 100% TO CSD	06.07.23

DESIGN BY: ABR  
 DRAWN BY: MS, JS, DR  
 REVIEW BY: RH, NS, JPB

© 2023 Watershed Progressive. The design ideas and plans represented by these documents are the property of Watershed Progressive. Use or copy is permitted by contract only. The use or revisions of these ideas or plans is prohibited without the written permission of Watershed Progressive.

LAYOUT PLAN

L3.2

100% CD

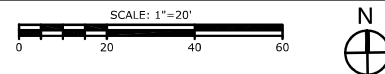

Curve Table									
Curve #	Length	Radius	Delta	Chord Direction	Chord Length	Start Northing	Start Easting	End Northing	End Easting
C57	7.44	24.89	17.12	N32° 38' 38"W	7.41	5000.81	10304.54	5007.05	10300.54
C58	15.04	24.89	34.62	N6° 46' 20"W	14.82	5007.05	10300.54	5021.76	10298.79
C62	19.58	333.67	3.36	N64° 26' 31"E	19.60	5080.83	10216.27	5089.28	10233.93
C63	16.66	333.67	2.86	N61° 19' 50"E	16.69	5089.28	10233.93	5097.27	10248.54
C64	29.44	64.99	25.95	N41° 04' 08"E	29.21	5097.27	10248.54	5119.27	10267.72
C65	17.27	64.99	15.23	N20° 28' 39"E	17.22	5119.27	10267.72	5135.41	10273.74
C66	3.83	3.00	73.10	N23° 41' 17"W	3.57	5135.41	10273.74	5138.68	10272.31
C67	3.83	3.00	73.10	S83° 12' 34"W	3.57	5138.68	10272.31	5138.26	10268.76
C71	8.16	3.00	155.75	S31° 13' 01"E	5.87	5085.85	10213.23	5080.83	10216.27
C32	2.64	3.00	50.51	S21° 24' 21"W	2.60	5159.71	10291.49	5157.33	10290.56
C33	2.64	3.00	50.51	S29° 05' 58"E	2.56	5157.33	10290.56	5155.09	10291.80
C34	11.81	71.25	9.49	S59° 12' 55"E	11.80	5155.09	10291.80	5149.06	10301.94
C35	13.21	71.25	10.62	S69° 16' 25"E	13.20	5149.06	10301.94	5144.39	10314.27
C36	8.33	71.25	6.70	S77° 56' 10"E	8.33	5144.39	10314.27	5142.65	10322.42
C37	30.63	32.80	53.50	S47° 58' 48"E	29.55	5135.56	10361.36	5115.80	10383.30
C38	9.48	5.84	92.91	S86° 30' 34"E	8.47	5071.52	10382.83	5071.00	10391.28
C39	6.39	5.84	62.65	S8° 43' 46"E	6.08	5071.00	10391.28	5065.00	10392.21
C40	0.00	5.84	0.00	S22° 35' 55"W	0.00	5065.00	10392.21	5065.00	10392.21
C42	7.12	9.64	42.30	S38° 57' 57"E	6.96	5064.99	10392.22	5059.58	10396.59
C43	8.02	69.10	6.65	S21° 09' 05"E	8.02	5059.58	10396.59	5052.10	10399.49

Curve Table									
Curve #	Length	Radius	Delta	Chord Direction	Chord Length	Start Northing	Start Easting	End Northing	End Easting
C44	10.67	22.01	27.79	S12° 18' 46"E	10.57	5052.10	10399.49	5041.78	10401.74
C45	28.10	22.01	73.15	S38° 09' 18"W	26.24	5041.78	10401.74	5021.16	10385.54
C46	42.28	91.61	26.44	S60° 12' 02"W	41.92	5021.16	10385.54	5000.33	10349.17
C12	14.84	176.26	4.82	N81° 06' 23"W	14.83	5132.49	10339.27	5134.79	10324.61
C13	7.42	176.26	2.41	N77° 29' 20"W	7.42	5134.79	10324.61	5136.39	10317.37
C14	7.42	176.26	2.41	N75° 04' 38"W	7.42	5136.39	10317.37	5138.30	10310.20
C15	9.19	25.83	20.39	N83° 48' 35"W	9.15	5138.30	10310.20	5139.29	10301.11
C16	16.43	25.83	36.43	S67° 46' 59"W	16.19	5139.29	10301.11	5133.18	10286.16
C17	19.04	25.83	42.23	S28° 27' 19"W	18.61	5133.18	10286.16	5116.82	10277.29
C18	20.26	25.83	44.92	S15° 07' 15"E	19.75	5116.82	10277.29	5097.76	10282.44
C9	18.01	91.24	11.31	S30° 33' 59"E	18.00	5097.76	10282.44	5082.28	10291.59
C10	50.30	91.24	31.59	S9° 07' 00"E	49.66	5082.28	10291.59	5033.24	10299.45
C7	46.84	75.78	35.41	S12° 17' 56"E	46.09	5078.62	10283.65	5033.59	10293.46
C1	14.87	30.19	28.23	N47° 02' 25"W	14.74	5078.62	10283.65	5088.66	10272.87
C2	19.85	30.19	37.67	N79° 59' 17"W	19.51	5088.66	10272.87	5092.05	10253.67
C3	8.44	30.19	16.02	S73° 10' 03"W	8.43	5092.05	10253.67	5089.61	10245.62
C4	31.15	392.00	4.55	S62° 50' 55"W	31.18	5089.61	10245.62	5075.40	10217.90
C5	7.41	392.00	1.08	S60° 01' 49"W	7.41	5075.40	10217.90	5071.69	10211.48

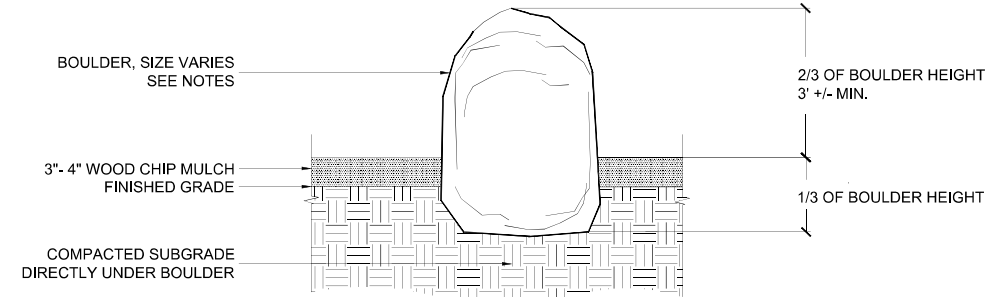

- NOTES:
1. DETAIL APPLIES TO BOULDERS THAT ARE 1' IN DIAMETER OR GREATER.
  2. BOULDERS SHALL BE FREE OF CRUMBLING, SHARP CORNERS, OPEN CRACKS OR HOLES. GRIND SMOOTH FOR SHARP CORNERS. BOULDERS SHALL BE SET FIRMLY INTO THE SOIL SO THAT THEY WILL NOT ROLL, ROTATE, OR SETTLE.
  3. CONTRACTOR MAY USE ON-SITE BOULDERS. IF ANY ADDITIONAL BOULDERS ARE REQUIRED, FINAL BOULDER SELECTION TO BE APPROVED BY OWNER'S REPRESENTATIVE. MARK OR TAG SPECIMEN BOULDERS AT SUPPLY YARD. OWNER'S REPRESENTATIVE WILL VISIT SUPPLY YARD AND INDICATE WHICH BOULDER IS APPROVED.
  4. PLACEMENT OF BOULDERS WILL BE DIRECTED IN THE FIELD BY OWNER'S REPRESENTATIVE.
  5. DO NOT COMPACT SOIL IN PLANTING BEDS.

**2 BOULDER \***  
NOT TO SCALE

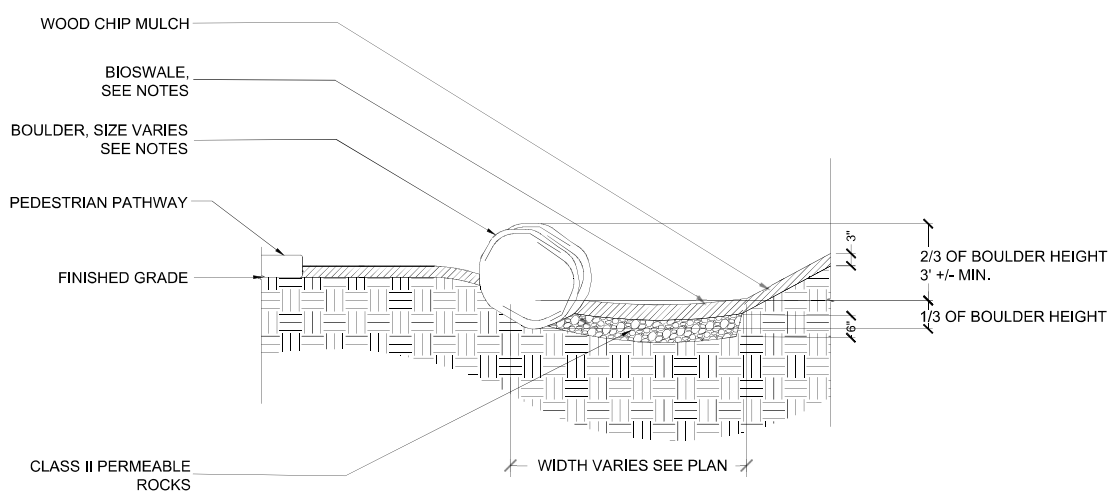

- NOTES:
1. DETAIL APPLIES TO BOULDERS THAT ARE 1' IN DIAMETER OR GREATER.
  2. LAYOUT OF DRY CREEK AND BOULDERS TO BE APPROVED BY OWNER'S REPRESENTATIVE IN THE FIELD PRIOR TO INSTALLATION.
  3. INFILTRATION AREAS SHOULD BE EXCAVATED AND CONSTRUCTED WITH AN EXCAVATOR OPERATING OUTSIDE THE AREA FOOTPRINT. EXCAVATED MATERIAL SHOULD BE PLACED AWAY FROM THE OPEN EXCAVATION.
  4. ADJACENT TRADITIONAL CONCRETE CONSTRUCTION TO OCCUR AFTER BASE COURSE PLACEMENT IS COMPLETE TO PROVIDE SUITABLE WORKING SURFACE FOR FORMS.
  5. CONTRACTOR TO PROTECT BASE COURSE BY TEMPORARILY COVERING WITH PLASTIC SHEETING DURING ADJACENT CONVENTIONAL CONCRETE CONSTRUCTION.

**3 BOULDERS IN BIOSWALE \***  
NOT TO SCALE



WATERSHED PROGRESSIVE  
WWW.WATERSHEDPROGRESSIVE.COM  
209.732.0018  
CENTRAL SIERRA OFFICE  
18653 MARIN STREET  
GROVELAND, CALIFORNIA 95321  
OJAI OFFICE  
206 N. SIGNAL ST., SUITE 3  
OJAI, CALIFORNIA 93023



Twain Harte Meadows Park  
22945 Meadow Drive, Twain Harte, CA, 95383

REVISION	DATE
1 60% DRAFT TO CSD	05.31.22
2 60% TO CSD	06.15.22
3 60% TO SWB	07.28.22
4 100% TO CSD	12.14.22
5 100% TO CSD	04.28.23
6 100% TO CSD	06.07.23

DESIGN BY: ABR  
DRAWN BY: MS, JS, DR  
REVIEW BY: RH, NS, JPB

© 2023 Watershed Progressive. The design ideas and plans represented by these documents are the property of Watershed Progressive. Use or copy is permitted by contract only. The use or revisions of these ideas or plans is prohibited without the written permission of Watershed Progressive.

**MATERIALS DETAILS**

**L3.3**



WATERSHED PROGRESSIVE  
 WWW.WATERSHEDPROGRESSIVE.COM  
 209.752.0018  
 CENTRAL SIERRA OFFICE  
 1853 MAIN STREET  
 GROVELAND, CALIFORNIA 95321  
 OJAI OFFICE  
 206 N. SIGNAL ST., SUITE 5  
 OJAI, CALIFORNIA 93023



Twain Harte Meadows Park  
 22945 Meadow Drive, Twain Harte, CA, 95383

DATE:  
PROJECT NO.

REVISION	DATE
1 60% DRAFT TO CSD	05.31.22
2 60% TO CSD	06.15.22
3 60% TO SWB	07.28.22
4 100% TO CSD	12.14.22
5 100% TO CSD	04.28.23
6 100% TO CSD	06.07.23

DESIGN BY: ABR  
 DRAWN BY: MS, JS, DR  
 REVIEW BY: RH, NS, JPB

© 2023 Watershed Progressive. The design ideas and plans represented by these documents are the property of Watershed Progressive. Use or copy is permitted by contract only. The use or revisions of these ideas or plans is prohibited without the written permission of Watershed Progressive.

MATERIALS  
DETAILS

L3.4

100% CD

NOTES:

- SEE CROSS SECTION 1 IN GRANITECRETE SPECIFICATIONS DOCUMENT.

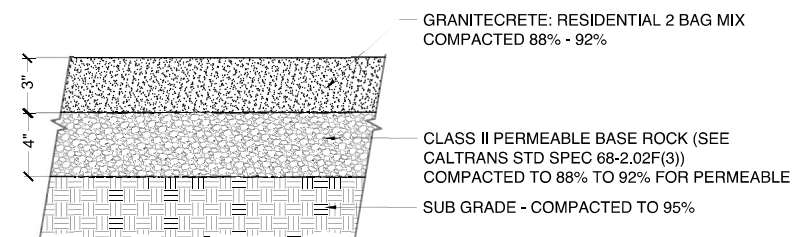

GRANITECRETE PAVING - RESIDENTIAL, PEDESTRIAN

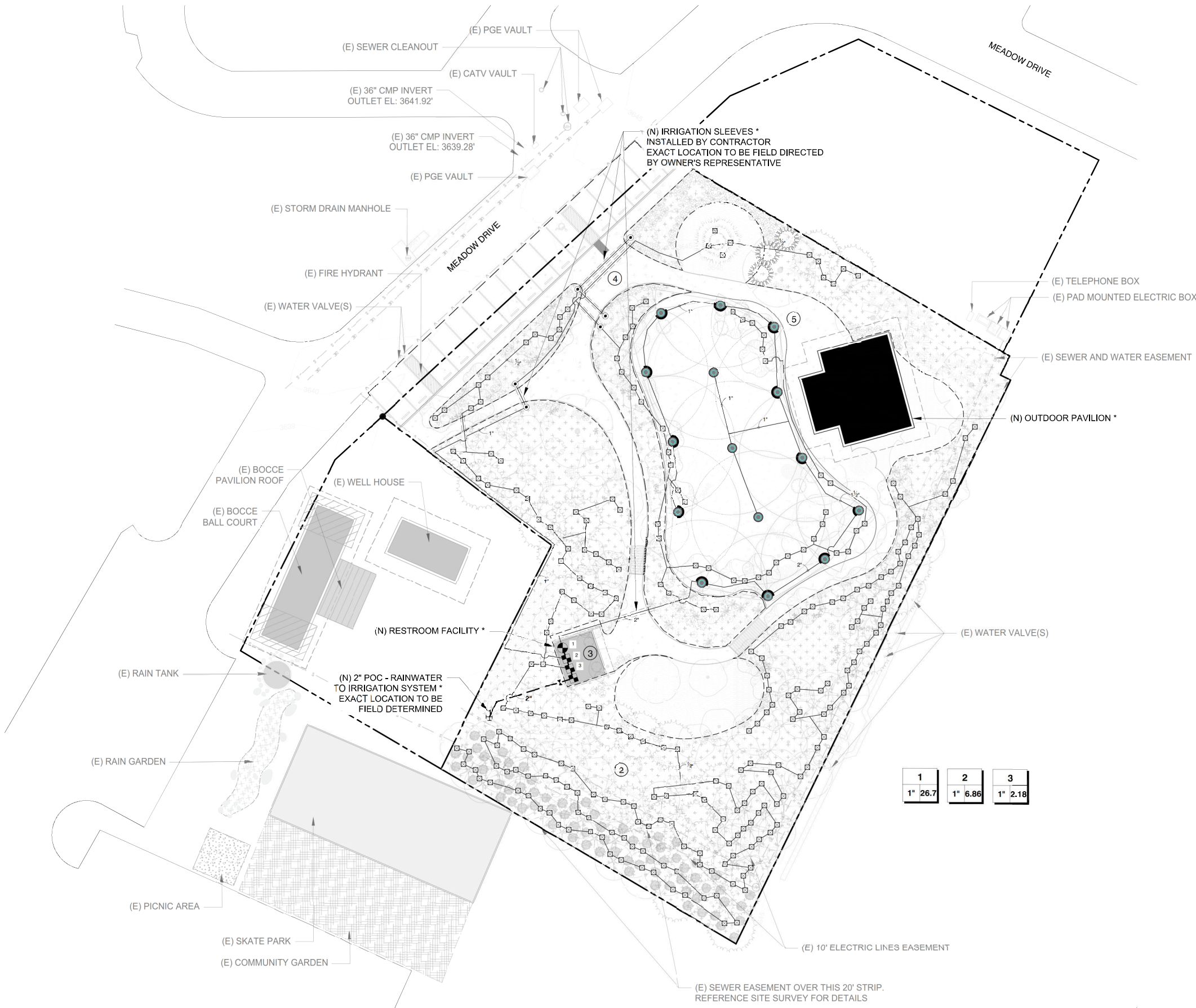

**GENERAL NOTES**

A. ALL EXISTING ACTIVE UTILITIES WORK SHALL BE AVOIDED AND PROTECTED WHEN NECESSARY THROUGHOUT CONSTRUCTION.

B. 811 - KNOW WHAT'S BELOW - CALL BEFORE YOU DIG

C. TOPOGRAPHIC DATA SHOWN IS BASED ON A SURVEY CONDUCTED BY DAVID H. RAGLAND ENGINEERING AND LAND SURVEYING IN MAY 2022. THE ELEVATIONS SHOWN ON THIS SHEET ARE REFERENCED TO AN ELLIPSOID GPS OBSERVATION. THE CONVERSION FROM THIS DATUM TO NAVD88 IS -4 FT AT TWAIN HARTE MEADOWS PARK.



- LEGEND**
- PROPERTY BOUNDARY
  - 1795- EXISTING CONTOURS
  - █ EXISTING BUILDING
  - █ PROPOSED BUILDING
  - - - BUILDING OFFSET
  - W - WATER
  - UE - UNDERGROUND ELECTRIC
  - SS - 6" SANITARY SEWER
  - ~ PIPE BREAK / CONTINUATION
  - TREE EMITTERS - VALVE 3
  - ▤ DRIP EMITTER IRRIGATION AREA - VALVE 2
  - ⊗ IRRIGATION VALVES
  - PIPE TRANSITION POINT
  - POP-UP MP ROTATORS OR APPROVED EQUAL- VALVE 1
  - ⊘ SHUT OFF VALVE - IRRIGATION
  - IRRIGATION LATERAL LINE
  - \* - - - IRRIGATION MAIN LINE
  - \* - - - SLEEVE UNDER PATHWAYS
  - POC-1 IRRIGATION POINT OF CONNECTION
  - (E) EXISTING
  - (N) NEW

- SHEET NOTES**
- \* 1. IRRIGATION SYSTEM LAYOUT AND INSTALLATION TO BE FIELD DIRECTED BY OWNERS REPRESENTATIVE.
  2. INSTALLATION OF DRIP EMITTERS BY OTHERS: INSTALL DRIP EMITTERS QUANTITIES AS SPECIFIED IN IRRIGATION SCHEDULE BY PLANT SIZE.
  3. INSTALLATION OF IRRIGATION VALVES BY OTHERS: INSTALL JUMBO VALVE BOX IN GROUND. REFERENCE IRRIGATION DETAILS FOR SPECIFICATIONS.
  - \* 4. INSTALLATION OF PIPE SLEEVES UNDER PATHWAYS BY CONTRACTOR AS SPECIFIED IN PLAN, SCHEDULE AND SPECIFICATIONS.
  5. ADJUST POP-UP SPRAY PATTERNS AFTER INSTALLATION TO MINIMIZE OVER SPRAY ON PATHWAYS BY OTHERS.

1	2	3
1" 26.7	1" 6.86	1" 2.18

Twain Harte Meadows Park  
 22945 Meadow Drive, Twain Harte, CA, 95383

DATE: PROJECT NO.

REVISION	DATE
1 60% DRAFT TO CSD	05.31.22
2 60% TO CSD	06.15.22
3 80% TO SWB	07.28.22
4 100% TO CSD	12.14.22
5 100% TO CSD	04.28.23
6 100% TO CSD	06.07.23

DESIGN BY: MS  
 DRAWN BY: MS  
 REVIEW BY: JPB

© 2023 Watershed Progressive. The design ideas and plans represented by these documents are the property of Watershed Progressive. Use or copy is permitted by contract only. The use or revisions of these ideas or plans is prohibited without the written permission of Watershed Progressive.

**IRRIGATION PLAN**

**L4.1**

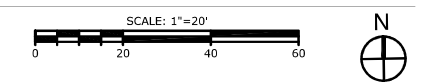

IRRIGATION BID NOTES

- \* 1. CONTRACTOR RESPONSIBLE FOR THE INSTALLATION OF UNDERGROUND UTILITIES FOR IRRIGATION CONVEYANCE TO MARKED POINT OF CONNECTIONS AS SHOWN ON IRRIGATION PLAN. INCLUDING BUT NOT LIMITED TO TRENCH WORK, EXCAVATION, PIPE BEDDING, PIPE LAYING AND COORDINATION WITH OWNER'S REPRESENTATIVE.
- \* 2. CONTRACTOR RESPONSIBLE FOR FURNISHING AND INSTALLING ALL PERTINENT MATERIALS AS SHOWN AND SPECIFIED ON IRRIGATION SCHEDULE: EQUIPMENT, FITTINGS, APPURTENANCES ASSOCIATED WITH IRRIGATION, AND UNDERGROUND POINT OF CONNECTIONS.
- \* 3. CONTRACTOR IS RESPONSIBLE FOR COORDINATING ANY IRRIGATION EQUIPMENT SUBSTITUTIONS WITH THE APPROVALS BY THE OWNER'S REPRESENTATIVE.
- \* 4. CONTRACTOR TO INSTALL AND COORDINATE ALL POINT OF CONNECTIONS STUB-OUTS ABOVE GROUND AS SHOWN ON IRRIGATION PLAN WITH OWNER'S REPRESENTATIVE.
- 5. INSTALLATION OF ABOVE GROUND IRRIGATION EQUIPMENT (EMITTERS, VALVES, VALVE BOXES, ROTORS) BY OTHERS.

IRRIGATION EQUIPMENT SCHEDULE

SYMBOL	MANUFACTURER/MODEL/DESCRIPTION	QTY	PSI
	HUNTER MP3000 PROS-06-PRS40-CV-R OR APPROVED EQUIVALENT TURF ROTATOR, 12IN. POP-UP WITH FACTORY INSTALLED CHECK VALVE, RECLAIMED BODY CAP, PRESSURE REGULATED TO 40 PSI, MP ROTATOR NOZZLE ON PRS40 BODY. ARCS 90-210, 210-270, 360.	15	40
	RAIN BIRD XCZ-100-IVM 1" OR APPROVED EQUIVALENT WIDE FLOW IVM DRIP CONTROL KIT FOR COMMERCIAL APPLICATIONS. 1IN. BALL VALVE WITH 1IN. PESB IVM SMART VALVE W/ FACTORY INSTALLED IVM-SOL 0.3-20 GPM AND 1IN. PRESSURE REGULATING 40PSI FLOW-INDICATING BASKET FILTER 0.3-20 GPM	3	
	PIPE TRANSITION POINT PIPE TRANSITION POINT FROM PVC LATERAL TO DRIP EMITTER TUBING, INSTALLED IN 6" ROUND VALVE BOXES.	7	
	DRIP EMITTERS FOR TREES (DRIP WORKS) OR APPROVED EQUIVALENT 0.5 GPH, EMITTERS (2 ASSIGNED TO EACH 15 GAL. TREE) RECOMMENDED PRESSURE FROM 20 PSI-50 PSI. OPTIONAL DIFFUSER CAP MAY BE UTILIZED FOR HIGHER FLOWS AND CLOG PROTECTION.	263	
	AREA TO RECEIVE DRIP EMITTERS FLOW RATE OF 0.5 GPH, RECOMMENDED PRESSURE FROM 20 PSI-50 PSI. REFERENCE DRIP EMITTER QUANTITIES PER PLANT SIZE BELOW.	24,487 s.f.	
	EMITTER NOTES: 0.5 GPH EMITTERS (2 ASSIGNED TO EACH 1 GAL. PLANT)	892	
	0.5 GPH EMITTERS (2 ASSIGNED TO EACH 5 GAL. PLANT)	564	
	MANUFACTURER/MODEL/DESCRIPTION RAIN BIRD PEB-PRS-D-NP-HAN 2" OR APPROVED EQUIVALENT 2" INDUSTRIAL VALVE, LOW FLOW OPERATING CAPABILITY, GLOBE CONFIGURATION, WITH PRESSURE REGULATOR MODULE, AND PURPLE FLOW HANDLE FOR NON-POTABLE WATER USE.	1	
	POINT OF CONNECTION 2" RAINWATER POINT OF CONNECTION	1	
	IRRIGATION MASTER SHUT-OFF VALVE 2"	1	
	IRRIGATION LATERAL LINE: PVC SCHEDULE 40		
	POLY LATERAL LINE: 1/2" FOR DRIP EMITTERS	2,400 l.f.	
	IRRIGATION LATERAL LINE: PVC SCHEDULE 40 3/4"	100 l.f.	
	IRRIGATION LATERAL LINE: PVC SCHEDULE 40 1"	300 l.f.	
	IRRIGATION LATERAL LINE: PVC SCHEDULE 40 1 1/4"	20 l.f.	
	IRRIGATION LATERAL LINE: PVC SCHEDULE 40 1 1/2"	80 l.f.	
	IRRIGATION LATERAL LINE: PVC SCHEDULE 40 2"	140 l.f.	
	IRRIGATION MAINLINE: PVC SCHEDULE 40	80 l.f.	
	PIPE SLEEVE: PVC CLASS 200 SDR 21 SLEEVE SIZE: 2 TIMES THE DIAMETER OF PIPE OR WIRE BUNDLE WITHIN.	100 l.f.	

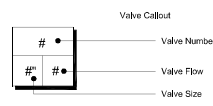

IRRIGATION NOTES

- 1. READ THOROUGHLY AND BECOME FAMILIAR WITH THE SPECIFICATIONS AND INSTALLATION DETAILS AND RELATED WORK PRIOR TO CONSTRUCTION.
- \* 2. COORDINATE UTILITY LOCATIONS ("CALL BEFORE YOU DIG - 811") PRIOR TO CONSTRUCTION.
- \* 3. AREAS, AS IDENTIFIED TO HAVE NEW IRRIGATION SYSTEM, SHALL BE INSTALLED IN CONFORMANCE WITH ALL APPLICABLE STATE AND LOCAL CODES AND ORDINANCES BY LICENSED CONTRACTORS AND EXPERIENCED WORKMEN.
- \* 4. IT IS THE RESPONSIBILITY OF THE IRRIGATION CONTRACTOR TO FAMILIARIZE THEMSELVES WITH ALL GRADE DIFFERENCES, LOCATION OF WALLS, RETAINING WALLS, EXISTING TREES ETC. CONTRACTOR SHALL REFERENCE PLAN AND SPECIFICATIONS AS NOTED, FOR THE LOCATION, SIZE AND THE INSTALLATION OF PIPE SLEEVES THROUGH WALLS, UNDER ROADWAYS, PAVING, STRUCTURES, ETC. EXACT LOCATIONS TO BE FILED DIRECTED. CONTRACTOR TO VERIFY THE LOCATION OF EXISTING UNDERGROUND UTILITIES AND STRUCTURES PRIOR TO THE EXCAVATION OF TRENCHES. CONTRACTOR TO VERIFY LOCATION OF EXISTING TREES WHERE NEW IRRIGATION IS TO BE INSTALLED. ALL EXISTING TREES SHALL BE PROTECTED AGAINST EXCAVATION DAMAGE. CONTRACTOR TO REPAIR ANY DAMAGE CAUSED BY WORK AT NO ADDITIONAL COST TO THE OWNER.
- \* 5. DUE TO THE SCALE OF THE DRAWINGS, IT IS NOT POSSIBLE TO INDICATE ALL OFFSETS, FITTINGS, SLEEVES, ETC. WHICH MAY BE REQUIRED. THE CONTRACTOR SHALL CAREFULLY INVESTIGATE THE STRUCTURAL AND FINISHED CONDITIONS AFFECTING ALL WORK AND PLAN WORK ACCORDINGLY, FURNISHING SUCH FITTINGS, ETC. AS MAY BE REQUIRED TO MEET SUCH CONDITIONS. DRAWINGS ARE GENERALLY DIAGRAMMATIC AND INDICATIVE OF THE WORK TO BE INSTALLED. THE WORK SHALL BE INSTALLED IN SUCH A MANNER AS TO AVOID CONFLICTS BETWEEN IRRIGATION SYSTEMS, PLANTING AND ARCHITECTURAL FEATURES.
- \* 6. DO NOT PROCEED WITH THE INSTALLATION OF THE IRRIGATION SYSTEM WHEN IT IS OBVIOUS IN THE FIELD THAT OBSTRUCTIONS OR GRADE DIFFERENCES EXIST THAT MIGHT NOT HAVE BEEN CONSIDERED IN THE ENGINEERING. IF DISCREPANCIES IN CONSTRUCTION DETAILS, LEGEND NOTES OR SPECIFICATIONS ARE DISCOVERED, BRING ALL SUCH OBSTRUCTIONS OR DISCREPANCIES TO THE ATTENTION OF THE OWNERS' REPRESENTATIVE.
- \* 7. IRRIGATION SYSTEM DESIGNED FOR A MINIMUM 70 PSI (STATIC PRESSURE) TO BE PROVIDED AT THE FARTHEST HEAD FROM POINT OF CONNECTION. THE IRRIGATION CONTRACTOR SHALL VERIFY WATER PRESSURE PRIOR TO CONSTRUCTION. REPORT ANY DIFFERENCE BETWEEN THE WATER PRESSURE INDICATED ON THE DRAWINGS AND THE ACTUAL PRESSURE READING AT THE IRRIGATION POINT OF CONNECTION TO THE OWNERS' AUTHORIZED REPRESENTATIVE. CONTRACTOR TO VERIFY PRESSURE ON SITE.
- \* 8. IRRIGATION POINT OF CONNECTIONS SHOWN ON PLAN MUST BE VERIFIED AT THE SITE. COORDINATE WITH EXISTING UTILITIES PLAN FOR RE-LOCATING POINT OF CONNECTION TO A LOCATION WHICH BEST SUITS SITE CONDITIONS AND IRRIGATION ZONE REQUIREMENTS.
- \* 9. SLEEVE MAINLINE AND LATERALS UNDER ALL PAVING AND WALLS. REFERENCE SCHEDULE FOR SIZE, TYPE AND QUANTITIES.
- \* 10. ALL IRRIGATION MAINLINES AND LATERALS TO BE TRENCHED AND BURIED SUB-SURFACE.
- \* 11. UN-SIZED LATERAL LINE PIPE DOWNSTREAM FROM SIZED PIPE SHALL BE 1-1/2" FOR VALVE LATERALS OR 1/2" FOR DRIP/EMITTER LATERALS.
- \* 12. SPLICING OF 24-VOLT WIRES WILL NOT BE PERMITTED EXCEPT IN VALVE BOXES. LEAVE A 24" COIL OF EXCESS WIRE AT EACH SPLICE AND 100 FEET ON CENTER ALONG WIRE RUN. TAPE WIRE IN BUNDLES 10 FEET ON CENTER. NO TAPING PERMITTED INSIDE SLEEVES.
- \* 13. ALL MAIN LINES SHALL BE FLUSHED PRIOR TO THE INSTALLATION OF IRRIGATION EQUIPMENT. AT 30 DAYS AFTER INSTALLATION EACH SYSTEM SHALL BE FLUSHED TO ELIMINATE GLUE AND DIRT PARTICLES FROM THE LINES.
- \* 14. NOTIFY OWNER'S REPRESENTATIVE OF ANY ASPECTS OF LAYOUT THAT WILL PROVIDE INCOMPLETE OR INSUFFICIENT WATER COVERAGE OF PLANT MATERIAL AND DO NOT PROCEED UNTIL THE INSTRUCTIONS ARE OBTAINED.
- \* 15. ALL EXCAVATIONS ARE TO BE FILLED WITH COMPACTED BACKFILL. BACKFILL SHALL BE PLACED IN UNIFORM LAYERS NOT TO EXCEED 8" LOOSE DEPTH, AND COMPACTED TO A MINIMUM OF 95 PERCENT OF STANDARD MAXIMUM DENSITY (ASTM D 698). CONTRACTOR TO REPAIR ALL SETTLED TRENCHES PROMPTLY.
- 16. OPERATE IRRIGATION BETWEEN THE HOURS OF 10:00 PM AND 8:00 AM AND/OR PER AVAILABLE EXISTING SCHEDULE WITHIN THE HOURS SPECIFIED.
- \* 17. 2" RAINWATER LINE TO BE USED AS IRRIGATION POINT OF CONNECTION / MAIN LINE.
- \* 18. PROVIDE THE FOLLOWING COMPONENTS TO THE OWNER PRIOR TO THE COMPLETION OF THE PROJECT:
  - I. OPERATING KEYS/CONTROL MEASURE FOR EACH OPERATED VALVE(S).
  - II. SERVICING WRENCH OR TOOL NEEDED FOR COMPLETE ACCESS, ADJUSTMENT, AND REPAIR OF ALL VALVES/IRRIGATION EQUIPMENT.
- \* 19. TO BE NOTED: PRESSURE REGULATING DEVICES ARE REQUIRED IF WATER PRESSURE IS BELOW OR EXCEEDS THE RECOMMENDED PRESSURE OF THE SPECIFIED IRRIGATION DEVICES.
- \* 20. TO BE NOTED: DUE TO GRADE AND ELEVATION CONSTRAINTS, CHECK VALVES OR ANTI-DRAIN VALVES ARE REQUIRED ON ALL NODES WHERE LOW POINT DRAINAGE COULD OCCUR.
- \* 21. TO BE NOTED: REGARDING PIPE SIZING - IF A SECTION OF UN-SIZED PIPE IS LOCATED BETWEEN THE IDENTICALLY SIZED SECTIONS, THE UN-SIZED PIPE IS THE SAME NOMINAL SIZE AS THE TWO SIZED SECTIONS. THE UN-SIZED PIPE SHOULD NOT BE CONFUSED WITH THE DEFAULT PIPE SIZE NOTED IN THE LEGEND.
- 22. TO BE NOTED: AREAS TO RECEIVE DRIP LINE/GRID SHALL HAVE DRIP TUBE FLUSH VALVES AT THE LOWEST ELEVATION RELATIVE TO THE IRRIGATION VALVE POINT OF CONNECTION AND DRIP TUBE AIR RELIEF VALVES AT THE HIGHEST POINT RELATIVE TO THE IRRIGATION VALVE POINT OF CONNECTION.
- 23. ALL POINT SOURCE EMITTER POLY LINES SHALL ALSO RECEIVE FLUSH VALVES AND AIR VALVES RELATIVE TO THE IRRIGATION VALVE POINT OF CONNECTION.
- \* 24. REFER TO PLANTING PLAN FOR PLANT MATERIAL NAMES, ABBREVIATIONS, SPECIFIC SIZES, ON-CENTER SPACING, AND ADDITIONAL INFORMATION.
- \* 25. DO NOT INSTALL DRIP LINE TUBING UNDER PAVED SURFACES. CONNECT DRIP LINE TUBING TO SCHEDULE 40 PVC LATERAL LINE PIPING FOR ROUTING UNDER PAVED SURFACES AND SCHEDULE 80 PVC PIPING FOR ROUTING THROUGH PLANTER WALLS. ADAPT DRIP LINE TUBING TO PVC PIPING AS REQUIRED WITH COMPRESSION ADAPTER FITTINGS.
- 26. REFERENCE PIPE TRANSITION POINTS FOR ADAPTING PVC TO DRIP TUBING AND POLY TUBING FOR EMITTERS.
- \* 27. MANUAL SHUT OFF VALVES SHALL BE REQUIRED AND INSTALLED AT EACH POINT OF CONNECTION PRIOR TO IRRIGATION VALVE MANIFOLD.



Twain Harte Meadows Park  
22945 Meadow Drive, Twain Harte, CA, 95383

DATE:	
PROJECT NO.	
REVISION	DATE
1 60% DRAFT TO CSD	05.31.22
2 60% TO CSD	06.15.22
3 60% TO SWB	07.28.22
4 100% TO CSD	12.14.22
5 100% TO CSD	04.28.23
6 100% TO CSD	06.07.23
DESIGN BY:	MS
DRAWN BY:	MS
REVIEW BY:	JPB

© 2023 Watershed Progressive. The design ideas and plans represented by these documents are the property of Watershed Progressive. Use or copy is permitted by contract only. The use or revisions of these ideas or plans is prohibited without the written permission of Watershed Progressive.

IRRIGATION SCHEDULE NOTES

L4.2

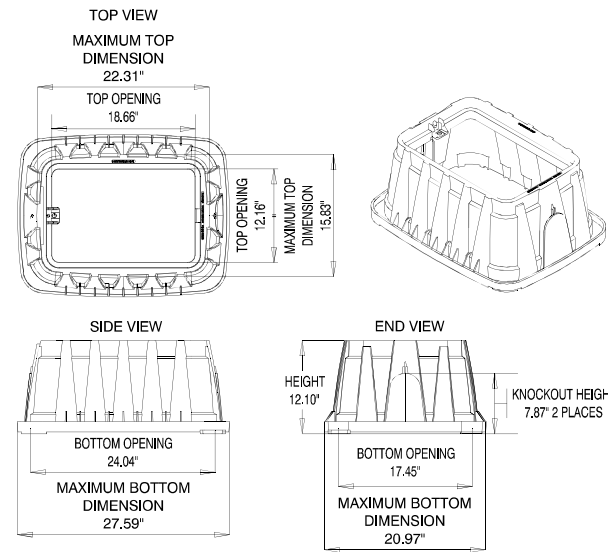

**1 RAIN BIRD JUMBO VALVE BOX DIMENSIONS OR APPROVED EQUIVALENT**  
 Not to Scale FX-IR-RB-VBOX-23

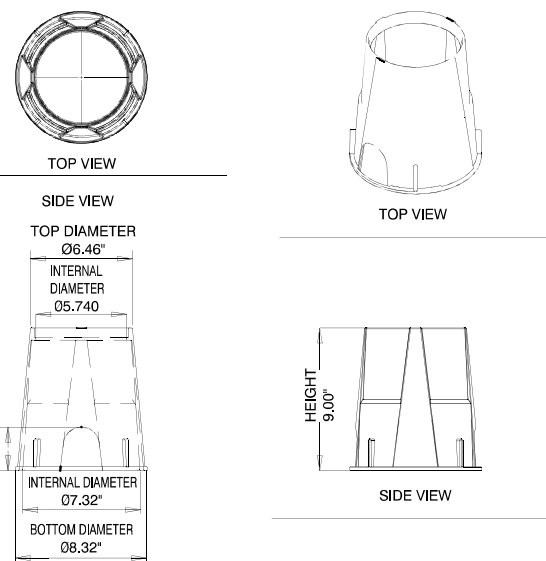

**2 RAIN BIRD 6" ROUND VALVE BOX DIMENSIONS OR APPROVED EQUIVALENT**  
 Not to Scale FX-IR-RB-VBOX-03

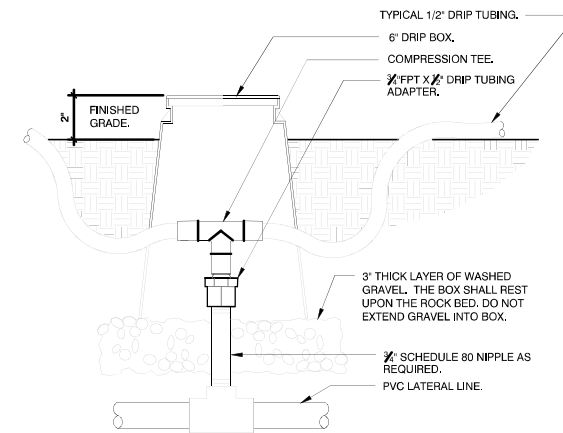

**3 ZONE CONTROL**  
 Not to Scale FX-IR-FX-DRIP-02

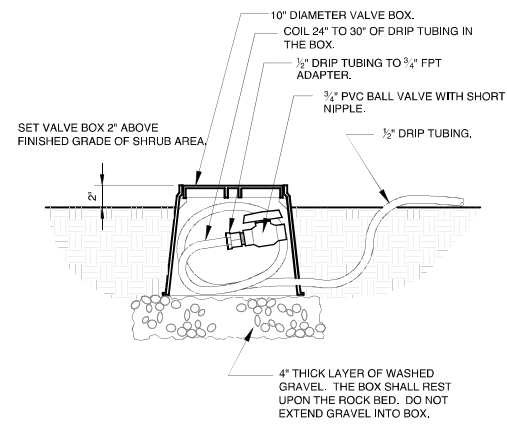

**4 DRIP IRRIGATION-EMITTER FLUSH VALVE**  
 Not to Scale

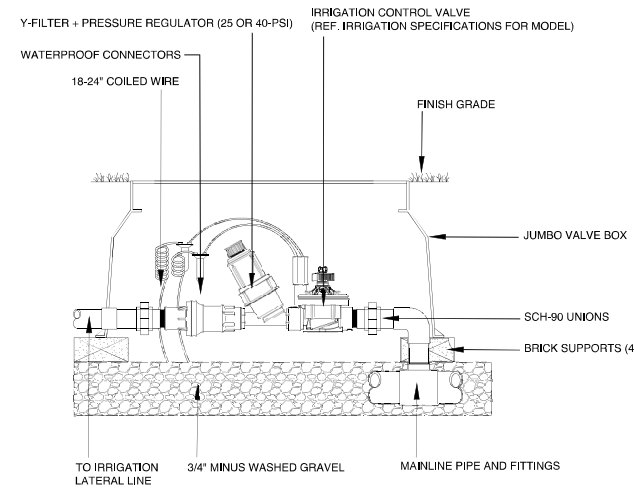

**5 IRRIGATION CONTROL VALVE W/ FILTER + UNIONS**  
 Not to Scale

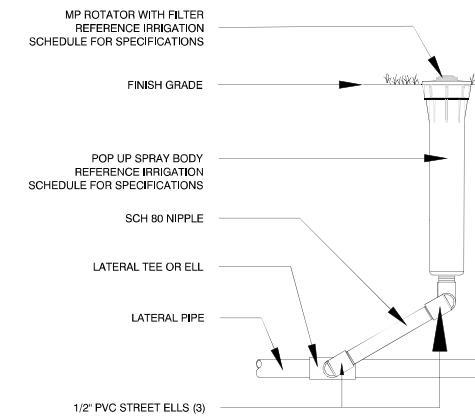

**6 MP ROTATOR WITH POP UP SPRAY BODY OR APPROVED EQUIVALENT**  
 Not to Scale

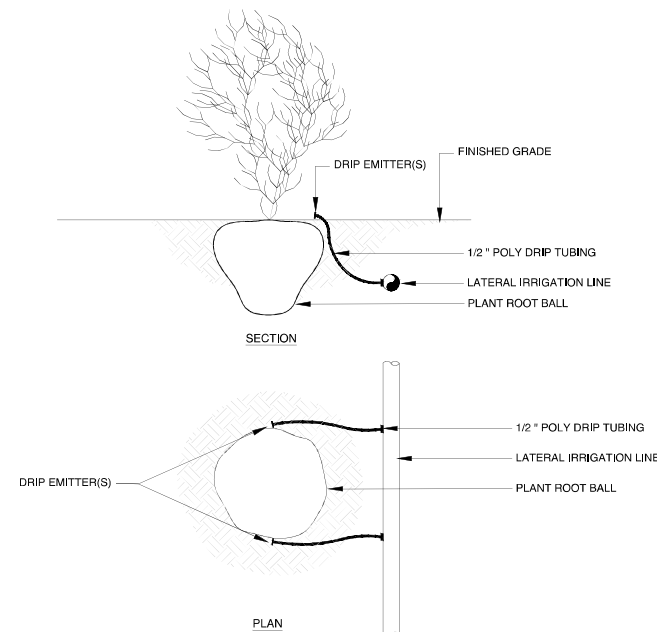

**7 DRIP EMITTER PLACEMENT (TREES, SHRUBS)**  
 Not to Scale



**MP3000-90** = 22' to 30' radius, adjustable from 90° to 210°  
**MP3000-210** = 22' to 30' radius, adjustable from 210° to 270°  
**MP3000-360** = 22' to 30' radius, 360°

**8 MP ROTATOR - 3000 SERIES OR APPROVED EQUIVALENT**  
 Not to Scale

- DETAIL NOTES:**
- NON-PRESSURIZED LINE ( IRRIGATION LATERAL LINE, WET CONVEYANCE LINE, OVERFLOW LINE)
  - PRESSURIZED LINE (MAIN LINE)
  - DETECTABLE LOCATOR TAPE
  - DIRECT BURIAL LOW VOLTAGE CONTROL WIRES
  - PIPE SLEEVE - PVC CLASS 200 SDR 21
  - FINISHED GRADE
  - PAVEMENT
  - UNDISTURBED SUB-GRADE
  - SAND BEDDING - MINIMUM 3"

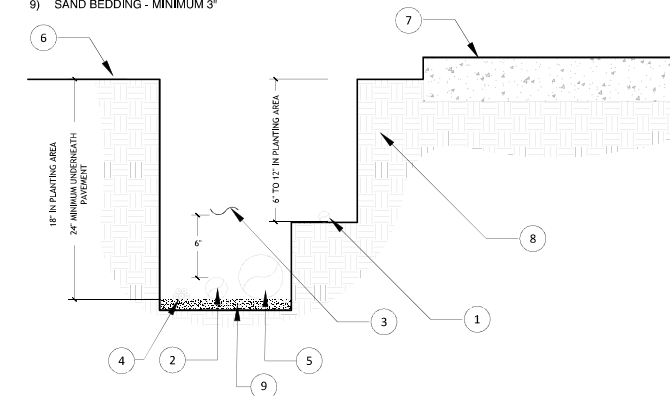

- GENERAL NOTES:**
- SEE IRRIGATION LEGEND FOR MAINLINE, LATERAL LINE, AND PIPE SLEEVE SIZES AND TYPES.
  - DIRECT BURIAL CONTROL WIRES SHALL BE INSTALLED IN SCH. 40 PVC ELECTRICAL CONDUIT IF REQUIRED.
  - 2-WIRE IRRIGATION WIRE SHALL BE INSTALLED IN SCH. 40 PVC ELECTRICAL CONDUIT.
  - DETECTABLE LOCATOR TAPE SHALL BE LOCATED SIX INCHES (6") ABOVE THE ENTIRE MAINLINE RUN.
  - FOR UTILITY TRENCHES, COMPACT THE INITIAL BACKFILL USING NATIVE SOIL TO A RELATIVE COMPACTION OF 95%.
  - FOR UNPAVED AREAS, COMPACT NATIVE SOIL MATERIAL TO A RELATIVE COMPACTION OF 85%.

**9 TRENCHING(TYP.)**  
 Not to Scale

REVISION	DATE
1	60% DRAFT TO CSD 05.31.22
2	80% TO CSD 06.15.22
3	80% TO SWB 07.28.22
4	100% TO CSD 12.14.22
5	100% TO CSD 04.28.23
6	100% TO CSD 06.07.23

DESIGN BY: MS  
 DRAWN BY: MS  
 REVIEW BY: JPB

© 2023 Watershed Progressive. The design ideas and plans represented by these documents are the property of Watershed Progressive. Use or copy is permitted by contract only. The use or revisions of these ideas or plans is prohibited without the written permission of Watershed Progressive.

**IRRIGATION DETAILS**

**L4.3**



**PLANT LEGEND**

TREES	BOTANICAL / COMMON NAME
<b>EXISTING TREES</b>	
	<i>Calocedrus decurrens</i> Incense Cedar
	<i>Pinus ponderosa</i> Ponderosa Pine
	<i>Quercus agrifolia</i> Coast Live Oak
	<i>Quercus kelloggii</i> California Black Oak
	<i>Salix spp.</i> Salix spp.
<b>PROPOSED TREES</b>	
	* <i>Abies concolor</i> White Fir
	<i>Calocedrus decurrens</i> Incense Cedar
	<i>Pinus lambertiana</i> Sugar Pine
	<i>Pinus ponderosa</i> Ponderosa Pine
	<i>Populus tremuloides</i> Quaking Aspen
<b>SHRUBS</b>	
	Existing Willow and Blackberry Thicket
	<i>Acer macrophyllum</i> Big Leaf Maple
	<i>Berberis aquifolium</i> 'Compacta' Oregon Grape
	<i>Cornus nuttallii</i> Pacific Dogwood
	<i>Corylus cornuta californica</i> Western Hazelnut
	<i>Rhododendron occidentale</i> Western Azalea
	<i>Ribes nevadense</i> Sierra Currant
	<i>Rubus parviflorus</i> Thimbleberry
	<i>Sambucus nigra</i> Black Elderberry
	<i>Symphoricarpos albus</i> Common White Snowberry
<b>PERENNIALS</b>	
	<i>Achillea millefolium</i> Common Yarrow
	<i>Artemisia vulgaris</i> Mugwort
	<i>Asclepias speciosa</i> Showy Milkweed
	<i>Darmera peltata</i> Indian Rhubarb
	<i>Erythranthe cardinalis</i> Scarlet Monkeyflower
	<i>Lepachinia calycina</i> White Pitcher Sage
	<i>Lilium columbianum</i> Tiger Lily
<b>GROUNDCOVERS</b>	
	<i>Ceanothus prostratus</i> Pine Mat
	<i>Sisyrinchium angustifolium</i> Narrowleaf Blue-eyed Grass

**GENERAL NOTES**

- A. ALL EXISTING ACTIVE UTILITIES WORK SHALL BE AVOIDED AND PROTECTED WHEN NECESSARY THROUGHOUT CONSTRUCTION.
- B. 811 - KNOW WHAT'S BELOW - CALL BEFORE YOU DIG
- D. TOPOGRAPHIC DATA SHOWN IS BASED ON A SURVEY CONDUCTED BY DAVID H. RAGLAND ENGINEERING AND LAND SURVEYING IN MAY 2022. THE ELEVATIONS SHOWN ON THIS SHEET ARE REFERENCED TO AN ELLIPSOID GPS OBSERVATION. THE CONVERSION FROM THIS DATUM TO NAVD88 IS -4 FT AT TWAIN HARTE MEADOWS PARK.

**PLANT MIXES**

Meadow Plant Mix (Refer to Table Below)

MEADOW PLANT MIX	
<b>GRASS/RUSH/SEDGE</b>	
<i>Carex praegracilis</i>	Clustered Field Sedge
<i>Melica californica</i>	California Melicgrass
<i>Muhlenbergia rigens</i>	Deer Grass
<b>WILDFLOWER SEED MIX (Possible Species)</b>	
<b>PERENNIALS</b>	
<i>Achillea millefolium</i>	Common Yarrow
<i>Asclepias speciosa</i>	Showy Milkweed
<i>Carethraoyne filaginifolia</i>	California Aster
<i>Erysimum capitatum</i>	Sanddune Wallflower
<i>Helenium bigelovii</i>	Bigelow's Sneezeweed
<i>Lepachinia calycina</i>	White Pitcher Sage
<i>Lilium columbianum</i>	Tiger Lily
<i>Mimulus bifidus</i>	Monkey Flower
<i>Monardella villosa</i>	Coyote Mint
<i>Penstemon azureus</i>	Azure Penstemon
<i>Penstemon heterophyllus</i>	Foothill Penstemon
<i>Rudbeckia californica</i>	California Cone Flower
<b>GROUNDCOVERS</b>	
<i>Arctostaphylos Uva ursi</i>	Kinnikinnick
<i>Castilleja exserta</i>	Purple Owl's Clover
<i>Collinsia tinctoria</i>	Sticky Chinese Houses
<i>Helenium bigelovii</i>	Bigelow's Sneezeweed
<i>Heuchra spp.</i>	Coral Bells
<i>Prunella vulgaris</i>	Self Heal
<i>Sisyrinchium angustifolium</i>	Baby Blue Eyes

**LEGEND**

- PROPERTY BOUNDARY
- SANITARY SEWER
- WATER
- FENCE
- PROPOSED CONTOUR
- EDUCATIONAL SIGNAGE
- WATER VALVE
- MANHOLE
- FIRE HYDRANT
- SEWER CLEAN-OUT
- EXISTING
- NEW
- MULCH
- GRAVEL PAD
- BOULDERS
- MODULAR TANK STORAGE
- RAIN TANK



Twain Harte Meadows Park  
22945 Meadow Drive, Twain Harte, CA, 95383

REVISION	DATE
1 60% DRAFT TO CSD	05.31.22
2 60% TO CSD	06.15.22
3 60% TO SWB	07.28.22
4 100% TO CSD	12.14.22
5 100% TO CSD	04.28.23
6 100% TO CSD	06.07.23

DESIGN BY: ABR  
DRAWN BY: MS, JS, DR  
REVIEW BY: RH, NS, JPB

© 2023 Watershed Progressive. The design ideas and plans represented by these documents are the property of Watershed Progressive. Use or copy is permitted by contract only. The use or revisions of these ideas or plans is prohibited without the written permission of Watershed Progressive.

**PLANTING PLAN**

**L5.1**

100% CD

**1 PLANTING PLAN**

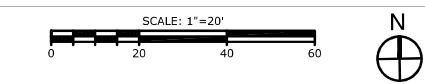













**PLANT SCHEDULE**

TREES BOTANICAL / COMMON NAME SIZE WATER NEEDS QTY

EXISTING TREES











	<i>Calocedrus decurrens</i> Incense Cedar			
	<i>Pinus Ponderosa</i> Ponderosa Pine			
	<i>Quercus agrifolia</i> Coast Live Oak			
	<i>Quercus kelloggii</i> California Black Oak			
	<i>Salix spp.</i> Salix spp.			

PROPOSED TREES

	* <i>Abies concolor</i> White Fir	15 gal.	Medium	1
	<i>Calocedrus decurrens</i> Incense Cedar	15 gal.	Low	30
	<i>Pinus lambertiana</i> Sugar Pine	15 gal.	Low	33
	<i>Pinus ponderosa</i> Ponderosa Pine	15 gal.	Low	26
	<i>Populus tremuloides</i> Quaking Aspen	15 gal.	Medium	36







SHRUBS

BOTANICAL / COMMON NAME SIZE WATER NEEDS QTY

	Existing Willow and Blackberry Thicket			
	<i>Acer macrophyllum</i> Big Leaf Maple	5 gal.	Medium	29
	<i>Berberis aquifolium</i> 'Compacta' Oregon Grape	5 gal.	Low	59
	<i>Cornus nuttallii</i> Pacific Dogwood	5 gal.	Low	6
	<i>Corylus cornuta californica</i> Western Hazelnut	5 gal.	Low	19
	<i>Rhododendron occidentale</i> Western Azalea	5 gal.	Medium	11
	<i>Ribes nevadense</i> Sierra Currant	5 gal.	Medium	117
	<i>Rubus parviflorus</i> Thimbleberry	5 gal.	Medium	25
	<i>Sambucus nigra</i> Black Elderberry	5 gal.	Low	20
	<i>Symphoricarpos albus</i> Common White Snowberry	5 gal.	Medium	18



PERENNIALS

BOTANICAL / COMMON NAME SIZE WATER NEEDS QTY

	<i>Achillea millefolium</i> Common Yarrow	1 gal.	Low	124
	<i>Artemisia vulgaris</i> Mugwort	1 gal.	Medium	16
	<i>Asclepias speciosa</i> Showy Milkweed	1 gal.	Low	20
	<i>Dermata peltata</i> Indian Rhubarb	1 gal.	Medium	7
	<i>Erythranthe cardinalis</i> Scarlet Monkeyflower	1 gal.	Medium	19
	<i>Lepachinia calycina</i> White Pitcher Sage	1 gal.	Very Low	39
	<i>Lilium columbianum</i> Tiger Lily	1 gal.	Very Low	70

GROUNDCOVERS

BOTANICAL / COMMON NAME SIZE WATER NEEDS QTY

	<i>Ceanothus prostratus</i> Pine Mat	1 gal.	Very Low	72
	<i>Sisyrinchium angustifolium</i> Narrowleaf Blue-eyed Grass	1 gal.	Low	80

**PLANT MIXES**

GROUNDCOVERS BOTANICAL / COMMON NAME SIZE WATER NEEDS QTY

	Meadow Plant Mix (Refer to Plant Mix Table Below)	Seed	Low	7,658 sf
---	--	------	-----	----------

MEADOW PLANT MIX	
<b>GRASS/RUSH/SEDGE</b>	
<i>Carex praegracilis</i>	Clustered Field Sedge
<i>Melica californica</i>	California Melicgrass
<i>Muhlenbergia rigens</i>	Deer Grass
<b>WILDFLOWER SEED MIX (Possible Species)</b>	
<b>PERENNIALS</b>	
<i>Achillea millefolium</i>	Common Yarrow
<i>Asclepias speciosa</i>	Showy Milkweed
<i>Corethrogyne filaginifolia</i>	California Aster
<i>Erysimum capitatum</i>	Sanddune Wallflower
<i>Helenium bigelovii</i>	Bigelow's Sneezeweed
<i>Lepechinia calycina</i>	White Pitcher Sage
<i>Lilium columbianum</i>	Tiger Lily
<i>Mimulus bifidus</i>	Monkey Flower
<i>Monardella villosa</i>	Coyote Mint
<i>Penstemon azureus</i>	Azure Penstemon
<i>Penstemon heterophyllus</i>	Foothill Penstemon
<i>Rudbeckia californica</i>	California Cone Flower
<b>GROUNDCOVERS</b>	
<i>Arctostaphylos Uva ursi</i>	Kinnikinnick
<i>Castilleja exserta</i>	Purple Owl's Clover
<i>Collinsia tinctoria</i>	Sticky Chinese Houses
<i>Helenium bigelovii</i>	Bigelow's Sneezeweed
<i>Heuchra spp.</i>	Coral Bells
<i>Prunella vulgaris</i>	Self Heal
<i>Sisyrinchium angustifolium</i>	Baby Blue Eyes



Twain Harte Meadows Park  
22945 Meadow Drive, Twain Harte, CA, 95383

DATE:	
PROJECT NO.	
REVISION	DATE
1 60% DRAFT TO CSD	05.31.22
2 60% TO CSD	06.15.22
3 60% TO SWB	07.28.22
4 100% TO CSD	12.14.22
5 100% TO CSD	04.28.23
6 100% TO CSD	06.07.23
DESIGN BY:	ABR
DRAWN BY:	MS, JS, DR
REVIEW BY:	RH, NS, JPB

© 2023 Watershed Progressive. The design ideas and plans represented by these documents are the property of Watershed Progressive. Use or copy is permitted by contract only. The use or revisions of these ideas or plans is prohibited without the written permission of Watershed Progressive.

**PLANT SCHEDULE**

**L5.2**

NOTES:

SITE PREPARATION

- \* 1. CONTRACTOR SHALL BE AWARE OF ALL UNDERGROUND UTILITIES, PIPES AND STRUCTURES. CONTRACTOR SHALL CONTACT ALL UTILITY COMPANIES FOR FIELD LOCATION OF UNDERGROUND UTILITY LINES PRIOR TO ANY EXCAVATION. CONTRACTOR SHALL TAKE SOLE RESPONSIBILITY OF ANY COST.
- \* 2. DO NOT PROCEED WITH CONSTRUCTION AS DESIGNED IF OBSTRUCTIONS AND/OR GRADE DIFFERENCES EXIST THAT MAY NOT HAVE BEEN KNOWN DURING DESIGN. SUCH CONDITIONS SHALL BE IMMEDIATELY BROUGHT TO THE ATTENTION OF THE OWNERS REPRESENTATIVE. THE CONTRACTOR SHALL ASSUME FULL RESPONSIBILITY FOR ALL NECESSARY REVISIONS DUE TO FAILURE TO GIVE SUCH NOTIFICATION.
- \* 3. CONTRACTOR SHALL BE RESPONSIBLE FOR ANY COORDINATION WITH SUBCONTRACTORS AS REQUIRED TO ACCOMPLISH PLANTING OPERATIONS.

SOIL PREPARATION

- 4. PRIOR TO STARTING CONSTRUCTION WORK, CONTRACTOR SHALL TAKE SOIL SAMPLES WHERE DIFFERENT SOIL TYPES ARE ENCOUNTERED ON THE PROJECT SITE. SOIL SHALL BE ANALYZED BY AN APPROVED COMMERCIAL SOIL TESTING LABORATORY (TRIC ENTERPRISES, 1-800-392-3311, OR FRUIT GROWERS LABORATORY, 805-392-2000), OR EQUAL, FOR SUITABILITY FOR ORNAMENTAL PLANTING. A COPY OF THE RESULTS OF THIS ANALYSIS SHALL BE SUBMITTED TO THE OWNER'S REPRESENTATIVE. CONTRACTOR SHALL FOLLOW THE RECOMMENDATIONS OF THE SOILS LAB AS TO THE RATE AND ANALYSIS OF FERTILIZER & AMENDMENTS TO PROVIDE A SUITABLE MEDIUM FOR PLANTING. THE CONTRACTOR SHALL NOTIFY THE OWNERS REPRESENTATIVE OF ANY POTENTIAL PROBLEMS WHICH MAY RESULT DUE TO HARMFUL SUBSTANCES FOUND IN THE SOIL. FAILURE TO ACT AS SPECIFIED MAY RESULT IN THE CONTRACTOR ASSUMING FINANCIAL RESPONSIBILITY FOR ANY DAMAGE TO PLANTS.
- \* 5. REMOVE ROCKS LARGER THAN 3" FROM PLANTING AREAS.
- \* 6. FOR SOILS LESS THAN 6% ORGANIC MATTER IN THE TOP 6 INCHES OF SOIL, COMPOST AT A RATE OF A MINIMUM OF FOUR CUBIC YARDS PER 1,000 SQUARE FEET OF PERMEABLE AREA SHALL BE INCORPORATED TO A DEPTH OF SIX INCHES INTO THE SOIL.
- \* 7. ON-SITE SOILS WITH AN ORGANIC CONTENT OF AT LEAST 5 PERCENT CAN BE PROPERLY STOCKPILED (TO MAINTAIN ORGANIC CONTENT) AND REUSED.
- \* 8. CONTRACTOR TO LOOSEN COMPACTED SOILS AND MIX SOIL AMENDMENTS AND CONDITIONERS TO A MINIMUM DEPTH OF 12 INCHES IN PLANTING AREAS.

FINISHED GRADES IN PLANTING AREAS

- \* 9. THE CONTRACTOR SHALL ALLOW FOR THE ADDITION OF SPECIFIED QUANTITIES OF SOIL AMENDMENTS AND CONDITIONERS IN SOIL PREPARATION AND FINISH GRADING.
- 10. THE OWNERS REPRESENTATIVE WILL APPROVE FINISH GRADES AT ALL LANDSCAPE AREAS PRIOR TO PLANTING.
- \* 11. THE CONTRACTOR SHALL BE RESPONSIBLE TO ESTABLISH THE SPECIFIED FINISHED ELEVATION, INCLUDING IMPORTING SOIL OR EXCAVATION, REMOVAL AND DISPOSAL AT AN APPROVED LOCATION. THE CONTRACTOR SHALL FURNISH AND INSTALL SUPPLEMENTARY AMENDED IMPORT SOIL IN ANY PLANTING AREAS AS NECESSARY TO ACHIEVE THE SPECIFIED FINISH PLANTING GRADES. IMPORTED SOIL SHALL BE FREE OF UNWANTED SEEDS.

PLANTING

- \* 12. COORDINATE INSTALLATION OF LARGE PLANT MATERIAL WITH INSTALLATION OF STRUCTURES SUCH AS WALL FOOTINGS, PAVEMENTS, AND CURB AND GUTTER. ANY DAMAGE TO IMPROVEMENTS BY OTHERS IS THE RESPONSIBILITY OF THE CONTRACTOR.
- \* 13. CONTRACTOR SHALL FURNISH PLANT MATERIAL FREE OF PESTS OR PLANT DISEASES. CONTRACTOR SHALL WARRANT ALL PLANT MATERIALS PER THE SPECIFICATIONS. THE CONTRACTOR SHALL PROVIDE HEALTHY, VIGOROUS PLANT STOCK GROWN UNDER CLIMATIC CONDITIONS SIMILAR TO THE CONDITIONS IN THE LOCALITY OF THE PROJECT.
- 14. SPECIMEN TREES WILL BE SELECTED AND TAGGED BY THE OWNERS REPRESENTATIVE PRIOR TO PLANT INSTALLATION.
- \* 15. ALL SUBSTITUTIONS SHALL BE REVIEWED AND APPROVED BY THE OWNERS REPRESENTATIVE.
- \* 16. SEE DETAILS AND SPECIFICATIONS FOR STAKING METHOD, PLANT PIT DIMENSIONS AND BACKFILL REQUIREMENTS.
- \* 17. PLANT CROWN ELEVATIONS RELATIVE TO FINISH GRADE ARE SHOWN ON PLANTING DETAILS AND SHALL BE STRICTLY ADHERED TO. PROPER COMPACTION OF BACKFILL TO PREVENT SETTLEMENT SHALL BE REQUIRED.
- \* 18. TREES AND SHRUBS SHALL BE INSTALLED PRIOR TO PLANTING GROUND COVER. ALL TREE LOCATIONS SHALL BE VERIFIED IN THE FIELD BY THE OWNERS REPRESENTATIVE.
- 19. THE OWNERS REPRESENTATIVE RESERVES THE RIGHT TO ADJUST THE LOCATION OF PLANT MATERIAL DURING INSTALLATION AS APPROPRIATE TO THE PROJECT.
- \* 20. A MINIMUM 3-INCH LAYER OF MULCH SHALL BE APPLIED ON ALL EXPOSED SOIL SURFACES OF PLANTING AREAS EXCEPT TURF AREAS, CREEPING OR ROOTING GROUND COVERS, OR DIRECT SEEDING APPLICATIONS WHERE MULCH IS CONTRA-INDICATED. MULCH MUST BE APPROVED BY THE OWNERS REPRESENTATIVE.

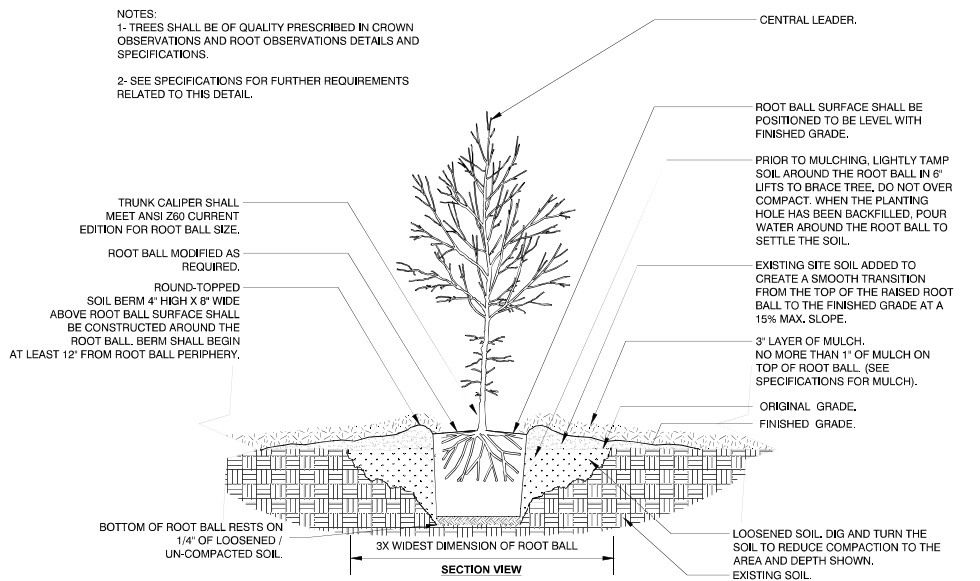

- NOTES:  
 1. TREE SHALL BE A MINIMUM OF 15-FEET IN HEIGHT AND TO BE COORDINATED WITH OWNERS REPRESENTATIVE.  
 2. TREE SHALL BE OF QUALITY PRESCRIBED IN CROWN OBSERVATIONS AND ROOT OBSERVATIONS DETAILS AND SPECIFICATIONS.  
 3. IF TREE ARRIVES WITH A WIRE BASKET AROUND THE ROOT BALL, CUT THE WIRE BASKET IN FOUR PLACES AND FOLD DOWN INTO PLANTING HOLE EXPOSING TOP HALF OF BALL. REMOVE TWINE, ROPE AND BURLAP FROM TOP HALF OF BALL.  
 4. SEE SPECIFICATIONS FOR FURTHER REQUIREMENTS RELATED TO THIS DETAIL.

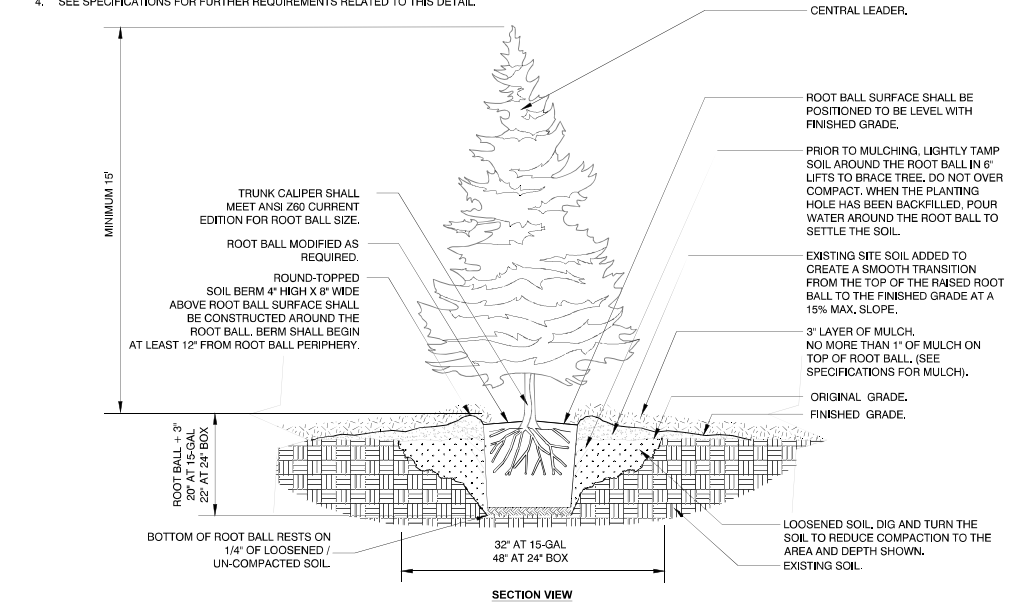

**3 TOWN CHRISTMAS TREE PLANTING**  
Not to Scale

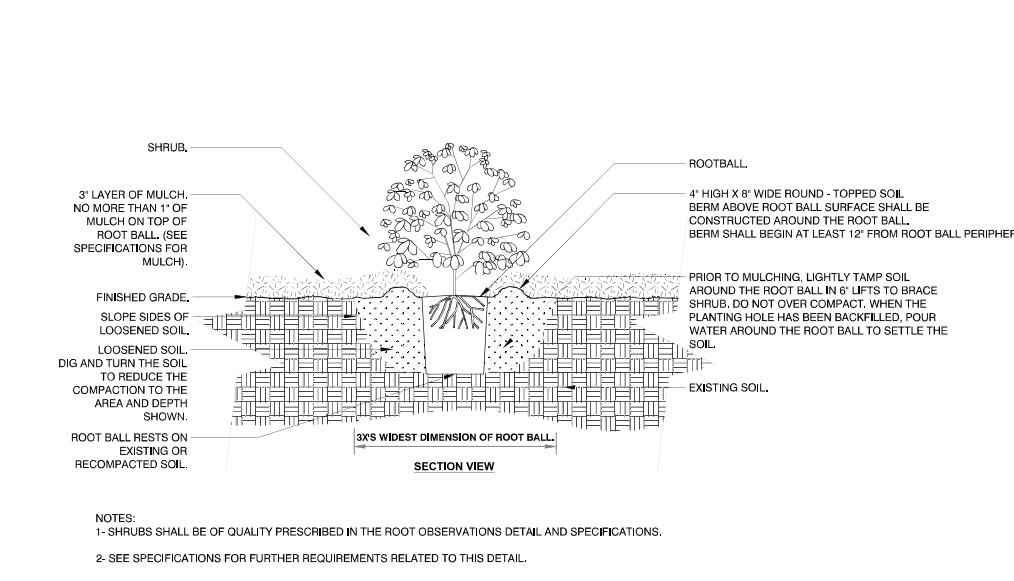

**2 SHRUB PLANTING**  
Not to Scale

Twain Harte Meadows Park  
 22945 Meadow Drive, Twain Harte, CA, 95383

DATE:  
PROJECT NO.

REVISION	DATE
1 60% DRAFT TO CSD	05.31.22
2 60% TO CSD	06.15.22
3 60% TO SWB	07.28.22
4 100% TO CSD	12.14.22
5 100% TO CSD	04.28.23
6 100% TO CSD	06.07.23

DESIGN BY: ABR  
 DRAWN BY: MS, JS, DR  
 REVIEW BY: RH, NS, JPB

© 2023 Watershed Progressive. The design ideas and plans represented by these documents are the property of Watershed Progressive. Use or copy is permitted by contract only. The use or revisions of these ideas or plans is prohibited without the written permission of Watershed Progressive.

PLANTING DETAILS

L5.3



GENERAL NOTES

- A. ALL EXISTING ACTIVE UTILITIES WORK SHALL BE AVOIDED AND PROTECTED WHEN NECESSARY THROUGHOUT CONSTRUCTION.
- B. 811 - KNOW WHAT'S BELOW - CALL BEFORE YOU DIG
- C. TOPOGRAPHIC DATA SHOWN IS BASED ON A SURVEY CONDUCTED BY DAVID H. RAGLAND ENGINEERING AND LAND SURVEYING IN MAY 2022. THE ELEVATIONS SHOWN ON THIS SHEET ARE REFERENCED TO AN ELLIPSOID GPS OBSERVATION. THE CONVERSION FROM THIS DATUM TO NAVD88 IS -4 FT AT TWAIN HARTE MEADOWS PARK.
- D. NEW COLD WATER, SEWER AND ELECTRICAL UTILITY PIPING TO MEADOWS FACILITIES SHALL BE ROUTED WITHIN TRENCH. ALL TRENCH WORK SHALL BE COORDINATED BY THE GENERAL CONTRACTOR WITH EXCAVATION, GRADING AND SITE DESIGN.

LEGEND

---	PROPERTY BOUNDARY	[Grid Pattern]	MODULAR TANK STORAGE
-1795-	EXISTING CONTOURS	[Valve Symbol]	BALL VALVE
[Grey Box]	EXISTING BUILDING	[Valve Symbol]	3-WAY DIVERTER VALVE
[Black Box]	PROPOSED BUILDING	[Wavy Line]	PIPE BREAK / CONTINUATION
---	BUILDING OFFSET	[Circle with X]	PUMP
---	TRENCH	[Circle with +]	POINT OF CONNECTION
→	RAINWATER CONVEYANCE	[Square with X]	CLEANOUT (CO-1)
⊙	DOWNSPOUT	[Arrow]	CHECK VALVE
→	OVERFLOW CONVEYANCE	[Circle]	MULCH BASIN
-w-	MUNICIPAL WATER LINE	[Triangle]	BACKFLOW PREVENTER
-e-	UNDERGROUND ELECTRIC	[Circle with Wavy]	INTERACTIVE WHEEL
-ss-	6" SANITARY SEWER	(E)	EXISTING
→	GREYWATER CONVEYANCE	(N)	NEW
[Circle]	RAIN TANK	BFF	BELOW FINISHED FLOOR (OR TOP OF SLAB ELEVATION)

SHEET NOTES

- 1. CONTRACTOR TO PROVIDE ABOVE GRADE CAPPED COLD WATER POINT OF CONNECTION WITH SHUT OFF VALVE AND CAPPED SANITARY SEWER POC WITH CLEAN OUT AT 6-FEET OUTSIDE THE BUILDING FOR FUTURE CONNECTION TO OUTDOOR SINK AND BBQ.
- 2. OTHERS TO PROVIDE FIRST FLUSH ASSEMBLY ON ALL DOWNSPOUTS. (TYP OF 4). COORDINATE WITH CONTRACTOR FOR LOCATIONS TO TIE IN AT UNDERGROUND PIPING. REFER TO SCHEDULES FOR CRITERIA. REFER TO DETAIL 1/L6.3.
- 3. CONTRACTOR TO PROVIDE NEW 4" SANITARY SEWER POINT OF CONNECTION TO EXISTING SEWER MAIN. EXACT TIE-IN LOCATION, SIZE AND INVERT TO BE FIELD VERIFIED. WHERE NEW PIPE SIZE EXCEEDS EXISTING PIPE SIZE, NOTIFY OWNER'S REPRESENTATIVE. CONFLICTS WITH EXISTING UG UTILITIES SHALL BE FIELD COORDINATED AND AVOIDED.
- 4. OTHERS TO INSTALL ENTIRETY OF GREYWATER SYSTEM FROM POINT OF CONNECTION AT RESTROOM TO MULCH BASINS. NO SCOPE OF WORK FOR CONTRACTOR INCLUDED. FOLLOW GREYWATER SPECIFICATIONS AND SYSTEM INSTALLATION NOTES ON SHEET L6.2. REFER TO DETAILS OF MULCH BASIN AND SYSTEM CONNECTIONS ON L6.5.
- 5. CONTRACTOR TO PROVIDE GUTTERS ALONG LOW POINT EDGES OF ROOF. CONTRACTOR TO PROVIDE HOLES FOR DOWNSPOUT CONNECTIONS AT LOCATIONS INDICATED ON PLANS. OTHERS TO CONNECT TO DOWNSPOUTS AND ASSOCIATED FIRST FLUSH ASSEMBLIES. CONTRACTOR TO PROVIDE UNDERGROUND RW PIPING TO SYSTEM. CONTRACTOR TO COORDINATE DOWNSPOUT LOCATION WITH UNDERGROUND PIPING CONSTRUCTION. REFER TO SCHEDULES.
- 6. OTHERS TO CONSTRUCT AND COORDINATE ENTIRETY OF UNDERGROUND TANK AND FLUME SYSTEM. CONTRACTOR SHALL PROVIDE CAPPED, LABELED STUB OUTS AT INDICATED POC LOCATIONS FOR OTHERS CONNECTION AND INSTALLATION TO SYSTEM.
- 7. SCOPE OF WORK FOR TANK-2 IS AS FOLLOWS:
  - 7.1. CONTRACTOR SHALL PROVIDE POINTS OF CONNECTION AS INDICATED ON PLANS FOR 1" RW & 1/2" CW CONNECTIONS TO TANK.
  - 7.2. CONTRACTOR TO PROVIDE TANK AND COORDINATE TANK INSTALLATION SCHEDULE WITH OWNER'S REPRESENTATIVE AND MANUFACTURER.
  - 7.3. CONTRACTOR TO COORDINATE ALL TANK PORT LOCATIONS WITH OWNER'S REPRESENTATIVE, LANDSCAPE WATER REUSE CONTRACTOR AND MANUFACTURER PRIOR TO PURCHASE.
  - 7.4. OTHERS TO INSTALL ALL FINAL PIPING TO TANK-2 INCLUDING ENTIRETY OF RW AND OVERFLOW CONVEYANCE PIPING.
- 8. OTHERS TO PROVIDE FINAL DESIGN AND SPECIFICATIONS FOR OUTDOOR SINK AND BBQ AS COORDINATED WITH CSD. THE BASIS OF DESIGN AND COST ESTIMATE INCLUDES:
  - 8.1. (1) OUTDOOR-RATED STAINLESS STEEL SCULLERY SINK
  - 8.2. (1) OUTDOOR PERMANENT CHARCOAL BBQ WITH COVER
  - 8.3. (1) ABOVE GROUND 20GPM, 40LB CAP. HYDROMECHANICAL GREASE INTERCEPTOR. JAY R SMITH 8120 OR SIMILAR
  - 8.4. FRAMING TO CONCEAL / PROTECT SINK AND INTERCEPTOR
  - 8.5. UTILITY TIE IN'S FOR SEWER/VENT, CW AND ELECTRICAL.

Twain Hart Meadows Park  
 22945 Meadow Drive, Twain Harte, CA, 95383

DATE:	PROJECT NO.
REVISION	DATE
1 60% DRAFT TO CSD	05.31.22
2 60% TO CSD	06.15.22
3 60% TO SWB	07.28.22
4 100% TO CSD	12.14.22
5 100% TO CSD	04.28.23
6 100% TO CSD	06.07.23

DESIGN BY: SS,MS  
 DRAWN BY: MS  
 REVIEW BY: JPB

WATER REUSE AND UTILITIES PLAN

L6.1

100% CD

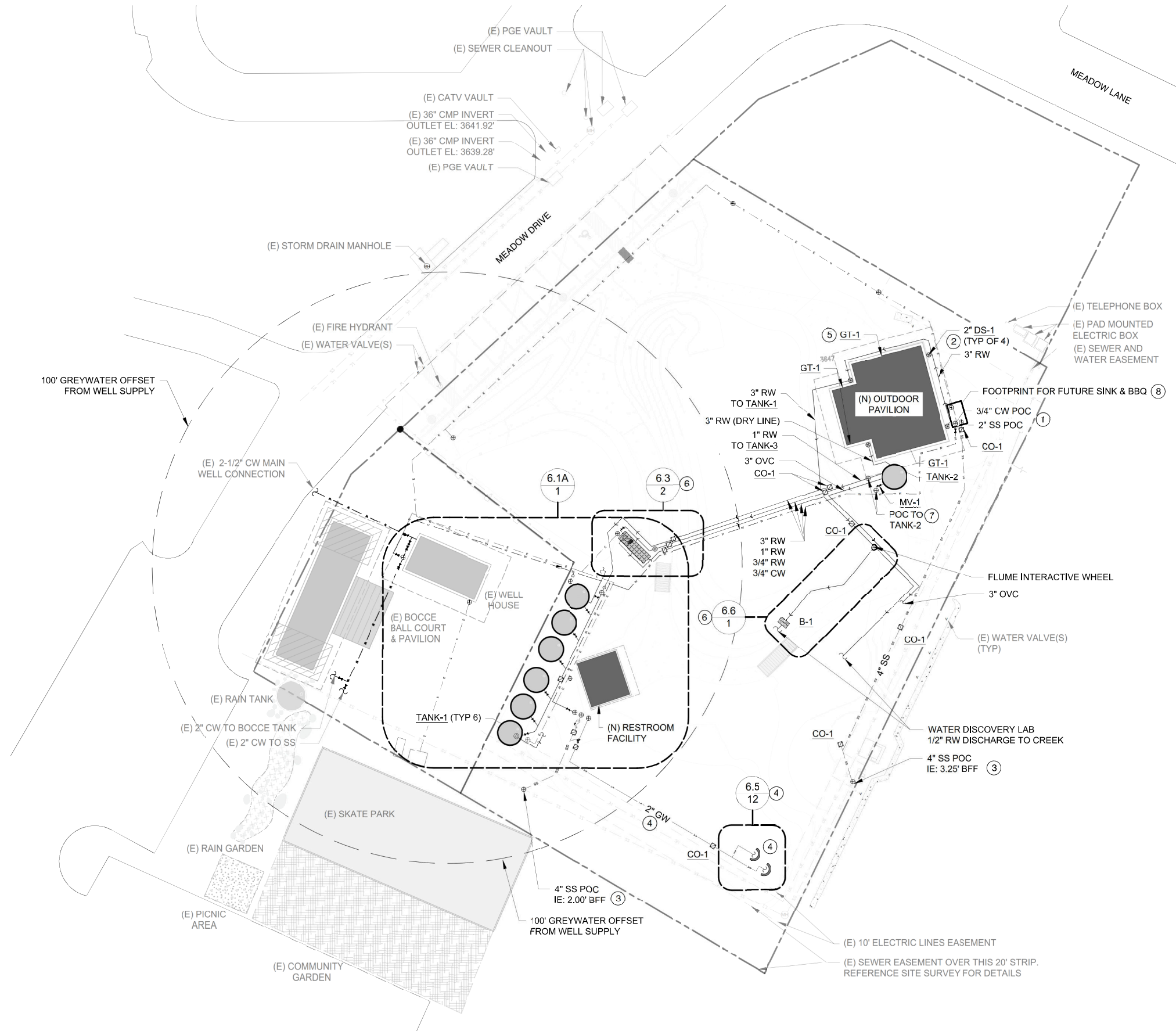

1 WATER REUSE AND UTILITIES PLAN

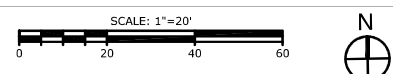

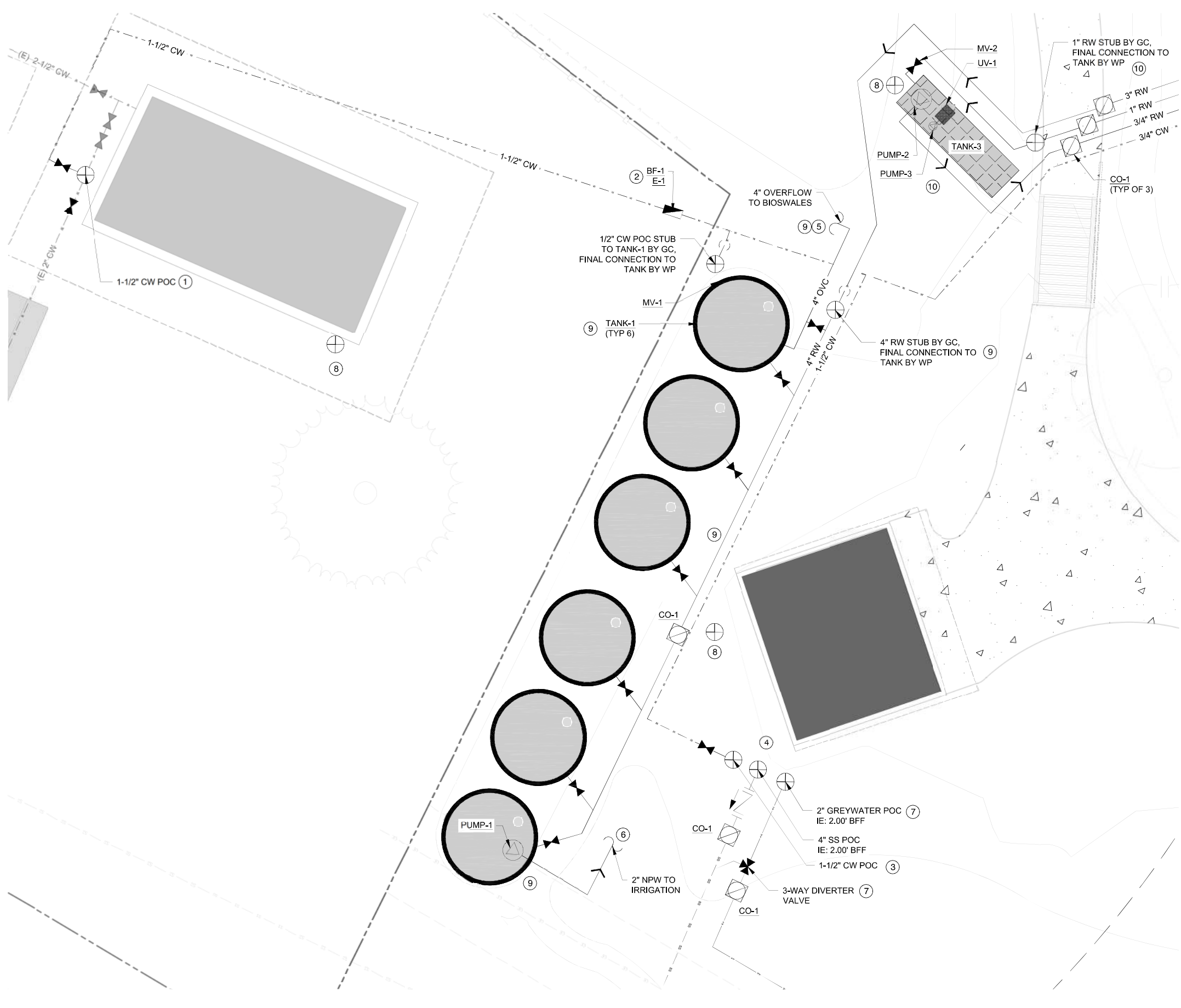

GENERAL NOTES

- A. ALL EXISTING TANKS, PIPING, AND ELECTRICAL WORK SHALL BE AVOIDED AND PROTECTED WHEN NECESSARY THROUGHOUT CONSTRUCTION.
- B. DATUM: 3645.00' ESTIMATED FROM GOOGLE EARTH AND REFERENCED TO AN ELLIPSOID GPS OBSERVATION
- C. 811 - KNOW WHAT'S BELOW - CALL BEFORE YOU DIG

SHEET NOTES

- 1. CONTRACTOR TO PROVIDE NEW 1-1/2" COLD WATER POINT OF CONNECTION TO EXISTING WELL DISTRIBUTION PIPING EXACT TIE-IN LOCATION SHALL BE FIELD VERIFIED. WHERE TIE-IN REQUIRES SYSTEM SHUT-OFF, SHUT-OFF SHALL BE COORDINATED WITH FACILITY MANAGER. PROVIDE ISOLATION VALVES DOWNSTREAM OF NEW CONNECTION ON BOTH NEW AND EXISTING COLD WATER PIPE.
- 2. CONTRACTOR TO PROVIDE BACK-FLOW PREVENTER IN SECURE ENCLOSURE IMMEDIATELY DOWNSTREAM OF CONNECTION TO WELL, PRIOR TO AND UPSTREAM OF ANY NEW OR ADDED CONNECTIONS. REFER TO DETAIL.
- 3. CONTRACTOR TO PROVIDE ABOVE GRADE CAPPED COLD WATER POINT OF CONNECTION WITH SHUT OFF VALVE AT 6-FEET OUTSIDE THE BUILDING FOR CONNECTION TO RESTROOM BUILDING.
- 4. RESTROOM MANUFACTURER SHALL INSTALL ALL UTILITY CONNECTIONS (SS, GW, CW, ELEC) INSIDE THE BUILDING TO FIXTURES. CONTRACTOR SHALL PROVIDE STUB OUT POCS TO THE BUILDING FOR COORDINATION WITH THE RESTROOM MANUFACTURER AT 6-FEET OUTSIDE THE BUILDING. CONTRACTOR TO MAKE ALL FINAL CONNECTIONS FROM THE SITE TO THE BUILDING AND ENSURE PROPER OPERATION OF ALL UTILITIES WITHIN THE BUILDING PRIOR TO RESTROOM MANUFACTURER DEPARTURE.
- 5. OTHERS TO PROVIDE SCREENED RAINWATER TANK OUTLET TO BIOSWALE. TANK OUTLETS SHALL BE PROVIDED WITH BALL-TYPE SHUT OFF VALVE LOCATED WITHIN BIOSWALE DIRECTLY UPSTREAM OF SCREENED DISCHARGE. CONTRACTOR TO PROVIDE TRENCHING. OTHERS TO MAKE FINAL CONNECTIONS. REFER TO STORMWATER PLAN FOR CONTINUATION. TANK REFER TO DETAIL 9/L6.4.
- 6. OTHERS TO PROVIDE IRRIGATION PIPING, REFER TO IRRIGATION PLAN FOR CONTINUATION.
- 7. OTHERS TO PROVIDE ENTIRETY OF GREYWATER SYSTEM. GREYWATER 3-WAY DIVERTER VALVE SHALL BE PROVIDED IN ACCORDANCE WITH CHAPTER 15 OF THE CALIFORNIA PLUMBING CODE. THE 3-WAY VALVE SHALL BE PROVIDED INSIDE THE RESTROOM UTILITY CLOSET BY THE RESTROOM MANUFACTURER. ONLY WHERE PIPING CONSTRAINTS PROHIBIT THE INSTALLATION, THE VALVE MAY BE INSTALLED AT GRADE WITH ACCESS COVER BY OTHERS (AS SHOWN ON THE DRAWINGS). COST OF 3-WAY VALVE SHALL BE INCLUDED BY OTHERS - WHERE THE VALVE IS PROVIDED BY THE RESTROOM MANUFACTURER, COST SHALL BE REFUNDED TO THE OWNER.
- 8. CONTRACTOR TO PROVIDE ELECTRICAL POINT OF CONNECTION - REFER TO L-7 SERIES.
- 9. SCOPE OF WORK FOR TANK-1 SYSTEM IS AS FOLLOWS:
  - 9.1. CONTRACTOR SHALL PROVIDE POINTS OF CONNECTION AS INDICATED ON PLANS FOR 4" RW & 1/2" CW TO TANK.
  - 9.2. CONTRACTOR TO PROVIDE ELECTRICAL POINT OF CONNECTION FOR PUMP.
  - 9.3. CONTRACTOR TO PROVIDE TANKS AND COORDINATE TANK INSTALLATION SCHEDULE WITH OTHERS AND MANUFACTURER.
  - 9.4. OTHERS TO INSTALL ALL DAISY-CHAIN PIPING, PIPING TO TANK PORTS, OVERFLOW CONVEYANCE AND PUMPED NPW PIPING.
  - 9.5. OTHERS TO INSTALL PUMP SYSTEM.
  - 9.6. OTHERS TO ENSURE FUNCTIONALITY OF A COMPLETE SYSTEM.
- 10. SCOPE OF WORK FOR TANK-3 SYSTEM IS AS FOLLOWS:
  - 10.1. CONTRACTOR SHALL PROVIDE POINTS OF CONNECTION AS INDICATED ON PLANS FOR BELOW GRADE 3" RW TO TANK.
  - 10.2. CONTRACTOR TO PROVIDE ELECTRICAL POINT OF CONNECTION FOR PUMP.
  - 10.3. OTHERS TO PROVIDE TANK AND COORDINATE TANK INSTALLATION SCHEDULE WITH CONTRACTOR AND MANUFACTURER.
  - 10.4. OTHERS TO INSTALL ALL PIPING TO TANK-3 AND PIPING FROM TANK-3 TO FLUME STRUCTURE.
  - 10.5. OTHERS TO INSTALL PUMP AND TREATMENT SYSTEM.
  - 10.6. OTHERS TO ENSURE FUNCTIONALITY OF A COMPLETE SYSTEM.



Twain Heart Meadows Park  
22945 Meadow Drive, Twain Harte, CA, 95383

REVISION	DATE
1 60% DRAFT TO CSD	05.31.22
2 60% TO CSD	06.15.22
3 60% TO SWB	07.28.22
4 100% TO CSD	12.14.22
5 100% TO CSD	04.28.23
6 100% TO CSD	06.07.23

DESIGN BY: SS,MS  
DRAWN BY: MS  
REVIEW BY:JPB

© 2023 Watershed Progressive. The design ideas and plans represented by these documents are the property of Watershed Progressive. Use or copy is permitted by contract only. The use or revisions of these ideas or plans is prohibited without the written permission of Watershed Progressive.

WATER REUSE  
AND  
UTILITIES  
ENLARGED PLAN

L6.1A

100% CD

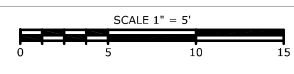

RAINWATER GENERAL NOTES

- A. THE DRAWINGS ARE DIAGRAMMATIC IN NATURE AND ARE CREATED TO REPRESENT THE CONCEPTS AS ASSOCIATED WITH ON-SITE WATER REUSE AND STORM WATER MANAGEMENT / BASIN INSTALLATIONS.
- B. DATUM ASSUMPTION: 3645.00' FROM GOOGLE EARTH AND REFERENCED TO AN ELLIPSOID GPS OBSERVATION
- \* C. ABOVE GROUND RAINWATER TANKS:
  - 1. EACH OUTLET SHALL BE MARKED 'CAUTION NON-POTABLE RAIN WATER, DO NOT DRINK' IN BLACK, CAPITAL LETTERING.
  - 2. RAINWATER PIPING SHALL BE MARKED 'CAUTION NON-POTABLE RAIN WATER, DO NOT DRINK' WITH THE INTERNATIONAL DO NOT DRINK SYMBOL OF A CIRCLED WATER GLASS WITH A DIAGONAL SLASH THROUGH IT
  - 3. TANKS INSTALLED ABOVEGROUND SHALL BE OF AN OPAQUE MATERIAL OR SHIELDED FROM SUNLIGHT
  - 4. RAINWATER TANKS MUST BE INSTALLED WITH A MEANS OF SUFFICIENT VENTING, DRAINING AND CLEANING, INCLUDING ACCESS FOR CLEANING/INSPECTION
  - 5. OVERFLOW SIZING SHALL MATCH OR EXCEED THE AREA OF ALL THE INFLOW PIPING.
  - 6. ALL TANK INLETS, VENTS AND OVERFLOWS SHALL BE PROTECTED WITH A 1/16" OR SMALLER SCREEN
  - 7. TANK MARKING: TANKS SHALL BE PERMANENTLY MARKED WITH 'NON-POTABLE RAINWATER', PERSONNEL TANK ENTRANCES SHALL BE MARKED 'DANGER-CONFINED SPACE'
  - 8. ALL GUTTERS, ROOF DRAINS AND ASSOCIATED PIPING MUST COMPLY WITH RELEVANT CALIFORNIA BUILDING CODES
  - 9. RAINWATER TREATMENT LEVELS SHALL BE TESTED FOR COMPLIANCE WITH TUOLUMNE COUNTY'S RECYCLED WATER QUALITY STANDARDS.
  - 10. ALL EQUIPMENT AND PUMPS USED FOR RAINWATER QUALITY TREATMENT SHALL BE LISTED OR LABELED BY AN ACCREDITED LISTING AGENCY AND HAVE APPROVAL FOR THE INTENDED PURPOSE
  - 11. FREEZE PROTECTION FOR TANKS AND PIPING INCLUDE DRAINING OF THE TANKS AND PROVIDING INSULATION ON THE PIPES AS OUTLINED IN THE EQUIPMENT SCHEDULES.
  - 12. RAINWATER CATCHMENT INFLOW PIPING OR CONVEYANCE PIPING MUST HAVE A 'FIRST FLUSH' INSTALLED TO PREVENT LEAVES, NEEDLES AND SEDIMENT FROM ENTERING THE TANK
  - 13. BACKFLOW PREVENTION DEVICE MUST BE ACCESSIBLE, AND INSTALLED ACCORDING TO THE MANUFACTURER'S GUIDELINES. REFERENCE EQUIPMENT SCHEDULE FOR SIZING DETAILS.
  - 14. RAINWATER SIGNS IN BUILDINGS MUST FOLLOW THE GUIDELINES OF SECTIONS CPC 1602.10.1 AND 1602.10.2 AND OTHER REQUIREMENTS IN THE CALIFORNIA BUILDING CODE
  - 15. INSPECTION: RAINWATER CATCHMENT SYSTEMS SHALL BE INSPECTED AND TESTED IN ACCORDANCE WITH CALIFORNIA PLUMBING CODE SECTIONS 1602.11.1 AND 1602.11.2.
  - 16. INSPECTION INCLUSIONS: RAINWATER CATCHMENT SYSTEMS SHALL BE INSPECTED AND TESTED IN ACCORDANCE WITH CODE PROVISIONS FOR TESTING OF POTABLE WATER SYSTEMS AND STORM DRAINAGE SYSTEMS. STORAGE TANKS SHALL BE FILLED WITH WATER TO THE OVERFLOW LINE FOR A PERIOD OF 24 HOURS AND DURING INSPECTION. SEAMS AND JOINTS SHALL BE EXPOSED DURING INSPECTION AND CHECKED FOR WATERTIGHT-NESS.
- C. TRENCHES WILL BE COVERED DURING END OF WORK DAY AND CROSSING BOARDS LAID EVERY 4 FEET DURING WORK DAY. TRENCHES TO BE FILLED IN AND SET PROPERLY.
- D. ALL ABOVE GROUND PIPES SHALL BE PROTECTED FROM HUMAN/ANIMAL TRAFFIC BEFORE, DURING AND AFTER INSTALLATION.
- E. RAINWATER EQUIPMENT INSTALLED SHALL BE ANS/NSF APPROVED AND BE ACCOMPANIED WITH REFERENCE AND MAINTENANCE INSTRUCTIONS AS LISTED IN MAINTENANCE CONTRACT.
- F. REFER TO FIRST FLUSH CALCULATIONS FOR SIZING.
- G. ALL PIPES SHALL BE INSTALLED A MINIMUM OF 18" FROM TOP OF PIPE TO FINAL GRADE.
- H. ALL NON -POTABLE WATER SUPPLY PIPES FROM RAINWATER TANKS AND PUMPS SHALL BE LABELED PER CALIFORNIA PLUMBING CODE CHAPTER 16.
- I. ALL GRAVITY PIPES SHALL BE INSTALLED AT 1/8" PER 1' SLOPE UNLESS OTHERWISE INDICATED.
- J. ALL BURIED PIPES SHALL HAVE A MINIMUM OF 3" SAND OR PEA GRAVEL AS THEIR BASE.
- K. ALL GRAVITY CONVEYANCE PIPES SHALL ENSURE WATER-TIGHT FITTINGS BY FOLLOWING MANUFACTURER'S INSTRUCTIONS.
- L. CONTRACTOR SHALL VERIFY ALL EXISTING UNDERGROUND UTILITY LOCATIONS PRIOR TO EXCAVATION.

DESIGN CRITERIA

TABLE 1502.4: LOCATION OF GRAY WATER SYSTEM	
MINIMUM HORIZONTAL DISTANCE IN CLEAR REQUIRED FROM	SURFACE AND SUBSOIL IRRIGATION FIELD AND MULCH BASIN
BUILDING STRUCTURES	2
PROPERTY LINE ADJOINING PRIVATE PROPERTY	58
WATER SUPPLY WELLS	100
STREAMS AND LAKES	100
SEWAGE PITS OR CESSPOOLS	5
SEWAGE DISPOSAL FIELDS	46
SEPTIC TANKS	5
ON-SITE DOMESTIC WATER SERVICE LINE	0
PRESSURIZED PUBLIC WATER MAINS	10

PIPE SIZING
<b>PRESSURIZED WATER PIPING:</b> BASIS OF DESIGN: 2016 CALIFORNIA PLUMBING CODE, APPENDIX A 'RECOMMENDED RULES FOR SIZING THE WATER SUPPLY SYSTEM'. PIPING SIZED ON 3 PSI/100 FT. DROP, VELOCITIES NOT TO EXCEED 8 FT./SEC.
<b>ROOF DRAIN/STORM DRAIN PIPING SYSTEM:</b> BASIS OF DESIGN: 2016 CALIFORNIA PLUMBING CODE, CHAPTER 11, 'STORM DRAINAGE'. STORM DRAIN PIPING SIZED AT 1/8"FT. SLOPE UNLESS OTHERWISE NOTED AND A RAINFALL RATE OF 1.5"/HR TRADITIONAL SYSTEM, 3"/HR FOR A COMBINED PRIMARY AND OVERFLOW SYSTEM.
<b>GREYWATER/WASTE/VENT PIPING SYSTEM:</b> BASIS OF DESIGN: 2016 CALIFORNIA PLUMBING CODE, CHAPTER 7, 'SANITARY DRAINAGE'. ALL WASTE PIPING SIZED AT 1/4"FT. SLOPE UNLESS OTHERWISE NOTED.

FIRST FLUSH CALCULATIONS	
ROOF DRAINAGE CHARACTERISTICS	
ROOF CAPTURE AREA	1400 FT <sup>2</sup>
1-INCH STORM VOLUME	117 FT <sup>3</sup>
	873 GAL
FIRST FLUSH DESIGN	
PIPE SIZE	3 IN
PIPE LENGTH	3 FT
WATER VOLUME WITHIN PIPE	1.10 GAL
% VOLUME OF 1-INCH STORM	0.13% GALLONS
TOTAL WATER WEIGHT	9.19 LB

TABLE 1501.5: RECOMMENDED MINIMUM ALTERNATE WATER SOURCE TESTING, INSPECTION, AND MAINTENANCE FREQUENCY	
DESCRIPTION	MINIMUM FREQUENCY
INSPECT AND CLEAN FILTERS SCREENS AND REPLACE WHERE NECESSARY	PER AHJ REQUIREMENTS OR EVERY 3 MONTHS
INSPECT AND VERIFY THAT DISINFECTION, FILTERS AND WATER QUALITY TREATMENT DEVICES AND SYSTEMS ARE OPERATIONAL AND MAINTAINING MIN. WATER QUALITY REQUIREMENTS	PER AHJ AND MANUFACTURER'S INSTRUCTIONS.
INSPECT PUMPS, VALVES, TANKS AND VERIFY OPERATION	
CLEAR DEBRIS FROM AND INSPECT STORAGE TANKS, VERIFY OPERATION	PER AHJ OR AFTER INSTALLATION AND EVERY 12 MONTHS THEREAFTER.
INSPECT CAUTION LABELS AND MARKINGS	
INSPECT AND MAINTAIN MULCH BASINS FOR GREYWATER IRRIGATION SYSTEMS	AS NEEDED TO MAINTAIN MULCH DEPTH AND PREVENT PONDING AND RUNOFF.

TABLE 1101.8 SIZING OF HORIZONTAL RAINWATER PIPING (COMBINED SYSTEM)				
DESIGN RAINFALL RATE = 3 INCHES/HR				
SIZE OF PIPE	DESIGN SLOPE = 1/8-INCH/FOOT		DESIGN SLOPE = 1/4-INCH/FOOT	
	FLOW	MAXIMUM ALLOWABLE HORIZONTAL PROJECTED ROOF AREAS	FLOW	MAXIMUM ALLOWABLE HORIZONTAL PROJECTED ROOF AREAS
INCHES	GPM	SQ. FT.	GPM	SQ. FT.
3	34	1,096	48	1,546
4	78	2,506	110	3,533
6	222	7,133	314	10,066
8	478	15,330	677	21,733
10	860	27,600	1,214	38,950
12	1,384	44,400	1,953	62,600
15	2,473	79,333	3,491	112,000

GREYWATER GENERAL NOTES

- A. THE DRAWINGS ARE DIAGRAMMATIC IN NATURE AND ARE CREATED TO REPRESENT THE CONCEPTS AS ASSOCIATED WITH THE GREYWATER SYSTEM INSTALLATIONS.
- B. GREYWATER SYSTEM INSTALLATION, AS DEFINED IN SECTION 1502.1.2 OF THE CALIFORNIA PLUMBING CODE, CHAPTER 15 AND SHALL COMPLY WITH THE ENTIRETY OF THE CHAPTER. SECTIONS RELEVANT TO THE DESIGN, AS OUTLINED BELOW, SHALL BE VERIFIED FOR COMPLIANCE IN ACCORDANCE WITH THE AUTHORITY HAVING JURISDICTION (AHJ).
  - B.1. 1501.4: ALL SYSTEM COMPONENTS SHALL BE PROPERLY IDENTIFIED PER MANUFACTURER'S INSTRUCTIONS.
  - B.2. 1501.5: ALL SYSTEMS AND COMPONENTS SHALL BE INSPECTED AND MAINTAINED IN ACCORDANCE WITH MANUFACTURER'S RECOMMENDATION. WHERE NO RECOMMENDATIONS EXIST, REFER TO TABLE 1501.5, BELOW.
  - B.3. 1501.6: AN OPERATION MANUAL FOR THE SYSTEM AND COMPONENTS SHALL BE PROVIDED TO INCLUDE THE FOLLOWING TO THE SYSTEM OWNER. THE MANUAL SHALL REMAIN WITH THE BUILDING THROUGHOUT THE LIFE OF THE STRUCTURE.
  - B.4. A DIAGRAM OF THE SYSTEM, INSTRUCTIONS FOR OPERATING, MAINTAINING, TESTING, START UP, SHUTDOWN AND DEACTIVATING THE SYSTEM.
  - B.5. A METHOD OF CONTACT FOR THE MANUFACTURER.
  - B.6. 1501.14: ALL GREYWATER PIPING SHALL BE SIZED IN ACCORDANCE WITH CALIFORNIA PLUMBING CODE FOR SANITARY DRAINAGE AND VENTING.
  - B.7. 1502.1: HEALTH AND SAFETY CODE SECTION 1891.7 SHALL BE FOLLOWED UNLESS AN OTHERWISE MORE RESTRICTIVE STANDARD IS DETERMINED BY AHJ.
  - B.8. THREE-WAY DIVERTER VALVE SHALL BE PROVIDED WITH CLEAR LABEL INDICATING DIRECTION OF FLOW. DIVERTER VALVE SHALL BE READILY ACCESSIBLE.
  - B.9. 1502.2: GREYWATER DRAINS SHALL BE PROVIDED WITH A BACKWATER VALVE AT THE POINT OF CONNECTION TO THE BUILDING SEWER SYSTEM AND BE ACCESSIBLE FOR INSPECTION AND MAINTENANCE.
  - B.10. 1502.4: THE LOCATION OF THE GREYWATER SYSTEM SHALL FOLLOW TABLE 1503.4 AS OUTLINED.
  - B.11. 1502.8: GREYWATER SYSTEMS SHALL BE DESIGNED TO DISTRIBUTE THE TOTAL AMOUNT OF GREYWATER ON A DAILY BASIS PER SECTION 1502.8.1 FOR RESIDENTIAL PROJECTS AND 1502.8.2 FOR COMMERCIAL PROJECTS.
  - B.12. 1503.7: ALL MECHANICAL EQUIPMENT, INCLUDING CONTROL VALVES, APPURTENANT TO RECYCLED WATER SUPPLY SYSTEMS SHALL BE PAINTED PURPLE OR COMPOSED OF PURPLE MATERIAL MATCHING PANTONE COLOR NO. 512, 522C OR EQUIVALENT. RECYCLED WATER SUPPLY SYSTEMS SHALL BE IDENTIFIED AND PERMANENTLY MARKED WITH CLEARLY VISIBLE BLACK UPPERCASE LETTERING ON PURPLE BACKGROUND. FOR EITHER MATERIAL, THE TAPE OR PIPE SHALL BE INSTALLED SO THE WORDING IS CLEARLY VISIBLE AND SHALL BE FIELD OR FACTORY MARKED AS FOLLOWS, EVERY 5-FEET: "CAUTION: NON-POTABLE RECYCLED WATER, DO NOT DRINK".
- C. ALL VALVES AND DEVICES SHALL BE ANS/NSF APPROVED, ACCOMPANIED WITH REFERENCE AND MAINTENANCE INSTRUCTIONS AS LISTED IN THE PROVIDED MAINTENANCE CONTRACT.
- D. ALL IRRIGATION POINTS TO BE 2 INCHES BELOW THE SURFACE IN MULCH BASINS.
- E. GREYWATER SYSTEM MUST BE EQUIPPED WITH ACCESSIBLE THREE WAY DIVERTER VALVE WITH SIGN THAT INDICATES OPERATION, SO DISCHARGE WATER CAN BE DIVERTED TO SEPTIC/SEWER DURING RAIN EVENTS OR IF SOIL REACHES A HIGH LEVEL OF SATURATION.
- F. PRODUCTS WITH BLEACH, SALT, ALCOHOL OR OTHER INDUSTRIAL CHEMICALS ARE NOT RECOMMENDED FOR USE IN THESE GREYWATER SYSTEMS.
- G. GREYWATER PIPES SHALL SLOPE DOWNWARD AT 2 DEGREES OR 1/4" PER FOOT.
- H. ALL GREYWATER CONVEYANCE LINES SHALL BE MARKED "NON POTABLE, DO NOT DRINK".
- I. ALL EQUIPMENT SHALL BE ANS/NSF APPROVED AND BE ACCOMPANIED WITH REFERENCE AND MAINTENANCE INSTRUCTIONS PER MAINTENANCE AND MONITORING PLAN. PROVIDED TO OWNER.
- J. ALL SYSTEM P.O.Cs TO BE VERIFIED AND FINALIZED IN FIELD.
- K. ALL EXISTING TANKS, PIPING, AND ELECTRICAL WORK SHALL BE AVOIDED AND PROTECTED WHEN NECESSARY THROUGHOUT CONSTRUCTION.

WATER REUSE EQUIPMENT SCHEDULES

RAINWATER TANK SCHEDULE					
TAG NUMBER	LOCATION	VOLUME (GROSS GAL.)	DIMENSIONS (DIA. X H)	MAKE, MODEL	QTY
TANK-1	MEADOWS	5,000	10'-9" x 8'	BUSHMAN POLY 5050, CWTX5-132 OR APPROVED EQUAL	6
TANK-2	PAVILION	5,000	9'-11" x 7'-6"	BH CLASSIC CORRUGATED, BH09X07 OR APPROVED EQUAL	1
TANK-3	BOARDWALK	1,152	9'-11" x 7'-6"	AQUASCAPE MODULAR SYSTEM: LARGE CRATES OR APPROVED EQUAL	36

PUMP SCHEDULE							
TAG NUMBER	DESCRIPTION	LOCATION	PERFORMANCE			MAKE, MODEL	QTY
			FLOW (nominal/max)	TOTAL DEVELOPED HEAD	POWER		
			(GPM)	(FT)	(HP/W TOTAL)		
PUMP-1	SUBMERSIBLE RW PUMP	TANK-1	13 / 25	147	1.43 HP	GRUNDFOS, SBA 3-45-AW OR APPROVED EQUAL	1
PUMP-2	AQUASCAPE 9PL	BOARDWALK	24 / 50	35	1000 W	AQUASCAPE 9PL 7,000GPH PUMP OR APPROVED EQUAL	1
PUMP-3	OASE POND PUMP	BOARDWALK	31	9.5	70 W	OASE AQUAMAX ECO CLASSIC 1900 PUMP OR APPROVED EQUAL	1

PIPE SCHEDULE				
SERVICE	PIPE TAG	SIZE	MATERIAL	INSULATION
* NON-POTABLE WATER SUPPLY	NPW	2" OR SMALLER	SCHEDULE 40 / 80 PVC; ASTM D1785	PROVIDE INSULATION ON ABOVE GROUND PIPES. 1-1/2" FIBERGLASS, ALL-PURPOSE JACKET. COVER WITH METAL PIPE JACKET WHERE EXPOSED TO WEATHER.  FIBERGLASS SHALL BE SPLIT SECTIONAL OR SNAP ON TYPE WITH 0.23 PER INCH MAX. THERMAL CONDUCTIVITY (K-FACTOR) AT 75F MEAN TEMP. PROVIDE VAPOR BARRIER JACKET WITH PRESSURE SENSITIVE CLOSURE SYSTEM. JOHNS MANSVILLE MICROLOK HP OR APPROVED EQUAL
* DOMESTIC WATER	CW			METAL PIPE JACKET SHALL BE 0.016-INCH THICK ALUMINUM WITH FORMED FITTING COVERS, ALUMINUM SNAP STRAPS AND SEALANT
* RAINWATER/ RW OVERFLOW CONVEYANCE	RW OVC	6" OR SMALLER	SCHEDULE 40 PVC; ASTM D1785.	FOR FREEZE PROTECTION, SYSTEM SHALL BE DRAINED.
* SANITARY WASTE & VENT	SS V	6" OR SMALLER	CAST IRON SOIL PIPE, SERVICE WEIGHT (NO HUB); NO HUB PIPE AND FITTINGS ASTM A74, CISPI, WITH 28 GAUGE 304 STAINLESS STEEL CLAMP AND CORRUGATED SHIELD ASSEMBLIES HAVING NEOPRENE GASKETS ASTM C564, CISPI 310-90, SCHEDULE 40 PVC OR ABS DIVV; ASTM D2665-85a, ASTM D3311-82.	N/A

EQUIPMENT SCHEDULE			
TAG NUMBER	LOCATION	DESCRIPTION	QTY
* GT-1	GUTTER	RECTANGULAR STEEL GUTTER. REFER TO PLANS FOR LENGTH, 5-INCH DIA.	REFER TO PLANS
CO-1	GRAVITY PIPING SYSTEMS	2-WAY CLEAN OUT COMBO TEE WITH THREAD ADAPTER AND PLUG SIMILAR TO: 2", ABS, CANPLAS	13
DS-1	PAVILION	DOWNSPOUT FILTER: RAINHARVEST LEAF EATER ADVANCED DOWNSPOUT FILTER OR APPROVED EQUAL	4
		DOWNSPOUT PIPE FIRST FLUSH ASSEMBLY: RAIN HARVESTING PTY 3 WITH ADVANCED RELIEF VALVE OR APPROVED EQUAL	4
MV-1	TANK-1	MAKE UP WATER VALVE: 3/4" RAINAID OR APPROVED EQUAL	2
MV-2	BOARDWALK	MAKE UP WATER VALVE: 1" HUDSON ON-DEMAND FILL VALVE & MOUNTING KIT OR APPROVED EQUAL	1
* BF-1	TANK-1	BACKFLOW PREVENTER: 1" ZURN 375-XL REDUCED PRESSURE BACKFLOW ASSEMBLY OR APPROVED EQUAL	1
* E-1	TANK-1	ENCLOSURE: BACKFLOW ARMOR EKONO303013 ENCLOSURE OR APPROVED EQUAL	1
B-1	FLUME	BASIN: AQUASCAPE AQUABASIN-45 / 98-GALLON CAPACITY OR APPROVED EQUAL	1
UV-1	BOARDWALK	ULTRAVIOLET TREATMENT: OASE BIO-SMART 5000 POND FILTER W/ VITRONIC 18 UV CLARIFIER OR APPROVED EQUAL	1

APPLICABLE CODES AND REGULATIONS

- 1. CALIFORNIA PLUMBING CODE
- 2. CALIFORNIA BUILDING CODE
- 3. CALIFORNIA ELECTRICAL CODE



Twain Heart Meadows Park  
22945 Meadow Drive, Twain Harte, CA, 95383

DATE: PROJECT NO.	
REVISION	DATE
1 60% DRAFT TO CSD	05.31.22
2 80% TO CSD	06.15.22
3 60% TO SWB	07.28.22
4 100% TO CSD	12.14.22
5 100% TO CSD	04.28.23
6 100% TO CSD	06.07.23
DESIGN BY: SS,MS	
DRAWN BY: MS	
REVIEW BY: JP8	

© 2023 Watershed Progressive. The design ideas and plans represented by these documents are the property of Watershed Progressive. Use or copy is permitted by contract only. The use or revisions of these ideas or plans is prohibited without the written permission of Watershed Progressive.

WATER REUSE AND UTILITIES SCHEDULE

L6.2



WATERSHED PROGRESSIVE  
 WWW.WATERSHEDPROGRESSIVE.COM  
 209.752.0018  
 CENTRAL SIERRA OFFICE  
 8553 MAIN STREET  
 GROVELAND, CALIFORNIA 95321  
 OJAI OFFICE  
 206 N. SIGNAL ST., SUITE 5  
 OJAI, CALIFORNIA 93023

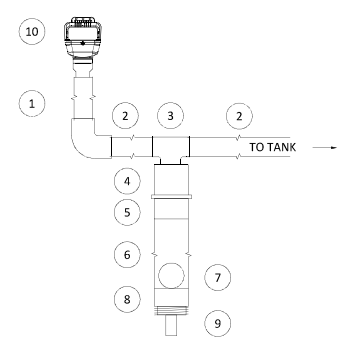

- DETAIL NOTES:**
- 1) PVC LEADER PIPE
  - 2) PVC PIPE
  - 3) PVC TEE
  - 4) BUSHING
  - 5) PVC COUPLER
  - 6) PVC W/ STOPPER BALL DIAMETER >2", <-2.75"
  - 7) PVC FTA
  - 8) BUSHING MPT X FPT
  - 9) RAINAID ADVANCED RELIEF VALVE
  - 10) LEAF GUARD (AT DOWNSPOUT LOCATION)

- GENERAL NOTES:**
- A. MATERIALS FASTENED WITH TWO WALL STRAPS.
  - B. ASSEMBLY IS OF TYP. FIRST FLUSH UNIT.
  - C. ALTERNATE: USE APPROVED MONOLITHIC ASSEMBLY.
  - D. ALTERNATE: USE APPROVED MOZZIE STOPPA OVERFLOW SCREEN.

**1 FIRST FLUSH ASSEMBLY DETAIL (TYP.)**  
(N.T.S)

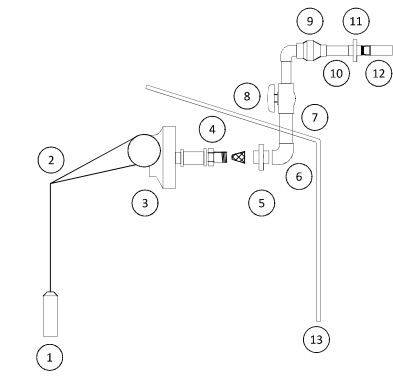

- DETAIL NOTES:**
- 1) ACTIVATOR FLOAT - ADJUST LINE LENGTH FOR DESIRED FILL HEIGHT
  - 2) SWING ARM ACTIVATOR
  - 3) MAKE-UP WATER FILL OPENING
  - 4) SCREEN FILTER
  - 5) 3/4" PVC SCH. 40 UNION FPT
  - 6) 3/4" PVC SCH. 40 90 ELBOW MPT X FPS
  - 7) 3/4" PVC SCH. 40 PIPE
  - 8) 3/4" PVC SCH. 40 BALL VALVE FPS  
INSTALL W/ BALL VALVE HOUSING TOUCHING CISTERN HANDLE TO FACE DOWNHILL SLOPE OF CISTERN ROOF.
  - 9) 3/4" PVC SCH. 40 SPRING CHECK VALVE FPT 3/4"
  - 10) 3/4" X 2" LONG PVC SCH. 80 NIPPLE MPT
  - 11) 3/4" PVC SCH. 40 UNION FPT
  - 12) 3/4" PVC SCH. 40 MALE THREAD ADAPTER
  - 13) CISTERN WALL

**3 RAINWATER MUNICIPAL MAKEUP WATER ASSEMBLY**  
(N.T.S)

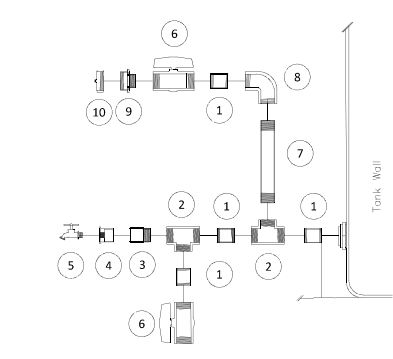

- DETAIL NOTES:**
- 1) 2", 2.5" LONG PVC THREADED NIPPLE
  - 2) 2" PVC SCH. 40 TEE, FPT X FPT X FPT
  - 3) 2" PVC SCH. 40 MALE THREAD ADAPTER
  - 4) 2" -> 3/4" ADAPTER BUSHING, 2" MPS X 3/4" FPT
  - 5) 1/4" BRASS HOSE BIB, MPT
  - 6) 2" PVC SCH. 40 BALL VALVE FPT X FPT
  - 7) 2", 12" PVC SCH. 40 THREADED NIPPLE
  - 8) 2" PVC SCH. 40 90 ELBOW, FPT X FPT
  - 9) 2.5" NHT -> 2" MPT BRASS THREADED ADAPTER
  - 10) 2.5" BRASS FIRE CAP, FPT

- GENERAL NOTES:**
- A. SUPPORTING BLOCK SHALL BE PLACED BELOW OUTFLOW TO PROVIDE PIPE SUPPORT.

**4 RAINWATER CISTERN MANIFOLD**  
(N.T.S)

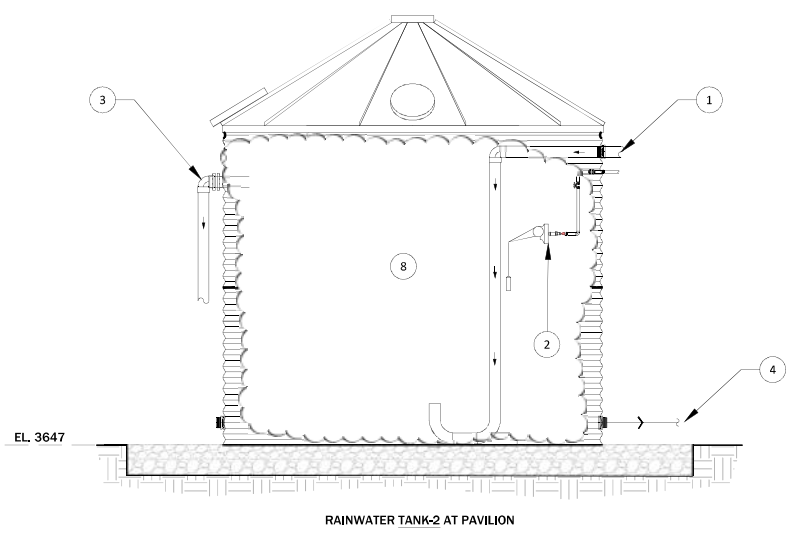

- DETAIL NOTES:**
1. 3" RAINWATER FROM PAVILION
  2. MV-1: RAINAID MAKEUP WATER VALVE
  3. 3" RAINWATER OVERFLOW TO CREEK
  4. 1" PVC RAINWATER (RW) TO UNDERGROUND CISTERN'S ON-DEMAND VALVE MV-2
  5. MV-2: 1" HUDSON ON-DEMAND WATER FILL VALVE
  6. PUMP-2 & PUMP-3: PUMP(S) AND HOUSING
  7. 3/4" PVC PUMPED RAINWATER (NPW) TO FLUME WATER FEATURE
  - \* 8. TANK-2: CORRUGATED STEEL RAINWATER TANK, PORTS AND EQUIPMENT INSTALLED BY WP. ALL WORK RELATED TO TANK-2 SHALL BE COORDINATED WITH TANK MANUFACTURER, (REF. EQUIPMENT SCHEDULE)
  9. TANK-3: AQUASCAPE MODULAR UNDERGROUND TANK (REF. EQUIPMENT SCHEDULE)

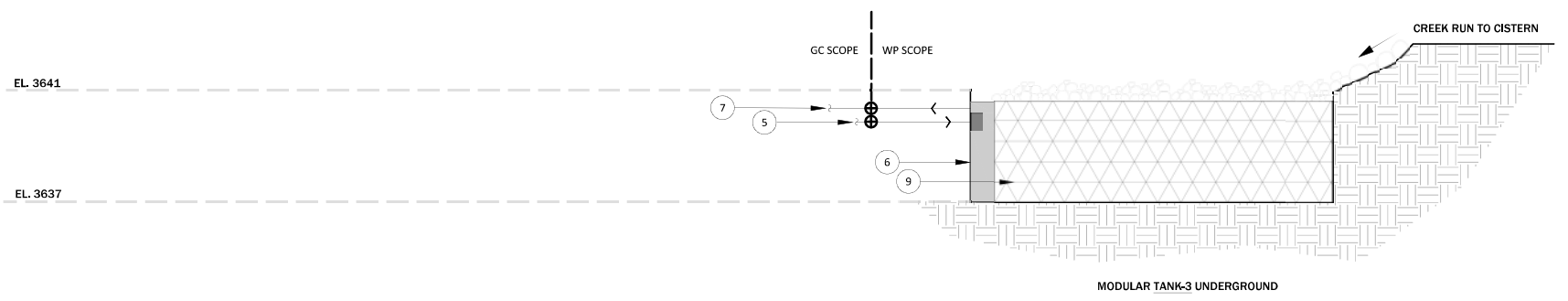

**2 RAINWATER TANK-2 MAKEUP WATER AND FEED LINE TO WATER DISCOVERY LAB UNDERGROUND TANK-3 - ELEVATION VIEW**  
(N.T.S)

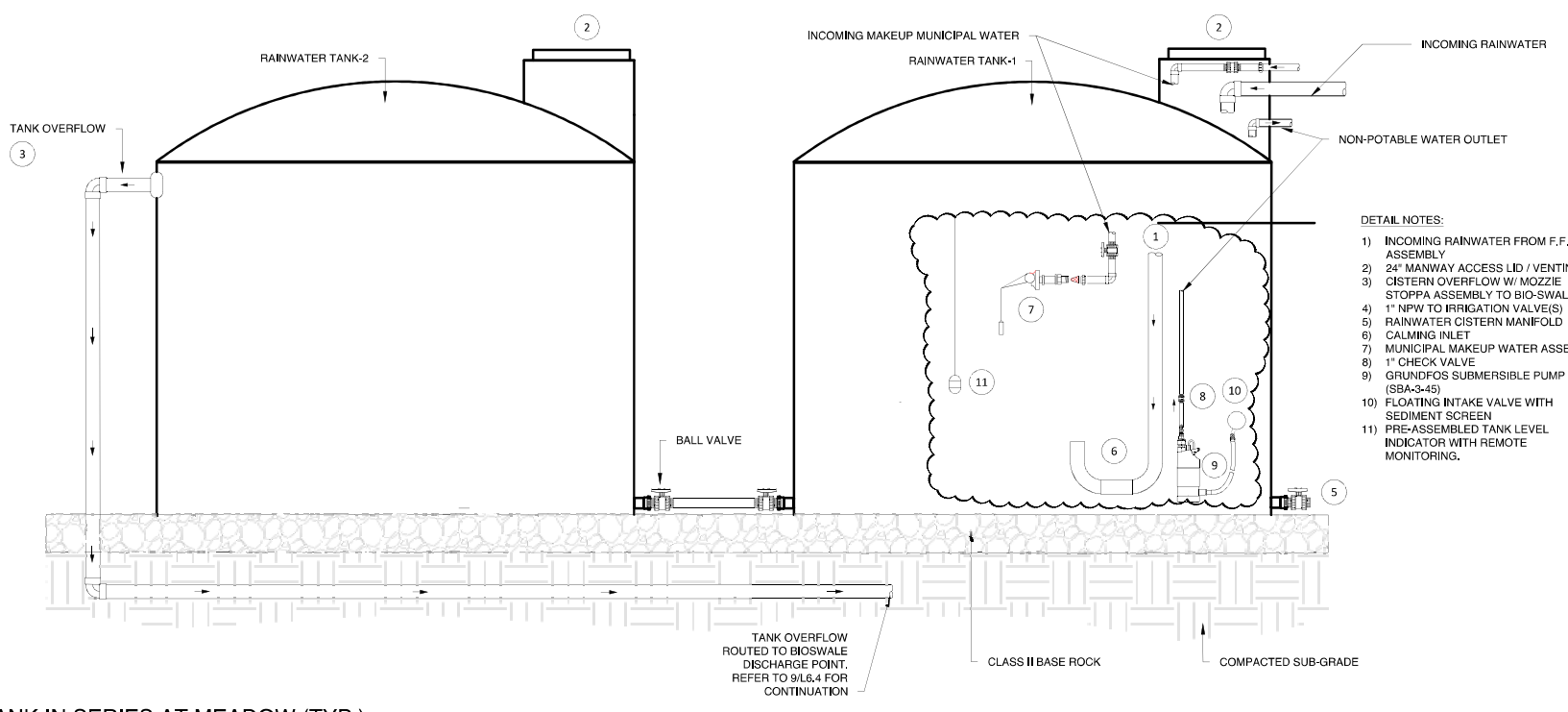

- DETAIL NOTES:**
- 1) INCOMING RAINWATER FROM F.F. ASSEMBLY
  - 2) 24" MANWAY ACCESS LID / VENTING
  - 3) CISTERN OVERFLOW W/ MOZZIE STOPPA ASSEMBLY TO BIO-SWALE.
  - 4) 1" NPW TO IRRIGATION VALVE(S)
  - 5) RAINWATER CISTERN MANIFOLD
  - 6) CALMING INLET
  - 7) MUNICIPAL MAKEUP WATER ASSEMBLY
  - 8) 1" CHECK VALVE
  - 9) GRUNDFOS SUBMERSIBLE PUMP (SBA-3-45)
  - 10) FLOATING INTAKE VALVE WITH SEDIMENT SCREEN
  - 11) PRE-ASSEMBLED TANK LEVEL INDICATOR WITH REMOTE MONITORING.

**5 POLY TANK IN SERIES AT MEADOW (TYP.)**  
(N.T.S)

Twain Heart Meadows Park  
 22945 Meadow Drive, Twain Harte, CA, 95383

DATE: PROJECT NO.

REVISION	DATE
1 60% DRAFT TO CSD	05.31.22
2 60% TO CSD	06.15.22
3 60% TO SWB	07.28.22
4 100% TO CSD	12.14.22
5 100% TO CSD	04.28.23
6 100% TO CSD	06.07.23

DESIGN BY: SS, MS  
 DRAWN BY: MS  
 REVIEW BY: JPB

© 2023 Watershed Progressive. The design ideas and plans represented by these documents are the property of Watershed Progressive. Use or copy is permitted by contract only. The use or revisions of these ideas or plans is prohibited without the written permission of Watershed Progressive.

**WATER REUSE AND UTILITIES DETAILS**

**L6.3**

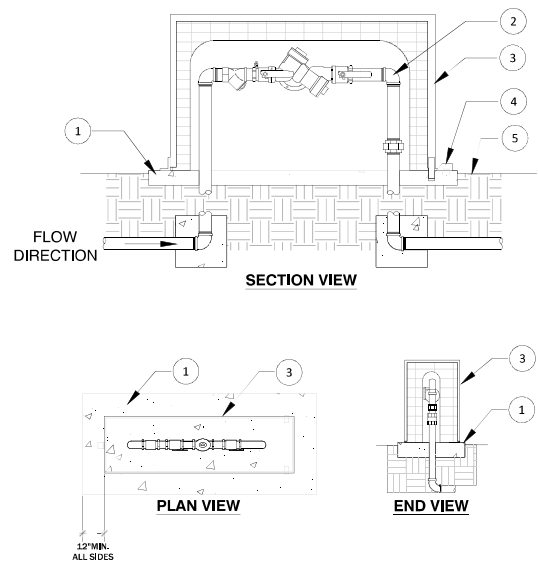

- DETAIL NOTES:**
- 1) 4" THICK CONCRETE FOOTING 1" ABOVE FINISHED GRADE
  - 2) BACK FLOW PREVENTION DEVICE
  - 3) BACK FLOW CAGE
  - 4) LOCK BOX
  - 5) FINISHED GRADE
- GENERAL NOTES:**
- A. INSTALL BACK FLOW ENCLOSURE PER MANUFACTURERS SPECIFICATIONS AND RECOMMENDATIONS.
  - B. SEE BACK FLOW PREVENTION DEVICE DETAIL FOR REFERENCE.
  - C. LOCK BOX SHALL BE LOCATED ABOVE CONCRETE FOOTING.
  - D. LOCK TO BE PROVIDED BY CONTRACTOR OR AS APPROVED BY OWNER.

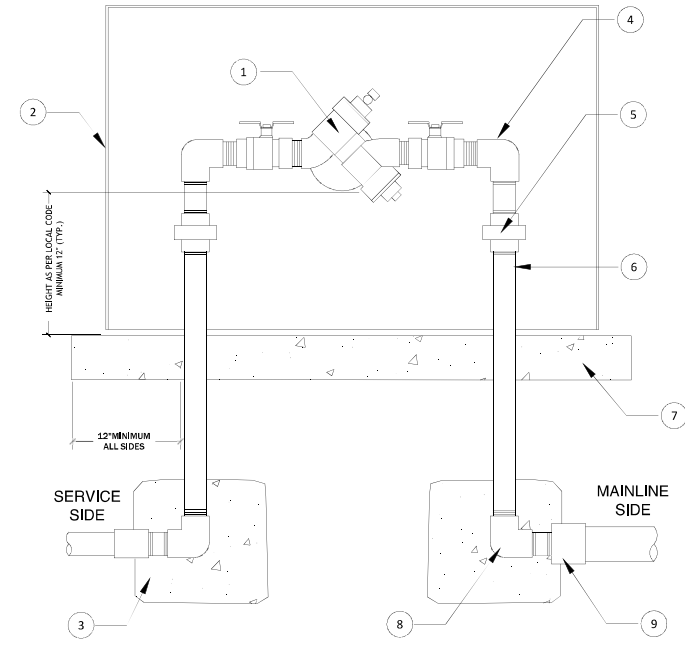

- DETAIL NOTES:**
- 1) REDUCED PRESSURE BACK FLOW DEVICE AS SPECIFIED
  - 2) BACK FLOW ENCLOSURE AS SPECIFIED
  - 3) CONCRETE THRUST BLOCKS
  - 4) GALVANIZED NIPPLES AND ELL AS REQUIRED
  - 5) GALVANIZED UNIONS AT EACH SIDE
  - 6) GALVANIZED RISERS
  - 7) 4" THICK MINIMUM CONCRETE PAD
  - 8) GALVANIZED ELL AND NIPPLE, TYPICAL
  - 9) PVC COUPLER OR REDUCER AS REQUIRED, TYPICAL
- GENERAL NOTES:**
- A. PROVIDE REDUCED PRESSURE BACK FLOW PREVENTER OF ANY EXISTING WELL WATER CONNECTION TO NEW OUTLET / FIXTURE.
  - B. IN ACCORDANCE WITH CALIFORNIA PLUMBING CODE 2022 CHAPTER 15 AND 16
  - C. UNIONS TO BE PLACED AS NEEDED (EASE OF MAINTENANCE + REPLACEMENT)
  - D. REDUCED PRESSURE BACK FLOW PREVENTER TO BE TESTED BY QUALIFIED TECHNICIAN.

- DETAIL NOTES:**
- 1) FLOATING BALL
  - 2) SUCTION STRAINER (1MM MESH)
  - 3) FLEXIBLE TUBING
  - 4) FLOAT SWITCH
  - 5) SUBMERSIBLE PUMP
  - 6) BARBED FITTING + HOSE CLAMP
  - 7) SUPPLY LINE
  - 8) NON-RETURN CHECK VALVE
  - 9) UNION
  - 10) PUMP LINE OUT
  - 11) PUMP POWER LINE

- GENERAL NOTES:**
- A. TYPICAL SUBMERSIBLE PUMP SETUP COMPONENT FLOW.
  - B. THE FLOAT SWITCH OFFERS STOP AT LOW WATER LEVEL, ENSURING THAT SURFACE FRAGMENTS DO NOT ENTER THE STRAINER.
  - C. NON-RETURN CHECK VALVE TO BE INSTALLED IN-LINE TO ENSURE PUMP REMAINS PRIMED AND OPERATING EFFICIENTLY.
  - D. UNIONS TO BE PLACED AS NEEDED (EASE OF MAINTENANCE + REPLACEMENT)
  - E. ENSURE SUBMERSIBLE PUMP IS PLACED SECURELY IN A VERTICAL POSITION INSIDE TANK.
  - F. ELECTRICAL POC FOR PUMP TO BE ADDED BY ELECTRICAL CONTRACTOR

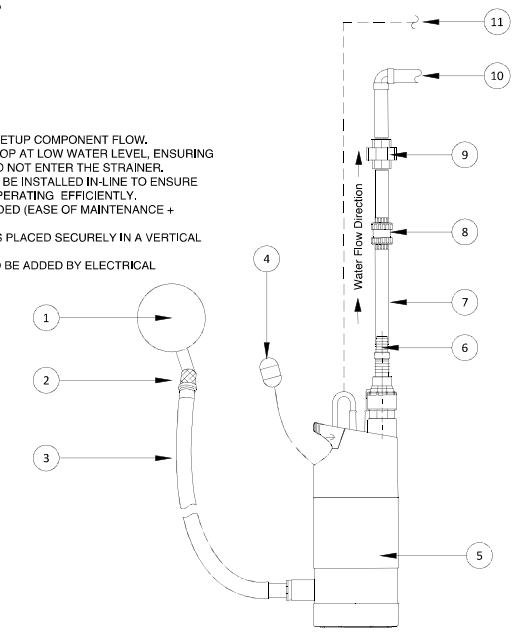

6 \* BACKFLOW PREVENTER ENCLOSURE (N.T.S)

7 \* REDUCED PRESSURE BACKFLOW DEVICE (N.T.S)

8 \* SUBMERSIBLE PUMP DETAIL (TYP) (N.T.S)

- GENERAL NOTES:**
- A. BIO-SWALE ALIGNMENT MAY BE STRAIGHT OR MEANDERING, DEPENDING ON AVAILABLE SPACE.
  - B. TREES AND SHRUBS SHOULD BE LOCATED AN APPROPRIATE DISTANCE FROM THE SWALE BASED ON SPECIES' TOLERANCE OF SATURATED SOIL CONDITIONS.
  - C. USE OF GRAVEL / RIVER ROCK / MULCH AND SWALE DEPTHS TO BE VERIFIED ON-SITE.
  - D. SPOT AMEND PLANTS WITH A MIX OF COMPOST AND NATIVE SOIL. MAXIMUM 3:1 SLOPE
- DETAIL NOTES:**
- 1) (E) GRADE - ADJACENT SURFACES MAY VARY
  - 2) UN-COMPACTED SUB GRADE
  - 3) NATIVE SWALE BASIN PLANTS - REFERENCE PLANTING PLAN
  - 4) GRAVEL / RIVER ROCK - 3-4" DEPTH (MAXIMUM OF 6')
  - 5) MULCH, 3-4" DEPTH (MAXIMUM OF 6')
  - 6) FILL LINE
  - 7) RAINWATER CISTERN SIDE WALL
  - 8) RAINWATER OVERFLOW CONVEYANCE PIPE
  - 9) RAINWATER OVERFLOW INTO BIO-SWALE. PROVIDE WITH SCREENED OUTLET.

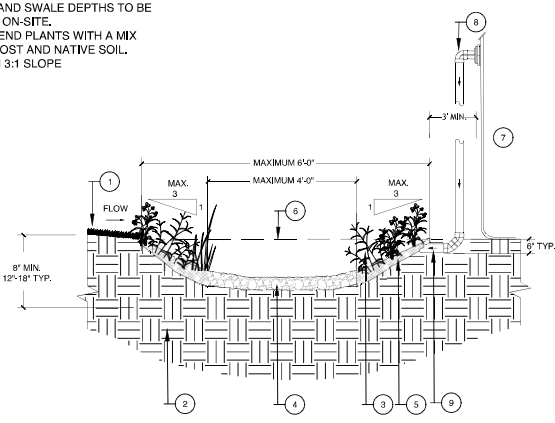

9 BIO-SWALE + RAINWATER TANK DISCHARGE (TYP.) (N.T.S)

- GENERAL NOTES:**
- A. ENSURE SUB-GRADE IS WELL COMPACTED AND LEVEL.
  - B. ENSURE CLASS II BASE ROCK - COMPACTED 95%
  - C. REFERENCE SITE PLAN FOR PAD DIMENSIONS & LAYOUT.
  - D. RAINWATER CISTERN PAD LAYOUT AND DIMENSIONS TO BE STAKED OUT AND VERIFIED PRIOR TO GRAVEL BASE FILL & COMPACTION.
  - E. REFERENCE TANK MANUFACTURER PAD SPECIFICATIONS AS NEEDED.

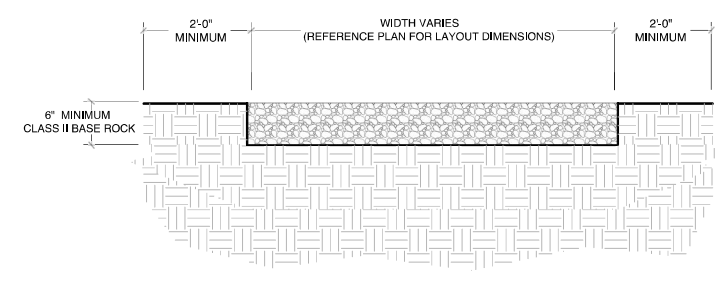

10 \* RAINWATER CISTERN PAD DETAIL (TANK-1 AND TANK-2) (N.T.S)

- DETAIL NOTES:**
- 1) NON-PRESSURIZED LINE (RW, OVERFLOW, SS)
  - 2) PRESSURIZED LINE (W, CW, NPW, PUMPED RW)
  - 3) DETECTABLE LOCATOR TAPE
  - 4) DIRECT BURIAL LOW VOLTAGE CONTROL WIRES
  - 5) PIPE SLEEVE - PVC CLASS 200 SDR 21
  - 6) FINISHED GRADE
  - 7) PAVEMENT
  - 8) UNDISTURBED SUB-GRADE
  - 9) SAND BEDDING - MINIMUM 3"

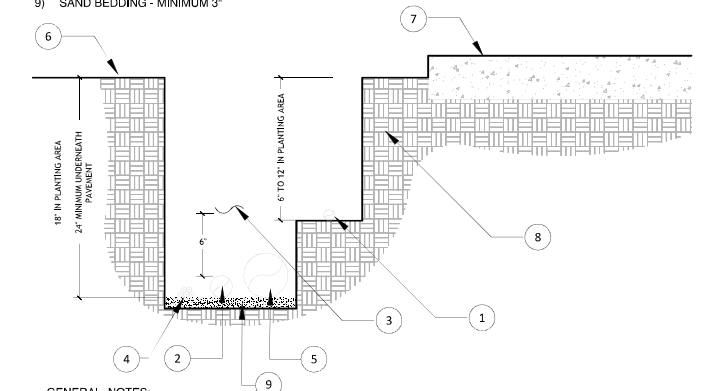

- GENERAL NOTES:**
- A. SEE PIPE SCHEDULE FOR SIZES AND TYPES.
  - B. DIRECT BURIAL CONTROL WIRES SHALL BE INSTALLED IN SCH. 40 PVC ELECTRICAL CONDUIT IF REQUIRED.
  - C. 2-WIRE IRRIGATION WIRE SHALL BE INSTALLED IN SCH. 40 PVC ELECTRICAL CONDUIT.
  - D. DETECTABLE LOCATOR TAPE SHALL BE LOCATED SIX INCHES (6") ABOVE THE ENTIRE MAINLINE RUN.
  - E. FOR UTILITY TRENCHES, COMPACT THE INITIAL BACKFILL USING NATIVE SOIL, TO A RELATIVE COMPACTION OF 95%
  - F. FOR UNPAVED AREAS, COMPACT NATIVE SOIL MATERIAL TO A RELATIVE COMPACTION OF 85%

11 TRENCHING (TYP) (N.T.S)

Twain Heart Meadows Park  
 22945 Meadow Drive, Twain Harte, CA, 95383

DATE: PROJECT NO.

REVISION	DATE
1 60% DRAFT TO CSD	05.31.22
2 60% TO CSD	06.15.22
3 60% TO SWB	07.28.22
4 100% TO CSD	12.14.22
5 100% TO CSD	04.28.23
6 100% TO CSD	06.07.23

DESIGN BY: SS,MS  
 DRAWN BY: MS  
 REVIEW BY: JPB

© 2023 Watershed Progressive. The design ideas and plans represented by these documents are the property of Watershed Progressive. Use or copy is permitted by contract only. The use or revisions of these ideas or plans is prohibited without the written permission of Watershed Progressive.

WATER REUSE AND UTILITIES DETAILS

L6.4

DETAIL NOTES:

- 1) GREYWATER CONVEYANCE LINE TO MULCH BASIN
- 2) MULCH BASIN (3/4" WOOD CHIPS)
- 3) VALVE BOX
- 4) VALVE BOX LID (REMOVE FOR INSPECTION OR MAINTENANCE)

GENERAL NOTES:

- A. ENSURE ROOT CROWN IS ABOVE SOIL LEVEL AND NO MULCH AROUND CROWN TO KEEP IT WELL VENTILATED AND DRAINED, REDUCING DISEASE.
- B. ENSURE MULCH BASINS ARE FLAT FOR EVEN WATER INFILTRATION.
- C. PLANTING HOLE TO BE EXCAVATED AND BACKFILLED WITH PLAIN NATIVE SOIL FOR NATIVE TREES.
- D. MULCH: CLIPPINGS, WOOD CHIPS, LEAVES OR AS SPECIFIED IN PLANTING PLAN.
- E. GREYWATER CONVEYANCE LINE AT A MINIMUM 2% SLOPE.
- F. REFERENCE GREYWATER SYSTEM NOTES FOR MULCH BASIN SPECIFICATIONS.
- G. ENSURE ALL GREYWATER EQUIPMENT IS LABELED "NON-POTABLE WATER"
- H. ENSURE ALL LOCAL CITY AND COUNTY REGULATIONS ARE MET AND PER LATEST CPC REGULATIONS.

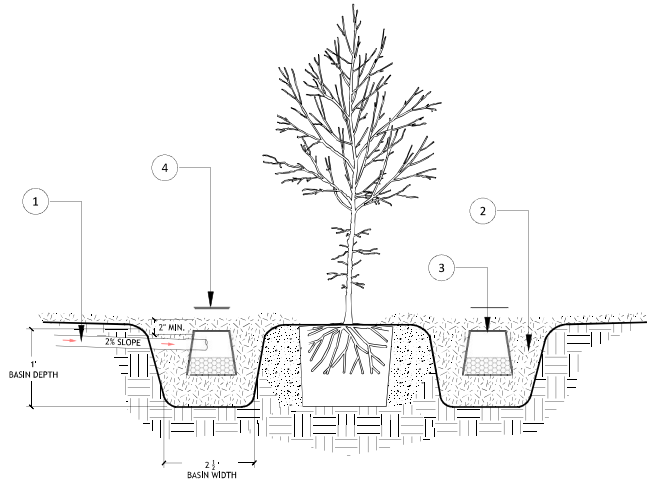

12 GREYWATER MULCH BASIN (TYP.)  
(N.T.S)

DETAIL NOTES:

- 1) 3-WAY DIVERTER VALVE (MUST BE ACCESSIBLE)
- 2) BACKWATER VALVE (MUST BE ACCESSIBLE)
- 3) CLEANOUT

GENERAL NOTES:

- A. LAV - RESTROOM LAVATORY (SINK)
- B. F.U. - FIXTURE UNIT
- C. V.T.R. - VENT THROUGH ROOF
- D. 3-WAY DIVERTER VALVE AND BACKWATER VALVE FOR GREYWATER SYSTEM MUST BE ACCESSIBLE.
- E. ALL GREYWATER PIPES MUST SLOPE 1/4" PER FOOT.

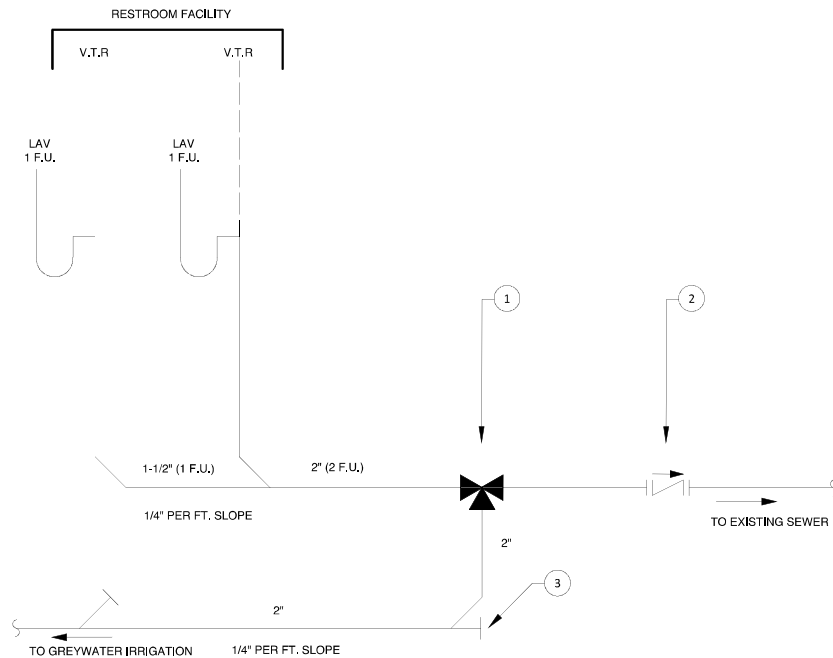

14 GREYWATER RISER DIAGRAM (TYP.)  
(N.T.S)



GENERAL NOTES:

- A. RAINWATER TANKS SHALL HAVE APPROPRIATE SIGNAGE NOTING "NON-POTABLE WATER" AND "DANGER CONFINED SPACE" ALL IN ACCORDANCE WITH CALIFORNIA PLUMBING CODE CHAPTER 16.
- B. SIGNAGE SHALL BE UV, CHEMICAL, ABRASION AND FADE RESISTANT.

13 NON-POTABLE SIGNAGE: SYSTEM LOCATION AND TANKS (TYP.)  
(N.T.S)



GENERAL NOTES:

- A. RAINWATER CONVEYANCE LINES SHALL HAVE APPROPRIATE SIGNAGE NOTING "NON-POTABLE WATER" ALL IN ACCORDANCE WITH CALIFORNIA PLUMBING CODE CHAPTER 16.
- B. ADHESIVE PIPE MARKERS SHALL BE UV, CHEMICAL, ABRASION AND FADE RESISTANT.

15 NON-POTABLE SIGNAGE - PIPE MARKER (TYP.)  
(N.T.S)

Twain Heart Meadows Park  
 22945 Meadow Drive, Twain Harte, CA, 95383

DATE:  
PROJECT NO.

REVISION	DATE
1 60% DRAFT TO CSD	05.31.22
2 60% TO CSD	06.15.22
3 60% TO SWB	07.28.22
4 100% TO CSD	12.14.22
5 100% TO CSD	04.28.23
6 100% TO CSD	06.07.23

DESIGN BY: SS,MS  
 DRAWN BY: MS  
 REVIEW BY: JPB

© 2023 Watershed Progressive. The design ideas and plans represented by these documents are the property of Watershed Progressive. Use or copy is permitted by contract only. The use or revisions of these ideas or plans is prohibited without the written permission of Watershed Progressive.

WATER REUSE  
 AND  
 UTILITIES  
 DETAILS

L6.5



GENERAL NOTES:

- A. FLUME TO BE STAINED WITH WOOD PROTECTANT AND THEN WITH A 2-PART CLEAR COAT EPOXY FOR LINING. ALL SAMPLES OF WOOD PROTECTANT AND CLEAR COAT EPOXY TO BE PROVIDED BY WATERSHED PROGRESSIVE 2-WEEKS BEFORE BUILD.
- B. RE-APPLICATION OF COATING BETWEEN 5-10 YEARS OR AS NEEDED.
- C. USE OF METAL OR WOOD DOWELS WILL BE DETERMINED IN THE FIELD BY WATERSHED PROGRESSIVE.

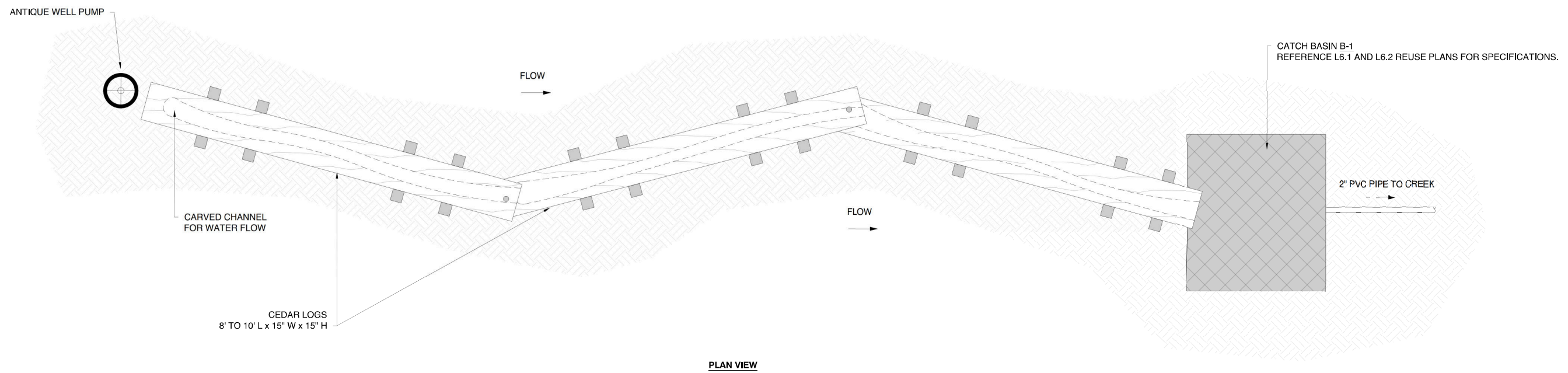
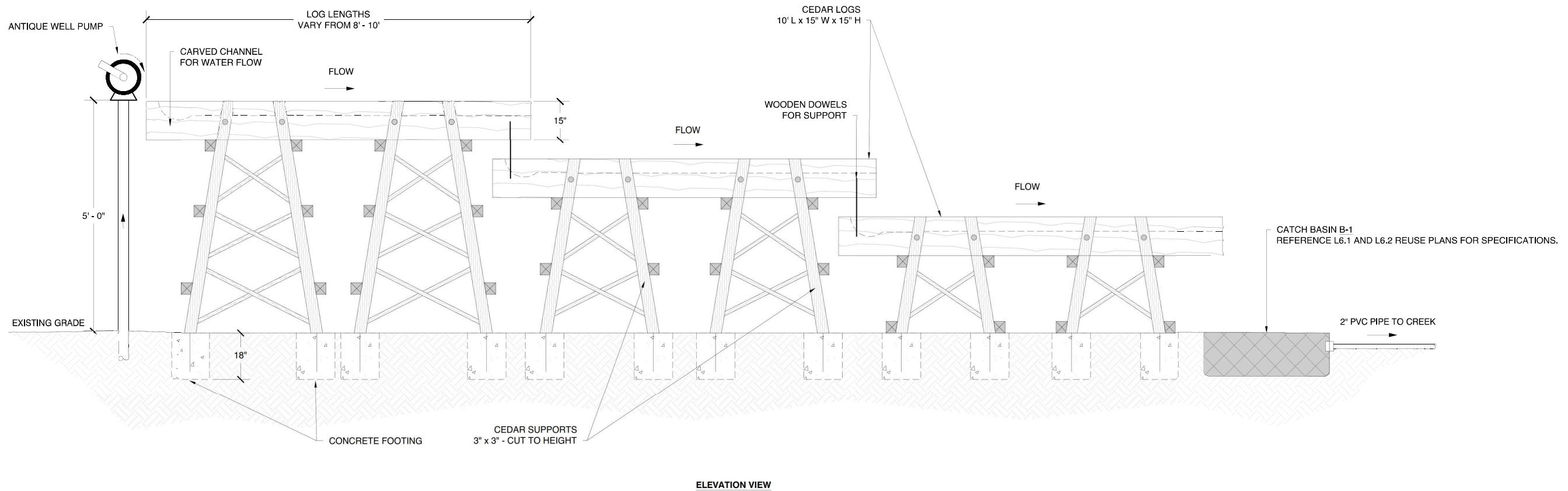

Twain Heart Meadows Park  
 22945 Meadow Drive, Twain Harte, CA, 95383

REVISION	DATE
1 60% DRAFT TO CSD	05.31.22
2 60% TO CSD	06.15.22
3 60% TO SWB	07.28.22
4 100% TO CSD	12.14.22
5 100% TO CSD	04.28.23
6 100% TO CSD	06.07.23

DESIGN BY: SS,MS  
 DRAWN BY: MS  
 REVIEW BY: JPB

© 2023 Watershed Progressive. The design ideas and plans represented by these documents are the property of Watershed Progressive. Use or copy is permitted by contract only. The use or revisions of these ideas or plans is prohibited without the written permission of Watershed Progressive.

WATER REUSE AND UTILITIES DETAILS

L6.6

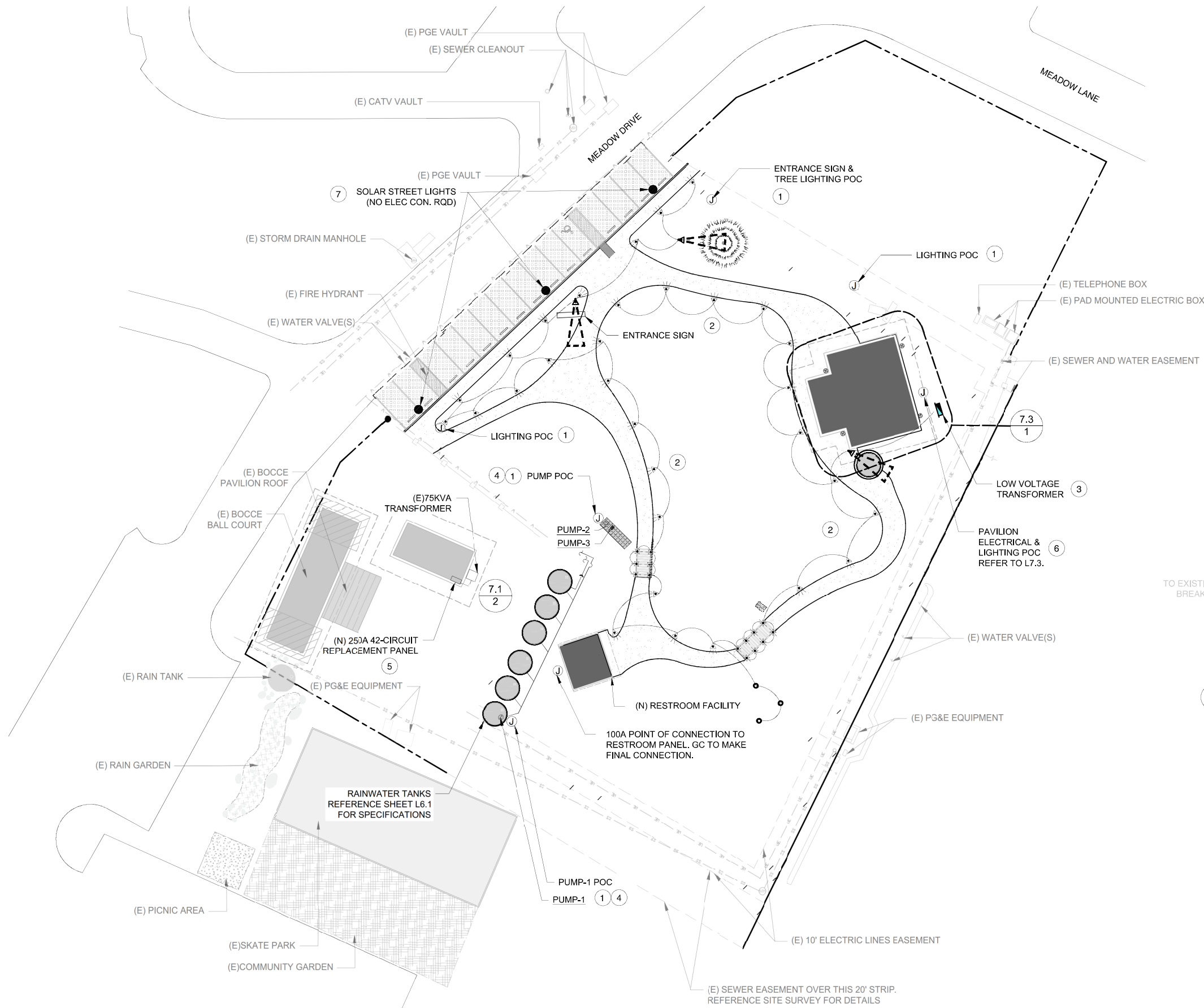

GENERAL NOTES

- A. ALL EXISTING ACTIVE UTILITIES WORK SHALL BE AVOIDED AND PROTECTED WHEN NECESSARY THROUGHOUT CONSTRUCTION.
- B. 811 - KNOW WHAT'S BELOW - CALL BEFORE YOU DIG
- C. TRENCHING FOR ALL ELECTRICAL WORK SHALL BE COORDINATED WITH ALL DISCIPLINES INCLUDING BUT NOT LIMITED TO REUSE PLANS, PATHWAY AND MATERIALS PLANS.
- D. CONTRACTOR SHALL COORDINATE ALL OUTAGES WITH PG&E AND TWIN HARTE CSD.



LEGEND

- PROPERTY BOUNDARY
- ▒ EXISTING BUILDING
- PROPOSED BUILDING
- - - BUILDING OFFSET
- UE — UNDERGROUND ELECTRIC
- ~ LOW VOLTAGE WIRE
- ⊙ PATHWAY LIGHT
- ⊙ WELL LIGHT
- ⊙ UPLIGHT
- ⊙ BOARDWALK LED LIGHT STRIP
- ⊕ NEW ELECTRICAL POINT OF CONNECTION
- ▬ LANDSCAPE LIGHTING TRANSFORMER
- (E) EXISTING
- (N) NEW

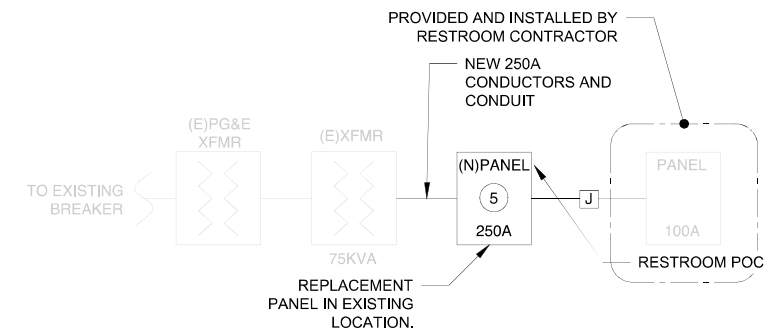

2 PARTIAL SINGLE LINE DIAGRAM

SHEET NOTES

- 1. GCFI RECEPTACLE. REFER TO DETAIL 2/L7.3. PROVIDE 3/4" CONDUIT AND CIRCUIT WITH (3)#12 WIRE.
- 2. PATHWAY LIGHTING PROVIDED, COORDINATED AND INSTALLED BY OTHERS. SPACING OF PATHWAY LIGHTS FOLLOW MANUFACTURER RECOMMENDATION AND OWNER INSTRUCTION. REFER TO L7.2 FOR SCHEDULE INFORMATION.
- 3. GC TO PROVIDE CONNECTION TO LOW VOLTAGE TRANSFORMER. ALL LOW VOLTAGE WIRING AND FIXTURES BY OTHERS. WIRE ROUTES ARE SHOWN FOR DESIGN INTENT.
- 4. GC TO PROVIDE ELECTRICAL POINT OF CONNECTION TO RECEPTACLES. ALL FINAL CONNECTIONS TO ELECTRICAL PUMP EQUIPMENT SHALL BE COMPLETED BY WP. REFER TO L6 SERIES FOR PUMP SCHEDULES.
- 5. GC TO REPLACE (E) 200A HIGH LEG B PANEL WITH NEW 250A 42-CIRCUIT PANEL. RECONNECT 11 EXISTING CIRCUITS. EXISTING CONDUIT AND WIRE TO REMAIN. CONNECT ALL NEW CIRCUITS TO NEW 250A PANEL. WHILE PG&E SHUT DOWNS ARE ACCEPTABLE, ANY WORK THAT REQUIRES INPUT OR CONSTRUCTION BY PG&E IS TO BE AVOIDED AND SHALL BE BROUGHT TO OWNER'S ATTENTION PRIOR TO MOVING FORWARD.
- 6. GC TO PROVIDE (3) DEDICATED 20A SINGLE-PHASE CIRCUITS.
- 7. GC TO PROVIDE, ASSEMBLE AND INSTALL SOLAR STREET LIGHTS. REFER TO LIGHTING SCHEDULE.

REVISION	DATE
1 60% DRAFT TO CSD	05.31.22
2 60% TO CSD	06.15.22
3 60% TO SWB	07.28.22
4 100% TO CSD	12.14.22
5 100% TO CSD	04.28.23
6 100% TO CSD	06.07.23

DESIGN BY: ABR  
DRAWN BY: DR. MS  
REVIEW BY: NS

© 2023 Watershed Progressive. The design ideas and plans represented by these documents are the property of Watershed Progressive. Use or copy is prohibited without the written permission of Watershed Progressive.







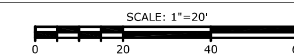

LIGHTING AND ELECTRICAL PLAN

L7.1

100% CD



**LIGHTING SCHEDULE**

SYMBOL	MANUFACTURER/MODEL/DESCRIPTION	QTY
	TRANSFORMER 24V - TRANSFORMER	1
	PATHWAY LIGHTS FOCUS INDUSTRIES PL-23-DM-24-BAR	31
	WELL LIGHTS SPJ-MW1000-P-RB CAST BRASS, AGED BRASS (AG), GRADE LEVEL LAMP: FB-2W-TA16, 2W2VA, 2200K	3
	LED LIGHT FOR BOARDWALK IP65-UB-AT1-30K97C OUTDOOR (IP65) ULTRABRIGHT™ ACCENT SERIES LED STRIP LIGHT - 3.5 WATTS/FT	60 lf
	UP-LIGHTS FOCUS INDUSTRIES RXD-01-BAR	3
	SOLAR STREET LIGHTS HAPCO 12' SOLAR POLE, DIRECT BURY	3
	PAVILION - PENDANT LIGHTS SPJ LIGHTING SPJ-49-05	10
	PAVILION - WELL LIGHTS SPJ LIGHTING SPJ-CBWL-16	2

**ELECTRICAL GENERAL NOTES**

- THIS PLAN IS INTENDED FOR LANDSCAPE LIGHTING PURPOSES ONLY. ALL LIGHTING FIXTURES AND TRANSFORMERS SHALL BE INSTALLED BY A LICENSED ELECTRICIAN PER MANUFACTURER'S SPECIFICATIONS. IT IS THE CONTRACTORS RESPONSIBILITY TO MAINTAIN COMPLIANCE WITH ALL LOCAL BUILDING AND ELECTRICAL SAFETY CODES AND ORDINANCES.
- FIXTURES ARE SHOW IN APPROXIMATE LOCATION. THE CONTRACTOR SHALL FIELD VERIFY THE ACTUAL PLACEMENT OF EACH FIXTURE UPON COMPLETION OF LANDSCAPE INSTALLATION.
- ALL PATH LIGHTS ARE TO BE INSTALLED AT A MINIMUM OF 12-INCHES FROM ANY SIDEWALK OR VERTICAL STRUCTURE.
- ALL LOW-VOLTAGE DIRECT BURIAL WIRE TO BE INSTALLED AT >=6" BELOW FINISH GRADE PER ELECTRICAL CODE.
- IN ORDER TO MINIMIZE FUTURE DISTURBANCE, ALL WIRE RUNS SHALL BE INSTALLED PARALLEL AND ADJACENT TO HARD SURFACES SUCH AS SIDEWALKS DRIVEWAYS AND WALLS.
- THE CONTRACTOR SHALL BE RESPONSIBLE FOR INSTALLING SLEEVES UNDER ALL HARDSCAPE SURFACES USING A MINIMUM 1-INCH PVC PIPE.
- ALL UNDERGROUND SPLICES SHALL BE UL-486RATED AND INSTALLED IN UNDERGROUND J-BOXES WITH WATER TIGHT CONNECTIONS LEAVING 12-INCHES OF EXCESS WIRE SLACK.
- ALL EXTERIOR 120-VOLT ELECTRICAL OUTLETS SHALL BE GFI-PROTECTED AS PER NATIONAL ELECTRICAL CODE.
- ALL TRANSFORMERS PLUGGED INTO AN OUTDOOR RECEPTACLE SHALL HAVE AN "IN USE" COVER. CONTRACTOR SHALL INSTALL TAYMAC TYPE COVERS AT ALL OUTLETS.
- ALL PLUG-IN TRANSFORMERS SHALL HAVE A DRIP LOOP IN THE POWER CORD.
- ALL EXPOSED CONDUITS SHALL BE PAINTED TO MATCH SURROUNDINGS.
- THE INSTALLING CONTRACTOR SHALL BE RESPONSIBLE FOR ADJUSTING THE FIXTURES AT NIGHT TO HELP ELIMINATE GLARE AND TO ENSURE OPTIMUM LIGHTING EFFECT.
- CONTRACTOR TO VERIFY A MINIMUM OF 10-VOLTS AT THE LAST FIXTURE FOR OPTIMAL OPERATION.
- CONTRACTOR TO CENTER FEED THE SYSTEM WHEN AT ALL POSSIBLE AND VERIFY ALL WIRE CONNECTIONS ARE AT THE FIXTURES.
- ALL WIRE CONNECTIONS AT FIXTURES SHALL BE MADE USING WATER TIGHT CONNECTIONS.



Twain Harte Meadows Park  
22945 Meadow Drive, Twain Harte, CA, 95383

**PANEL SCHEDULE**

Branch Panel: NEW WELL HOUSE PANEL											
Location:			Volts: 240 DELTA HI LEG			A.I.C. Rating: 100 kAIC					
Supply From:			Phases: 3			Mains Type: MCB					
Mounting: Surface			Wires: 4			Mains Rating: 250 A					
Enclosure: NEMA 3R						MCB Rating: 250 A					
<b>Notes:</b> PROVIDE NEMA 3R FUSED DISCONNECT ON PRIMARY SIDE OF 75 KVA TRANSFORMER. PROVIDE BUSSMAN TYPE FR3-R, 125 A FUSES OR SIMILAR.											
CKT	Circuit Description	Trip	Poles	A	B	C	Poles	Trip	Circuit Description	CKT	
1	Gazebo Light (EX)	20 A	1	1000...	1500...		1	15 A	CL2 (EX)	2	
3	Space - High Leg	--	1		--	--	1	--	Space - High Leg	4	
5	Water Tank (EX)	20 A	1			1500...   500 VA	1	15 A	Interior Lights (EX)	6	
7	Exterior Lights (EX)	20 A	1	1500...   1500...			1	20 A	Exhaust Fan (EX)	8	
9	Space - High Leg	--	1		--	--	1	--	Space - High Leg	10	
11	Pavilion Lighting - New	20 A	1			0 VA   720 VA	1	20 A	Wall Receptacle (EX)	12	
13	Pavilion Receptacles Rear - New	20 A	1	360 VA   3333...			3	70 A	Well Pump (EX)	14	
15	Space - High Leg	--	1		--	3333...	--	--	--	16	
17	Pavilion Receptacles Front - New	20 A	1			540 VA   3333...	--	--	--	18	
19	Water Pump 2 - New	20 A	1	1000...   1000...			1	20 A	Water Pump 1 - NEW	20	
21	Space - High Leg	--	1		--	--	1	--	Space - High Leg	22	
23	Water Pump 3 - New	20 A	1			1000...   500 VA	1	15 A	Generator Batter (EX)	24	
25	Restroom Building Connection - New	100 A	3	6933...   360 VA			1	20 A	Park Receptacles (2) - New	26	
27	--	--	--		6933...	--	1	--	Space - High Leg	28	
29	--	--	--			6933...   540 VA	1	20 A	Park Receptacles (2) - New	30	
31	Spare	20 A	1	0 VA   540 VA			1	30 A	Quad Outlet Connection - New	32	
33	Space - High Leg	--	1		--	--	1	--	Space - High Leg	34	
35	Spare	20 A	1			0 VA   0 VA	1	20 A	Spare	36	
37	Spare	20 A	1	0 VA   0 VA			1	20 A	Spare	38	
39	Space - High Leg	--	1		--	--	1	--	Space - High Leg	40	
41	Spare	20 A	1			0 VA   0 VA	1	20 A	Spare	42	
<b>Total Load:</b>				19027 VA	10267 VA	15567 VA					
<b>Total Amps:</b>				159 A	86 A	130 A					
<b>Legend:</b>											
<b>Notes:</b> Note - Panel has a high leg - Verify high leg in panel prior to connection - do not circuit single phase connections to high leg											

REVISION	DATE
1 60% DRAFT TO CSD	05.31.22
2 60% TO CSD	06.15.22
3 60% TO SWB	07.28.22
4 100% TO CSD	12.14.22
5 100% TO CSD	04.28.23
6 100% TO CSD	08.07.23

DESIGN BY: ABR  
DRAWN BY: DR. MS  
REVIEW BY: NS

© 2023 Watershed Progressive. The design ideas and plans represented by these documents are the property of Watershed Progressive. Use or copy is permitted by contract only. The use or revisions of these ideas or plans is prohibited without the written permission of Watershed Progressive.

**LIGHTING AND ELECTRICAL NOTES**

**L7.2**

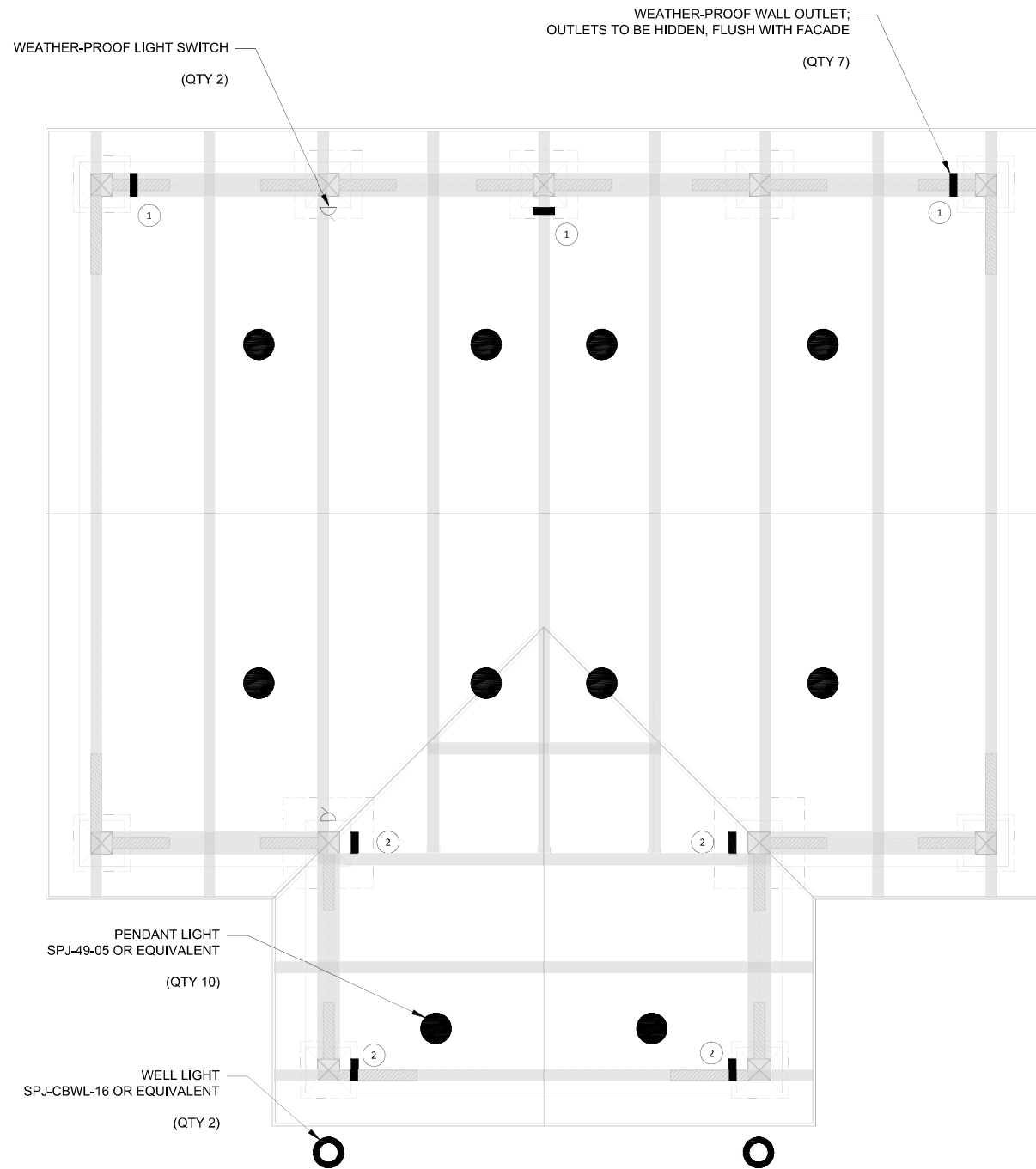

- GENERAL NOTES:**
- GC TO PROVIDE FULL LIGHTING AND ELECTRICAL SCOPE WITHIN PAVILION.
  - EXACT FIXTURE LOCATION TO BE COORDINATED WITH OWNER'S REPRESENTATIVE AND CONSTRUCTION DISCIPLINES PRIOR TO INSTALLATION.
  - ALL ELECTRICAL FIXTURES SHALL BE WEATHERPROOF.
  - PROVIDE EXTERIOR-RATED, METAL CONDUIT TO ALL FIXTURES.
  - ALL OUTLETS SHALL BE MOUNTED FLUSH WITH FINISHED STONE FACADE ON POSTS.
  - PROVIDE LOCKING COVERS FOR ALL OUTLETS AND SWITCHES.
  - COORDINATE ALL SITE ELECTRICAL ROUTING WITH TRENCHING CONSTRUCTION.
  - CIRCUIT NUMBERING IS FOR REFERENCE.
  - CIRCUIT ALL ELECTRICAL FIXTURES TO PANEL IN WELL HOUSE. ROUTE CONDUIT UNDERGROUND TO SERVE PAVILION. COORDINATE WITH FOUNDATION AND CONCRETE VENDOR FOR EXACT LOCATIONS PRIOR TO POUR.

- DETAIL NOTES:**
- CONNECT TO CIRCUIT 1.
  - CONNECT TO CIRCUIT 2.

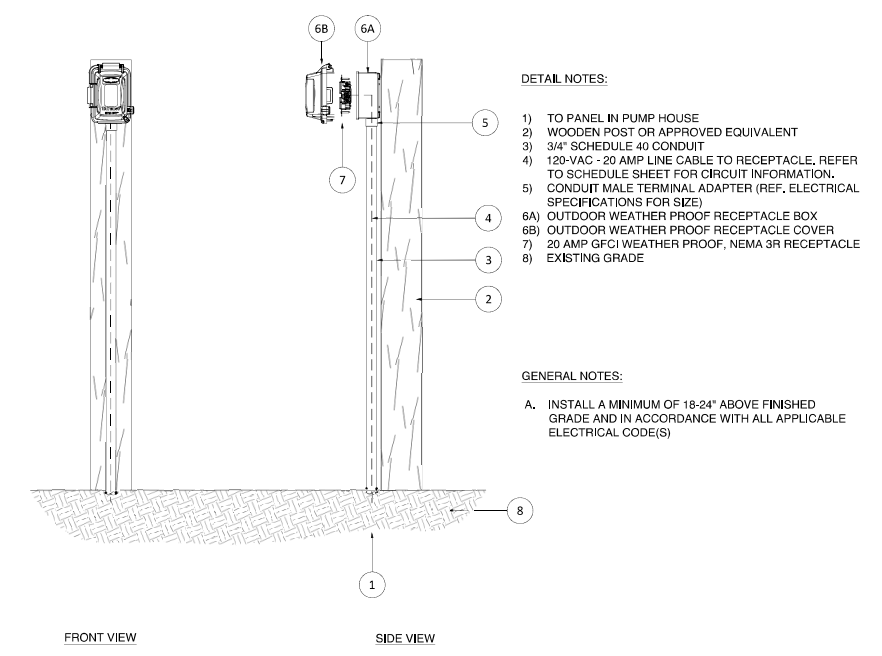

**2 OUTDOOR WEATHER PROOF (GFCI) RECEPTACLE ASSEMBLY (TYP)**  
NOT TO SCALE

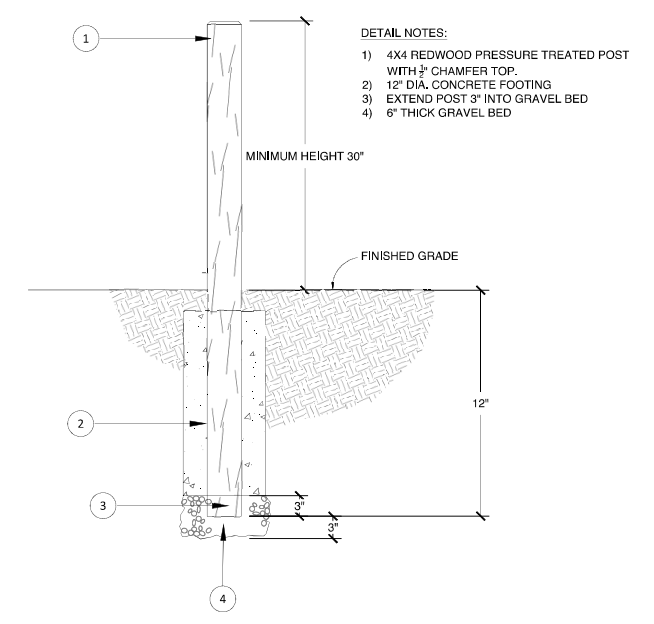

**1 OUTDOOR WEATHER PROOF (GFCI) RECEPTACLE ASSEMBLY (TYP)**  
NOT TO SCALE

Twain Harte Meadows Park  
 22945 Meadow Drive, Twain Harte, CA, 95383

DATE: PROJECT NO.

REVISION	DATE
1 60% DRAFT TO CSD	05.31.22
2 60% TO CSD	06.15.22
3 60% TO SWB	07.28.22
4 100% TO CSD	12.14.22
5 100% TO CSD	04.28.23
6 100% TO CSD	06.07.23

DESIGN BY: ABR  
 DRAWN BY: DR. MS  
 REVIEW BY: NS

© 2023 Watershed Progressive. The design ideas and plans represented by these documents are the property of Watershed Progressive. Use or copy is permitted by contract only. The use or revisions of these ideas or plans is prohibited without the written permission of Watershed Progressive.

**LIGHTING AND ELECTRICAL DETAILS**

**L7.3**

**3 PAVILION LIGHTING & ELECTRICAL LAYOUT**  
NOT TO SCALE

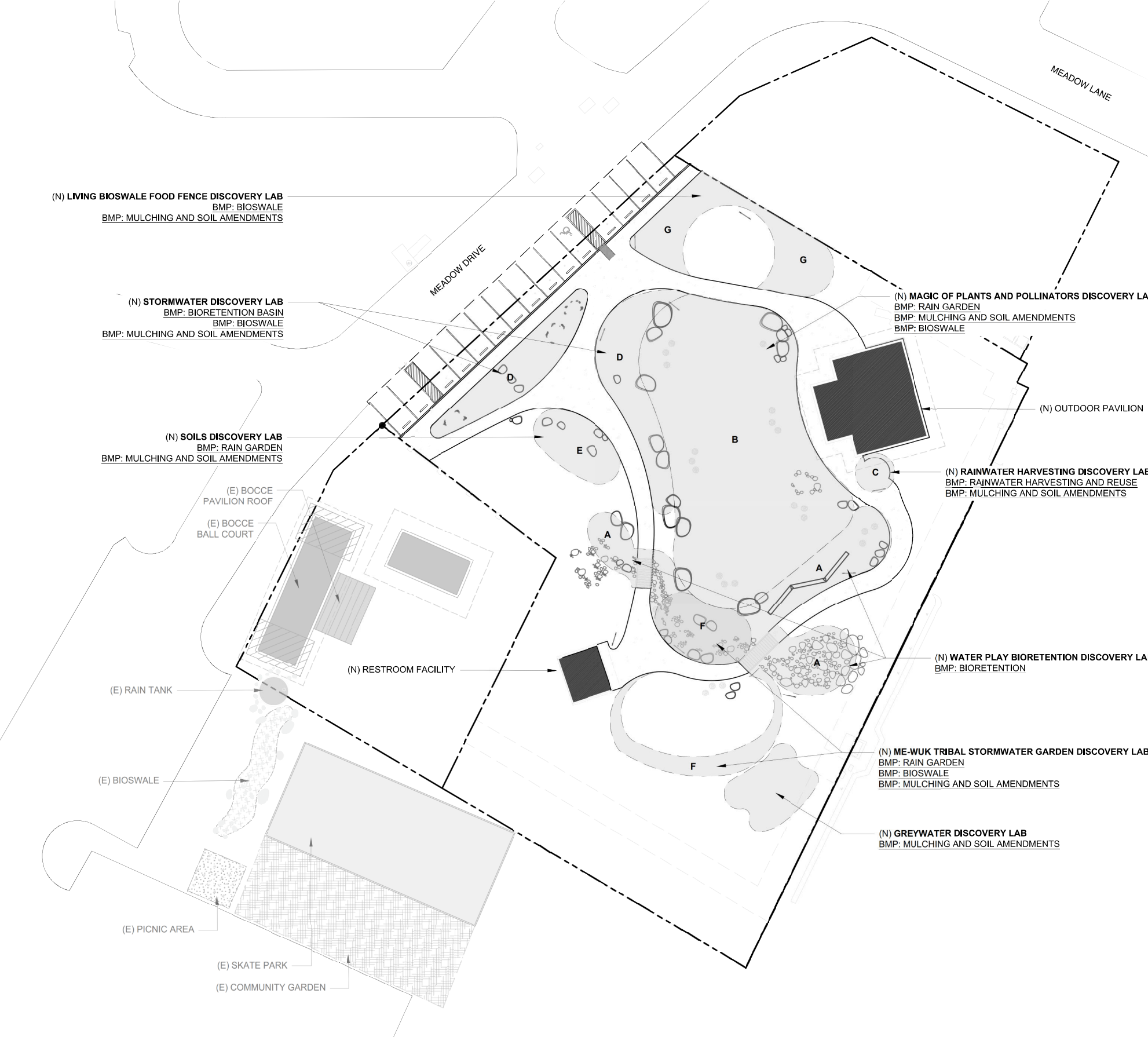

**DISCOVERY LAB NOTES**

**A. WATER PLAY BIORETENTION DISCOVERY LAB:**

LEARNING THROUGH PLAY ABOUT THE VALUE OF CLEAN ABUNDANT WATER FOR RECREATION, AND THE DELICATE BALANCE OF HUMAN NEEDS, AND ECOSYSTEM HEALTH.

THE WATER PLAY BIORETENTION DISCOVERY LAB MIMICS NATURAL SPRINGS AND RIVERS. THIS FEATURE PROVIDES THE COMMUNITY RELIEF FROM HOT WHETHER WHILE DEMONSTRATING THE IMPORTANCE OF CLEAN WATER FOR RECREATION AND ECOSYSTEM NEEDS. THE LINK TO THE STORM WATER RAINGARDEN DISCOVERY LAB PROVIDES AN INTERACTIVE UNDERSTANDING OF HOW HUMANS AND THE REST OF THE ECOSYSTEM RELY ON THE SAME WATER SOURCES. THE PATH ALONG THIS DISCOVERY LAB INCLUDES STEPPING STONE PAVERS WITH PRINTS OF IMPORTANT PLANTS FOR THE WATERSHED AND ANIMAL TRACKS OF LOCAL SPECIES WITH THEIR NAMES IN ENGLISH AND ME-WUK. NATIVE PLANTINGS AROUND THE PLAY AREA GIVE VISITORS AND OPPORTUNITY TO BECOME MORE FAMILIAR WITH THE IMPORTANCE OF THE LOCAL ECOSYSTEM WHILE ENJOYING THE PARK. SIGNAGE WITH QR CODES WILL LINK VISITORS TO MORE INFORMATION FROM SITES LIKE THESE: [HTTPS://MEWUK.COM/CULTURAL/TRADITIONAL/](https://MEWUK.COM/CULTURAL/TRADITIONAL/)

- BENEFITS INCLUDE:**
- STORMWATER QUALITY IMPROVEMENT
  - HABITAT ENHANCEMENT
  - REDUCED FLOOD RISK

**B. MAGIC OF PLANTS AND POLLINATORS DISCOVERY LAB:**

HANDS-ON SCIENCE THROUGH OBSERVATION AND MONITORING.

PLANTS THAT PROVIDE FOOD AND HABITAT FOR IMPORTANT POLLINATORS ARE ALONG THE EDGE OF THE MEADOW NEAR BOULDERS WHERE VISITORS CAN SIT AND OBSERVE OR MONITOR POLLINATORS BY PARTICIPATING IN CITIZEN SCIENCE POLLINATOR COUNTS. THE USE OF STORMWATER BIOFILTRATION AND STORMWATER ABSORPTION TO SUPPORT HEALTHY PLANT LIFE AS A BEDROCK OF A POLLINATOR ECOSYSTEM IS HIGHLIGHTED. POLLEN-PRODUCING PLANTS GIVE POLLINATORS EASY ACCESS TO NUTRIENT-RICH FOOD SOURCES. BETWEEN 75% AND 95% OF ALL FLOWERING PLANTS RELY ON POLLINATORS. POLLINATOR-FRIENDLY PLANTS TREAT STORMWATER RUNOFF BY ACTING AS A PHYSICAL FILTER FOR POLLUTANTS, ABSORBING MICRO-POLLUTANTS, AND PROVIDING EROSION CONTROL AS THEIR COMPLEX ROOT SYSTEMS STABILIZE SOIL. FLOWERING PLANTS ALSO REDUCE SOIL EROSION BY DISSIPATING THE ENERGY FROM RAINDROP IMPACT WITH THEIR FOLIAGE. IN THIS WAY, THESE POLLINATOR-FRIENDLY PLANTS REDUCE THE AMOUNT OF SEDIMENT, WHICH IS THE MOST COMMON POLLUTANT IN STREAMS, THAT REACHES TWAIN HARTE CREEK.

- BENEFITS INCLUDE:**
- HABITAT ENHANCEMENT
  - STORMWATER QUALITY IMPROVEMENT
  - ENHANCED SOIL HEALTH

**C. RAINWATER HARVESTING DISCOVERY LAB:**

LEARNING THROUGH OBSERVATION OF DEMONSTRATED AND CONNECTIONS.

WATER USE AT THE PAVILION IS TIED TO HOW HUMANS PARTICIPATE IN THE WATER CYCLE AND CAN CREATE A MORE SUSTAINABLE SMALL WATER CYCLE AT HOME. WATER OFF THE PAVILION ROOF IS CAPTURED AND STORED IN RAIN TANKS. THIS WATER IS REUSED FOR IRRIGATION. THIS DEMONSTRATION SHOWS HOW RAINWATER HARVESTING CAN HELP REDUCE SOIL EROSION AND FLOODING WHILE PROVIDING WATER SECURITY.

- BENEFITS INCLUDE:**
- REDUCED FLOOD RISK
  - STORMWATER QUALITY IMPROVEMENT
  - ENHANCED WATER SECURITY
  - REDUCED CONSUMPTIVE USE

**D. STORMWATER DISCOVERY LAB:**

HANDS-ON LEARNING THROUGH OBSERVATION AND PLAY COMBINED WITH CONCEPTUAL LEARNING FROM SIGNAGE.

PLANTS THAT CLEAN STORMWATER AND REMOVE HYDROCARBONS ARE FEATURED IN THIS AREA. BOULDERS TO SIT AND OBSERVE LOCAL FLORA AND FAUNA WILL BE PLACED IN KEY LOCATIONS. SIGNAGE WILL REVEAL THE MAGIC OF PLANTS AND INFILTRATION HAPPENING BELOW GROUND AS WELL AS QR CODES LINKED TO WATERTOOLKIT.COM TO LEARN MORE. ADDITIONALLY AN EXPERIENCE OF LOCAL WATER DISTRIBUTION IS INCORPORATED THROUGH A FLUME PLAY FEATURE. A HAND PUMP INVITES CHILDREN TO SEE HOW WATER IS PULLED OUT OF THE GROUND AND TRANSPORTED BY THE FLUME. WHEN THE PUMP IS IN USE THE WATER FLOWING THROUGH THE WATER PLAY BIORETENTION DISCOVERY LAB IS REDUCED, DEMONSTRATING THE DIRECT CONNECTION BETWEEN HUMAN USES AND ECOSYSTEM HEALTH.

- BENEFITS INCLUDE:**
- HABITAT ENHANCEMENT
  - STORMWATER QUALITY IMPROVEMENT
  - REDUCED FIRE RISK
  - ENHANCED WATER SECURITY
  - ENHANCED SOIL HEALTH

**E. SOILS DISCOVERY LAB:**

HANDS-ON LEARNING ABOUT THE ROLE OF SOIL HEALTH IN WATER QUALITY THROUGH OBSERVATION AND ACTIVITIES.

THIS DISCOVERY LAB HIGHLIGHTS THE IMPORTANCE OF SOIL HEALTH IN ECOLOGICAL RESILIENCE AND ESPECIALLY WATER QUALITY. METHODS OF IMPROVING SOIL HEALTH SUCH AS MULCHING ARE DEMONSTRATED ALONG WITH SOIL SAMPLES THAT GIVE VISITORS EXPERIENTIAL UNDERSTANDING OF WHAT HEALTHY LIVING SOIL LOOKS LIKE. THIS REVEALS THE POSITIVE EFFECTS OF STORMWATER BIOFILTRATION AND STORMWATER INFILTRATION ON THE SITE. THE SOILS DISCOVERY LAB PROVIDES A LEARNING EXPERIENCE THAT DEMONSTRATES THE IMPORTANT FUNCTIONS OF HEALTHY SOIL. IN THE STORMWATER TREATMENT HAPPENING AT THE SITE [E.G., PROVIDING A MEDIA FOR VEGETATION, RETAINING POLLUTANTS THAT WOULD OTHERWISE END UP IN TWAIN HARTE CREEK, PROMOTES BIOLOGICAL ACTIVITY THAT BREAKS DOWN SOME POLLUTANTS, DESSICATION OF PATHOGENS ON THE SOIL SURFACE, CAPTURING AND RETAINING CARBON, HEALTHY SOILS MINIMIZE EROSION].

- BENEFITS INCLUDE:**
- HABITAT ENHANCEMENT
  - STORMWATER QUALITY IMPROVEMENT
  - REDUCED FIRE RISK
  - REDUCED FLOOD RISK
  - ENHANCED WATER SECURITY
  - ENHANCED SOIL HEALTH

**F. ME-WUK TRIBAL STORMWATER GARDEN DISCOVERY LAB:**

HANDS-ON EXPERIENCES OF ME-WUK ECOLOGICAL KNOWLEDGE AND SUSTAINABLE TECHNOLOGIES INCLUDING PASSIVE IRRIGATION THROUGH STORMWATER HARVESTING.

THIS STORMWATER GARDEN COLLECTS RUNOFF TO PASSIVELY IRRIGATE IMPORTANT PLANTS TO THE ME-WUK TRIBE. THESE PLANTS ARE ALSO INCLUDED THROUGHOUT THE SITE AND WOVEN INTO INTERPRETIVE AND EXPERIENTIAL LEARNING OPPORTUNITIES. TRIBAL CONSULTANTS WILL ADVISE ON FURTHER EFFORTS TO BRING IMPORTANT TRIBAL KNOWLEDGE AND FORMS OF KNOWING TO THE SITE EXPERIENCE.

- BENEFITS INCLUDE:**
- ME-WUK TRIBAL PLANT KNOWLEDGE
  - ENHANCED FOOD SECURITY
  - STORMWATER QUALITY IMPROVEMENT
  - ENHANCED SOIL HEALTH

**G. LIVING BIOSWALE FOOD FENCE DISCOVERY LAB:**

HANDS-ON LEARNING THROUGH FORAGING, OBSERVATION AND PLANT USE ACTIVITIES.

PLANTS THAT PROVIDE FOOD TO BOTH ANIMALS AND HUMANS ARE INCLUDED IN THIS AREA WHILE DEMONSTRATING VERTICLE GARDENING AND THE IMPORTANCE OF LOCAL FOOD SECURITY. CONNECTION IS MADE BETWEEN THE BIOFILTRATION OF STORMWATER THROUGH ME-WUK STORMWATER GARDEN DISCOVERY LAB AND THE LOCAL AND HISTORICAL USES OF BIOFILTERED STORMWATER. THIS IS MADE EXPLICIT THROUGH THE FACT THAT THE FOOD FENCE IS IRRIGATED BY FILTERED STORMWATER AT THE ADJACENT ME-WUK TRIBAL STORMWATER GARDEN DISCOVERY LAB.

- BENEFITS INCLUDE:**
- ME-WUK TRIBAL PLANT KNOWLEDGE
  - ENHANCED FOOD SECURITY
  - STORMWATER QUALITY IMPROVEMENT
  - ENHANCED SOIL HEALTH



Twain Harte Meadows Park  
22945 Meadow Drive, Twain Harte, CA, 95383

REVISION	DATE
1 60% DRAFT TO CSD	05.31.22
2 60% TO CSD	06.15.22
3 60% TO SWB	07.28.22
4 60% TO SWRCB	08.19.22
5 100% TO CSD	12.14.22
6 100% TO CSD	04.28.23
7 100% TO CSD	06.07.23

DESIGN BY: ABR  
DRAWN BY: DR. JS. MS  
REVIEW BY: RH, NS, JPB

© 2023 Watershed Progressive. The design ideas and plans represented by these documents are the property of Watershed Progressive. Use or copy is permitted by contract only. The use or revisions of these ideas or plans is prohibited without the written permission of Watershed Progressive.

**DISCOVERY LABS KEY PLAN**

**L8.1**

100% CD

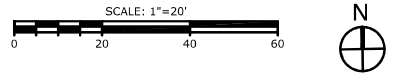

PUMP SCHEDULE							
TAG NUMBER	DESCRIPTION	LOCATION	PERFORMANCE			MAKE, MODEL	QTY
			FLOW	TOTAL DEVELOPED HEAD	POWER		
			GPM	(FT)	(HP TOTAL)		
PUMP-1	SUBMERSIBLE RW PUMP	REFER TO PLANS	25	150	1.5	GRUNDFOS, SBA 3-45	1

RAINWATER TANK SCHEDULE						
TAG NUMBER	LOCATION	VOLUME	DIMENSIONS		MAKE, MODEL	QTY
		(GROSS GAL.)	(DIA. X H)			
TANK-1	REFER TO PLANS	5,000	10' X 7'-6"		BH CLASSIC CORRUGATED, BH09X07 FRB	1

EQUIPMENT SCHEDULE				
TAG NUMBER	LOCATION	DESCRIPTION	QTY	
FIL-1	(1) AT EACH DOWNSPOUT	FIRST FLUSH FILTER ASSEMBLY	4	
BT-1	AT TANK LOCATION	BATTERY OPERATED TIMER	1	

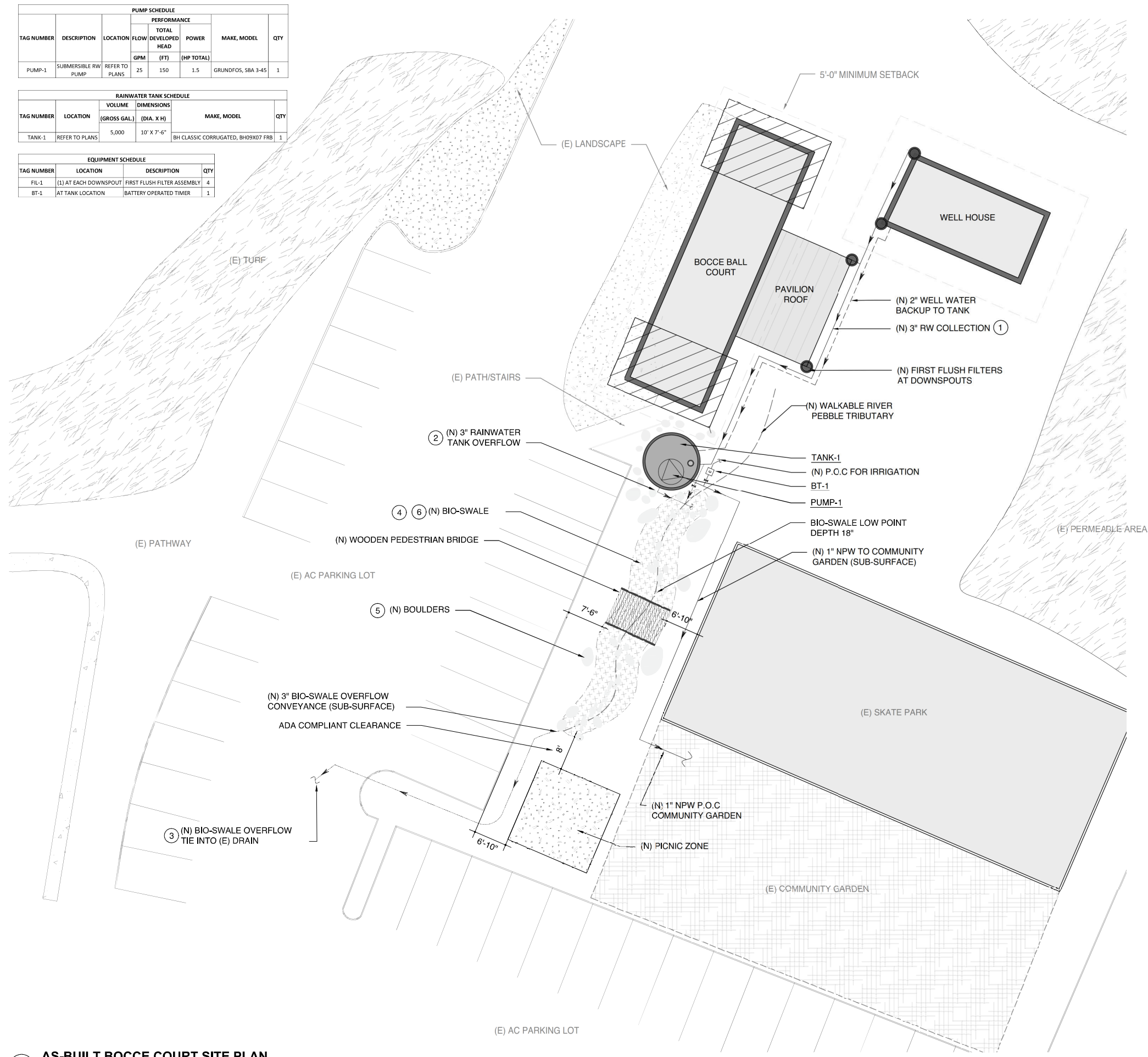

PROJECT SUMMARY

AS ONE OF THE FIRST PARTS OF A MULTI PHASED COMMUNITY ENHANCEMENT PROJECT FOR THE TOWN OF TWAIN HARTE, A BOCCÉ BALL COURT WAS RECENTLY BUILT NEAR THE EXISTING THOCS WELLHOUSE AND COMMUNITY SKATEPARK WITH A NEW SHADE PAVILION AND SEATING AREA. TO DEMONSTRATE RESPONSIBLE STORMWATER MANAGEMENT PRACTICES, IT WAS DECIDED THAT THE RAINWATER FROM THE 360SQFT SHADE PAVILION AND 400SQFT WELLHOUSE WOULD BOTH BE DIRECTED INTO A 4,333 GALLON CORRUGATED STEEL RAINWATER CISTERN BY ATTACHING CONVEYANCE PIPES TO THE DOWNSPOUTS OF EACH ROOF. FIRST FLUSH DEVICES WERE INSTALLED AT EACH DOWNSPOUT TO PREFILTER THE WATER BEFORE IT ENTERS THE CISTERN. THE RAINWATER CISTERN CONTAINS A SUBMERSIBLE PUMP WHICH PRESSURIZES THE WATER FOR USE IN THE NEARBY COMMUNITY GARDEN AND SURROUNDING DRIP IRRIGATION. A BIO-SWALE WAS BUILT BELOW THE CISTERN TO CONTROL AND INFILTRATE THE OVERFLOW OF RAINWATER WHEN THE TANK BECOMES FULL. AT THE END OF THE BIO-SWALE, WHICH EMULATES A SMALL CREEK BED, THERE IS A DRAIN INLET LEADING TO THE EXISTING UNDERGROUND STORM DRAIN TO PREVENT THE BIO-SWALE FROM OVERFLOWING AND CAUSING FLOODING ISSUES. DURING A COMMUNITY VOLUNTEER DAY, THE BIO-SWALE AND AREAS SURROUNDING THE SHADE PAVILION AND CISTERN WERE PLANTED WITH CALIFORNIA NATIVE PLANTS AND TREES TO CREATE MORE SHADE, ENHANCE AESTHETICS, AND BUILD SOIL HEALTH. COMPOST AND WOOD CHIP MULCH WERE ALSO ADDED TO FURTHER ENHANCE SOIL HEALTH AND MOISTURE RETENTION. AN EDUCATIONAL WORKSHOP WAS CONDUCTED AND AN INTERPRETIVE SIGN WAS INSTALLED TO EXPLAIN THE BENEFITS OF RAINWATER HARVESTING AND PROPER STORMWATER MANAGEMENT. A UNIQUE ADDITION TO THIS RAINWATER COLLECTION SYSTEM IS THE ADDITION OF BACKFLUSH WATER FROM THE WELLHOUSE. AS ROUTINE MAINTENANCE, THE THOCS BACKFLUSHES THE WELL LINES TO REMOVE SEDIMENT, THIS WATER IS RELATIVELY CLEAN, CONTAINING A SMALL AMOUNT OF SEDIMENT BUT COMPARABLE IN QUALITY TO THE RAINWATER COLLECTED FROM THE ROOF AND WAS PREVIOUSLY BEING FLUSHED DOWN THE DRAIN IN THE PROCESS. IT NOW ACTS AS ADDITIONAL INPUT INTO THE CISTERN AND IS USED AS NON-POTABLE IRRIGATION DURING TIMES WHEN THE RAINWATER SUPPLY IN THE TANK IS EXHAUSTED.

SHEET NOTES

1. RAINWATER COLLECTED FROM BOCCÉ BALL PAVILION STRUCTURE, WELL HOUSE AND CONVEYED TO RAINWATER TANK.
2. RAINWATER TANK OVERFLOW TO BE DIVERTED SUBSURFACE INTO PROPOSED BIO-SWALE.
3. BIO-SWALE OVERFLOW TO BE CONVEYED SUBSURFACE AND TIE INTO EXISTING DRAIN.
4. BIO-SWALE WILL BE PROVIDED WITH NATIVE, CLIMATE APPROPRIATE PLANTINGS.
5. ALL BOULDER PLACEMENT SHALL BE COORDINATED AND DETERMINED IN THE FIELD BY PROJECT LEAD.
6. ALL GRADING FOR BIO-SWALE SHALL BE COORDINATED AND DETERMINED IN THE FIELD BY PROJECT LEAD.

LEGEND

- PARCEL BOUNDARY
- MINIMUM SETBACK LINE
- CONTOURS
- RAINWATER (RW) CONVEYANCE
- PUMPED CONVEYANCE WATER
- ⊙ PUMP
- DIRECTION OF FLOW
- PIPE CONTINUATION
- ▭ EXISTING BUILDING
- RAINWATER TANK
- ▨ BIO-SWALE
- FILTRATION EQUIPMENT
- ⊠ BATTERY OPERATED CONTROLLER
- BOULDERS
- P.O.C POINT OF CONNECTION
- E EXISTING
- N NEW

WATERSHED PROGRESSIVE  
 WWW.WATERSHEDPROGRESSIVE.COM  
 209.732.0018  
 CENTRAL SIERRA OFFICE  
 1863 MAIN STREET  
 GROVELAND, CALIFORNIA 95321  
 OJAI OFFICE  
 288 N. SIGNAL ST., SUITE 5  
 OJAI, CALIFORNIA 93023

TWAIN HARTE BOCCÉ BALL COURT  
 STORMWATER ENHANCEMENT PROJECT

DATE:	05.24.21
PROJECT NO.	--
ISSUANCE	DATE
1 AS-BUILT	9.30.21
2	
3	
4	
5	
6	

DESIGN BY: JW, MS  
 DRAWN BY: MS  
 REVIEW BY: RH

AS-BUILT  
 BOCCÉ COURT  
 SITE PLAN

L9.1

AS-BUILT RECORD  
 NOT FOR CONSTRUCTION

1 AS-BUILT BOCCÉ COURT SITE PLAN

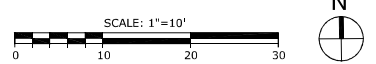

# PAVILION AND PERGOLA PLAN

## TWAIN HARTE COMMUNITY SERVICE DISTRICT

### MEADOW DRIVE

### TWAIN HARTE CA

#### PROJECT SCOPE

CONSTRUCT A HEAVY TIMBER FRAMED PAVILION WITH A CONCRETE SLAB

#### SITE INFORMATION

ADDRESS: MEADOW DRIVE  
TWAIN HARTE CA 95383

A.P.N.: 049-132-019

POWER: PG&E

LOT ELEVATION: 3650'

#### SHEET INDEX

- 1 TITLE NOTES
- 2 ELEVATION VIEWS
- 3 FOUNDATION PLAN, ROOF FRAMING PLAN
- 4 CROSS SECTIONS
- 5 DETAILS

#### BUILDING DIMENSIONS

BUILDING OCCUPANCY: U  
PAVILION AREA = 1400 SQ FT

#### SPECIAL INSPECTIONS

-NONE REQUIRED

#### PROJECT DESIGN DATA

GENERAL INFORMATION:  
RISK CATEGORY = II  
ROOF LIVE LOAD = 20 PSF  
ALLOWABLE SOIL BEARING CAPACITY = 1500 PSF

SNOW LOAD:  
ELEVATION = 3650'  
GROUND SNOW LOAD = 60 PSF

WIND DATA:  
BASIC WIND SPEED = V=95 MPH  
EXPOSURE CATEGORY = B

SEISMIC DATA:  
SEISMIC IMPORTANCE FACTOR = 1.0  
SPECTRAL RESPONSE ACCELERATION (SHORT PERIOD) = S<sub>s</sub>=0.385  
SPECTRAL RESPONSE ACCELERATION (1S) = S<sub>1</sub>=0.183  
SPECTRAL RESPONSE COEFFICIENT (SHORT PERIOD) = S<sub>0.2</sub>=0.383  
ANALYSIS PROCEDURE = EQ/LNT, L.TRL, FORCE D  
SEISMIC DESIGN CATEGORY = D  
SEISMIC FORCE RESISTING SYSTEM = CANTILEVERED COLUMN, TIMBER FRAME  
SEISMIC RESPONSE COEFFICIENT = C<sub>s</sub>=0.26  
RESPONSE MODIFICATION FACTOR = R=1.5

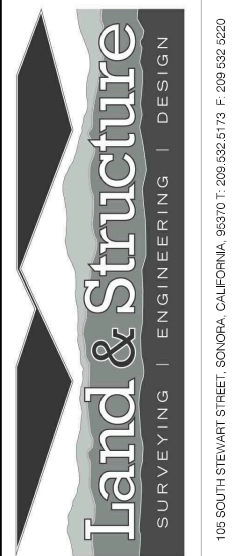

105 SOUTH STEWART STREET, SONORA, CALIFORNIA, 95370 T: 209.632.5173 F: 209.632.9220

#### SITE WORK NOTES

1. LAND & STRUCTURE HAS NOT MADE A GEOTECHNICAL REVIEW OF THE BUILDING SITE AND IS NOT RESPONSIBLE FOR GENERAL SITE STABILITY OR SOIL SUITABILITY FOR THE PROPOSED PROJECT.
2. BUILDING SITES ARE ASSUMED TO BE DRAINED AND FREE OF CLAY OR EXPANSIVE SOILS.
3. ALL FOOTINGS SHALL BE LEVEL OR STEPPED AND BEAR ON FIRM, STABLE, NATURAL, UNDISTURBED SOIL OR AN APPROVED COMPACTED FILL.
4. ALL FINISH GRADES SHALL SLOPE 5% AWAY FROM THE FOUNDATION (FOR A MINIMUM OF 10') AND DRAIN AWAY FROM BUILDING FOOTINGS. ADEQUATE DRAINAGE AWAY FROM THE STRUCTURE SHALL BE PROVIDED BY CONTRACTOR OR OTHERS.
5. THE CONTRACTOR SHALL BE RESPONSIBLE FOR ALL EXCAVATION PROCEDURES INCLUDING SHORING AND PROTECTION OF ADJACENT PROPERTY, STRUCTURES, STREETS, AND UTILITIES IN ACCORDANCE WITH THE LOCAL BUILDING DEPARTMENT. ANY DAMAGE TO AN EXISTING STRUCTURE AS A RESULT OF ANY ACTION OF THE CONTRACTOR SHALL BE REPAIRED AND/OR REPLACED AT THE CONTRACTORS EXPENSE.
6. ALL MATERIALS FROM DEMOLITION SHALL BE REMOVED FROM SITE AND DISPOSED OF BY THE CONTRACTOR, UNLESS OTHERWISE INSTRUCTED BY OWNER.
7. CONTRACTOR SHALL PROVIDE BARRICADES, WARNING SIGNS, ETC. AS REQUIRED BY LOCAL CODES.
8. CONTRACTOR SHALL LOCATE AND CLEARLY MARK THE LOCATION OF ALL UTILITIES PRIOR TO CONSTRUCTION.
9. CONTRACTOR SHALL BE RESPONSIBLE FOR LOCATING ALL NEW STRUCTURES AND UTILITIES ON PROPERTY AND COMPLYING WITH ALL SETBACKS.

#### WOOD FRAME NOTES

1. ALL FRAMING LUMBER SHALL BE DOUGLAS FIR-LARCH (DFL) AS FOLLOWS, UNLESS OTHERWISE NOTED.
2. 4x AND SMALLER FRAMING SHALL BE D.F. #2 U.N.O. 6x AND LARGER SHALL BE D.F. #2 U.N.O. INTERIOR NON-BEARING STUDS AND PLATES MAY BE CONSTRUCTION GRADE. PARALLEL STRAND LUMBER (PSL) SHALL BE 2.0E, Fd=2500 PSI LAMINATED VENEER LUMBER (LVL) SHALL BE 1.9E, Fd=2600 PSI GLUE LAMINATED BEAMS (GLULAMS) SHALL APA/EVS DOUGLAS FIR MARKED 24F-V4 FOR SIMPLE SPANS AND 24F-V8 FOR CANTILEVER OR MULTIPLE SPANS. GLULAMS TO BE 1.8E, Fd=2400 PSI GLULAMS EXPOSED TO WEATHER SHALL BE RATED FOR EXTERIOR USE BY THE MANUFACTURER OR AN APPROVED PROTECTION FROM THE EXPOSURE SHALL BE PROVIDED. GLULAMS SHALL BE ORDERED WITHOUT CAMBER UNLESS NOTED OTHERWISE. LOG COLUMNS AND BEAMS SHALL BE D.F. #2, 1.3E, Fb=875 PSI U.N.O.
3. ANY BOTTOM PLATE OR SOLE PLATE RESTING ON CONCRETE OR MASONRY SHALL BE PRESSURE TREATED DOUGLAS FIR.
4. ALL LUMBER SHALL BE STAMPED WITH THE GRADE MARK OF AN APPROVED LUMBER GRADING AGENCY.
5. SHEATHING- ALL PLYWOOD TO CONFORM TO APA STANDARDS. SHEETS USED IN THE CONSTRUCTION OF DAMPPANS AND SHEAR WALLS SHALL BE NOT LESS THAN 4x8. MINIMUM SHEET SIZE AT BOUNDARIES AND CHANGES IN FRAMING SHALL BE 2x4, UNLESS BLOCKED. FRAMING MEMBERS SHALL HAVE BLOCKING AT ALL PANEL EDGES IN SHEAR WALLS.
6. GLUE FOR GLUED FLOOR CONSTRUCTION: APA PERFORMANCE SPECIFIC, AFQ-01.
7. HANGERS AND CONNECTIONS: SIMPSON STRONG-TIE (AS NOTED ON DRAWINGS), UNFED STEEL PRODUCTS OF APPROVED QUALITY.
8. HANGERS AND ALL OTHER HARDWARE IN CONTACT WITH PRESSURE TREATED LUMBER SHALL BE COMPATIBLE WITH PRESSURE TREATING CHEMICAL. CONTRACTOR TO VERIFY COMPATIBILITY PRIOR TO CONSTRUCTION.
9. FASTENERS/NAILING: AS NOTED DRAWINGS, IF NOT SHOWN ON DRAWINGS, NAILING OF FRAMING COMPONENTS SHALL CONFORM TO CBC TABLE 2304.9.1 AS A MINIMUM.
10. ALL MULTIPLE TRIMMERS, MULTIPLE STUDS, OR POSTS SHALL BE STACKED IN ALL WALL FRAMING CONNECTED WITH POSITIVE CONNECTIONS. SOLID BLOCKING SIMILAR IN SIZE TO FRAMING ABOVE SHALL BE PROVIDED AT ALL FLOORS ALL THE WAY DOWN THE FOUNDATION.
11. DO NOT NOTCH BEAMS, JOISTS, OR TRUSSES WITHOUT FIRST CONTACTING ENGINEER OF RECORD. DRILLING AND NOTCHING SHALL BE IN ACCORDANCE WITH CALIFORNIA RESIDENTIAL CODE R602.6 (1).  
1. NOTCHING: ANY STUD IN AN EXTERIOR WALL OR BEARING PARTITION MAY BE CUT OR NOTCHED TO A DEPTH NOT EXCEEDING 25% OF ITS WIDTH. STUDS IN NONBEARING PARTITIONS MAY BE NOTCHED TO A DEPTH NOT TO EXCEED 40% OF A SINGLE STUD WIDTH.  
2. DRILLING: ANY STUD MAY BE BORED OR DRILLED, PROVIDED THAT THE DIAMETER OF THE RESULTING HOLE IS NO MORE THAN 60% OF THE STUD WIDTH. THE EDGE OF THE HOLE IS NO MORE THAN 5" TO THE EDGE OF THE STUD, AND THE HOLE IS NOT LOCATED IN THE SAME SECTION AS A CUT OR NOTCH. STUDS LOCATED IN EXTERIOR WALLS OR BEARING PARTITIONS DRILLED OVER 40% AND UP TO 60% SHALL ALSO BE DOUBLED WITH NO MORE THAN TWO SUCCESSIVE DOUBLED STUDS BORED.
12. CONNECT DOUBLE STUDS, DOUBLE JOISTS, OR ANY OTHER MULTIPLE PIECE MEMBER WITH MINIMUM (2) ROWS 16d AT 12" O.C. UNLESS OTHERWISE NOTED.
13. USE (2) CONTINUOUS KING STUDS EACH SIDE OF OPENINGS WHERE STUD HEIGHT EXCEEDS 10'.
14. DO NOT BREAK CONTINUOUS KING STUDS BY SPANNING HEADERS OVER MULTIPLE OPENINGS.
15. ALL EXTERIOR WALLS TO BE CONSIDERED SHEARWALLS AND SHALL BE NAILED WITH 8d AT 6" AND 12" UNLESS OTHERWISE NOTED.
16. FLOOR JOISTS SHALL BE BLOCKED SOLID AT ALL SUPPORT LINES (CONNECT BLOCKING TO WALL/BREAM BELOW WITH A34 AT 48" O.C. U.N.O.) BENEATH ALL INTERIOR BEARING WALLS.
17. ALL BEAMS AND HEADERS TO HAVE A SINGLE 2x TRIMMER AND KING STUD THE SAME WIDTH OF BEAM MINIMUM UNLESS NOTED OTHERWISE.
18. Fire blocking required for combustible construction in the following concealed spaces of stud walls and partitions spaces, including furred spaces as follows: (CRC R302.1.1)  
1. Vertically at the ceiling and floor levels.  
2. Horizontally at intervals not exceeding 10-ft.  
3. Interconnections between concealed vertical stud walls and concealed horizontal spaces created by floor systems, soffits, drop ceilings, cove ceilings, and similar locations.  
4. Between stair stringers at top and bottom of run.  
5. Around vent openings, pipes, ducts, chimneys, fireplaces, similar openings that afford passage for fire.

#### CONCRETE NOTES

1. REINFORCED CONCRETE WORK, MIXING, PLACEMENT AND QUALITY SHALL CONFORM TO APPLICABLE REQUIREMENTS OF THE CBC AND ACI STANDARD 318.
  2. NO PIPES OR DUCTS SHALL BE PLACED IN CONCRETE WALLS OR SLABS UNLESS SPECIFICALLY DETAILED.
  3. EXTERIOR SLABS ON GRADE SHALL CONTAIN NOT MORE THAN 6% ENTRAINED AIR.
  4. FOLLOW RECOMMENDED PRACTICES FOR HOT AND COLD WEATHER CONCRETING BY OBSERVING ACI 305 AND ACI 308 GUIDELINES.
  5. PROVIDE STANDARD CRACK CONTROL JOINTS IN ALL SLABS ON GRADE AT 2 TO 3 TIMES THE SLAB THICKNESS (n) IN FEET O.C. EACH WAY (MAX), @ 4' SLAB = 8 FEET TO 12 FEET JOINT SPACING) MAXIMUM JOINT SPACING NOT TO EXCEED 15'-0". JOINTS SHALL BE SAW CUT SUCH THAT THE ENCLOSED AREA DOES NOT EXCEED 150 SQUARE FEET. JOINT DEPTH SHALL NOT EXCEED ONE FOURTH OF SLAB DEPTH.
  6. TOP OF CONCRETE SLABS SHALL BE MINIMUM 6' ABOVE FINISHED GRADE.
  7. MINIMUM 28 DAY COMPRESSIVE STRENGTH SHALL BE AS FOLLOWS:  
-FOOTINGS, GRADE BEAMS, AND WALLS f<sub>c</sub> = 4,000psi  
-STRUCTURAL BEAMS, COLUMNS, AND WALLS f<sub>c</sub> = 4,000psi  
-STRUCTURAL SLABS ( 'PAN DECK' ) f<sub>c</sub> = 3,000psi  
-SLAB-ON-GRADE f<sub>c</sub> = 2,500psi
- CONCRETE MIXES SHALL BE DESIGNED BY AN APPROVED TESTING LABORATORY CONCRETE PROPORTION SHALL COMPLY WITH CHAPTER 5 OF THE ACI-318.
- UNLESS OTHERWISE APPROVED CONCRETE SLUMP SHALL NOT EXCEED 4 INCHES.
- FLYASH SHALL NOT BE USED
- AGGREGATES: NATURAL SAND AND ROCK AGGREGATES SHALL CONFORM TO ASTM 33.
- ALL REINFORCING STEEL SHALL HAVE A LAP SPLICE PER MINIMUM REQUIREMENT OF ACI 318, UNLESS OTHERWISE NOTED.
- SPLICES OF HORIZONTAL REINFORCING IN WALLS SHALL BE STAGGERED.
8. MINIMUM CONCRETE COVERAGE - THE FOLLOWING MINIMUM CLEAR DISTANCES BETWEEN ANY REINFORCING STEEL AND THE FACE OF CONCRETE SHALL BE MAINTAINED UNLESS OTHERWISE INDICATED.  
-SLAB ON EARTH 1 INCH FROM TOP OF SLAB  
-CURBS OR STEM WALLS CENTER OF WALL  
-WALLS ABOVE GRADE-EXTERIOR FACE 1 INCHES FOR #5 & SMALLER  
2 INCHES FOR #6 AND LARGER  
-WALL-INTERIOR FACE 1 INCH  
-COLUMNS, FLASERS 1 INCHES  
-CONCRETE BELOW GRADE PLACED AGAINST EARTH 3 INCHES
  9. REINFORCING STEEL IN STRUCTURAL SLABS, WALLS AND FOOTINGS SHALL CONFORM TO ASTM A-615, GRADE 60.
  10. ANCHOR BOLTS, DOWELS, INSERTS, ETC. SHALL BE SECURELY TIED IN PLACE PRIOR TO THE PLACING OF CONCRETE OR GROUT.
  11. CEMENT SHALL BE PORTLAND CEMENT CONFORMING TO ASTM C-150
  12. WELDING OF REINFORCING STEEL SHALL CONFORM TO AWS D1.4 USING HYDROGEN ELECTRODES. WELDED REINFORCING STEEL SHALL CONFORM TO ASTM 706, GRADE 60 WELDING SHALL BE E70XX UNLESS OTHERWISE NOTED.
  13. WHERE DRILLED ANCHORS ARE USED, COORDINATE POSITIONING WITH REINFORCING STEEL.
  14. ALL CONCRETE REINFORCEMENT MUST BE SECURED AND SUPPORTED PRIOR TO CONCRETE PLACEMENT.
  15. MINIMUM SUPPORT WITH 2' x 2' x 2' CONCRETE 'DOBIES' WITH WIRE, OR EQUAL (SUBJECT TO APPROVAL ENGINEER OF RECORD.) MINIMUM PLACEMENT AT EVERY OTHER REINFORCING STEEL CROSSING.

#### SOIL DESIGN PARAMETERS

1. SOIL DESIGN PARAMETERS BASED ON VALUES PROVIDED IN 2022 CALIFORNIA BUILDING CODE, CHAPTER 18, TABLE 1806.2 PRESUMPTIVE LOAD-BEARING VALUES, TYPE S SOIL.
2. ALLOWABLE END BEARING PRESSURE 1500psf
3. ALLOWABLE LATERAL BEARING PRESSURE 100psf
4. ACTUAL ALLOWABLE SOIL PARAMETERS MUST BE VERIFIED ON SITE.
5. A GEOTECHNICAL ENGINEER OR FIRM REPRESENTATIVE IS RECOMMENDED (NOT REQUIRED) TO BE AVAILABLE AT THE TIME OF THE FOUNDATION INSTALLATION TO VERIFY THE SOIL DESIGN PARAMETERS AND TO PROVIDE ASSISTANCE IF ANY PROBLEMS ARISE IN FOUNDATION INSTALLATION.
6. ENCOUNTERING SOIL FORMATIONS THAT WILL REQUIRE SPECIAL DESIGN CONSIDERATIONS OR EXCAVATION PROCEDURES MAY OCCUR. FOUNDATIONS WILL NEED TO BE ANALYZED ACCORDING TO THE SOIL CONDITIONS THAT EXIST. IF ANY DISCREPANCIES OR INCONSISTENCIES ARISE, NOTIFY THE ENGINEER OF SUCH DISCREPANCIES. FOUNDATIONS WILL THEN BE REVISED ACCORDINGLY. REVISIONS WILL BE ANALYZED PER RECOMMENDATIONS DIRECTED BY A REGISTERED ENGINEER.
7. ALL EXCAVATIONS MUST BE FREE OF WATER, LOOSE SOIL, AND DEBRIS PRIOR TO FOUNDATION INSTALLATION AND CONCRETE PLACEMENT.

#### CONSTRUCTION WASTE MANAGEMENT PLAN

1. RECYCLE OR SALVAGE FOR FUTURE USE A MINIMUM OF 65% OF THE NON HAZARDOUS CONSTRUCTION AND DEMOLITION WASTE.
  2. THE FOLLOWING WASTE MANAGEMENT PLAN SHALL BE FOLLOWED BY THE CONTRACTOR AND UPDATED BY THE CONTRACTOR AS REQUIRED.
- | WASTE MATERIAL                               | DISPOSAL METHOD        | DISPOSAL LOCATION                 |
|--|------------------------|-----------------------------------|
| CLEAN WOOD SCRAP (NO PT WOOD, NO GLUED WOOD) | SEPARATION AND RECYCLE | WASTE MANAGEMENT RECYCLE FACILITY |
| CARDBOARD (PACKAGING ETC.)                   | SEPARATION AND RECYCLE | WASTE MANAGEMENT RECYCLE FACILITY |
| PLASTICS (PACKAGING, PIPE OFFCUTS ETC.)      | SEPARATION AND RECYCLE | WASTE MANAGEMENT RECYCLE FACILITY |
| METALS (PACKAGING, PIPE OFFCUTS ETC.)        | SEPARATION AND RECYCLE | WASTE MANAGEMENT RECYCLE FACILITY |
| CONCRETE (CLEAN, NO REBAR)                   | SEPARATION AND RECYCLE | WASTE MANAGEMENT RECYCLE FACILITY |
3. THE PERCENTAGE OF WASTE MATERIAL DIVERTED FROM LANDFILL SHALL BE CALCULATED BY VOLUME (CU FT).
  4. THE CONTRACTOR SHALL EMPLOY COST EFFICIENT CONSTRUCTION PRACTICES TO REDUCE THE GENERATION OF WASTE DURING THE CONSTRUCTION PROCESS.
  5. CONTRACTOR TO PROVIDE DOCUMENTATION OF WASTE DIVERSION WEIGHT TO ENFORCING AGENCY AT COMPLETION OF PROJECT.

#### WILDLAND/URBAN INTERFACE

CHAPTER 7A OF THE 2022 CBC - WILDLAND URBAN INTERFACE FIRE RESISTANCE APPLIES TO THIS PROJECT, SEE FIRE RESISTANCE AND FIRE SPRINKLER.

#### FIRE SPRINKLER NOTES

1. RESIDENTIAL FIRE SPRINKLERS ARE NOT REQUIRED FOR THIS PROJECT

#### FIRE RESISTANCE NOTES

1. EXTERIOR WINDOWS, WINDOW WALLS, GLAZED DOORS AND GLAZED OPENINGS WITHIN EXTERIOR DOORS SHALL BE INSULATING GLASS UNITS WITH A MINIMUM OF ONE TEMPERED PANE OR GLASS BLOCK UNITS OR HAVE A FIRE RESISTIVE RATING OF NOT LESS THAN 20 MINUTES OR BE TESTED TO MEET THE PERFORMANCE REQUIREMENTS OF SFM STANDARD 12-7A-2 PER CBC 708A.2.1
2. EXTERIOR DOOR ASSEMBLIES SHALL CONFORM TO THE PERFORMANCE REQUIREMENTS FOR STANDARD SFM 12-7A-1 OR THE EXTERIOR SURFACE OR CLADDING SHALL BE OF NONCOMBUSTIBLE OR IGNITION RESISTANT MATERIAL NOT LESS THAN 1 3/8" THICK WITH RAISED PANEL THICKNESS OF NOT LESS THAN 1 1/4" THICK EXCEPT FOR THE EXTERIOR PERIMETER OF THE RAISED PANEL THAT MAY TAPER TO A TONGUE NOT LESS THAN 3/8" THICK OR SHALL HAVE A FIRE RESISTANCE RATING OF NOT LESS THAN 20 MINUTES PER CBC 708A.
3. ROOF CONSTRUCTION MUST COMPLY WITH CBC 706A VALLEY FLASHING MUST COMPLY WITH CBC SECTION R327.5.3. ROOF GUTTERS SHALL BE PROVIDED WITH THE MEANS TO PREVENT THE ACCUMULATION OF LEAVES AND DEBRIS IN THE GUTTER.
4. VENTILATION OPENING FOR ATTIC SPACES AND UNDER FLOOR AREAS SHALL BE COVERED BY A NON COMBUSTIBLE, CORROSION RESISTANT MESH MATERIAL WITH OPENING SIZES A MIN. OF 1/16" AND MAX. 1/8" PER CBC 708A. UNLESS THE ATTIC SPACE IS PROTECTED BY AN APPROVED FIRE SPRINKLER SYSTEM OR UNLESS THE ATTIC VENTS ARE LOCATED MORE THAN 12" FROM THE GROUND, WALKING SURFACE OR DECK OR SIMILAR SURFACE. EAWE VENTS SHALL BE APPROVED TO RESIST THE INTRUSION OF FLAME AND BURNING EMBERS INTO THE ATTIC SPACE.
5. EXTERIOR WALL COVERINGS SHALL BE AN APPROVED NON COMBUSTIBLE OR IGNITION RESISTANT MATERIAL PER CBC 707A. THE EXTENDED ROOF DECK ON THE UNDERSIDE OF ROOF EAVES SOFFITS, EXTERIOR PORCH CEILING, THE UNDERSIDE OF FLOOR PROJECTIONS OVER EXTERIOR WALLS AND THE UNDERSIDE OF ELEVATED OR OVERHANGING FLOORS SHALL BE OF A NON COMBUSTIBLE MATERIAL OR AN IGNITION RESISTANT MATERIAL.
6. DECKING SURFACES OF DECKS, PORCHES, BALCONIES AND STAIRS LOCATED WITHIN 10' OF THE BUILDING SHALL COMPLY WITH CBC 709A AND BE OF AN IGNITION RESISTANT MATERIAL. EXTERIOR FIRE RETARDANT TREATED WOOD OR A NON COMBUSTIBLE MATERIAL.

#### GENERAL NOTES

1. LAND & STRUCTURE RESERVES THE RIGHT TO PERFORM OBSERVATION VISITS TO THE SITE AT ANY TIME. OBSERVATIONS ARE PERFORMED SOLELY FOR THE PURPOSE OF DETERMINING IF THE CONTRACTOR UNDERSTANDS THE DESIGN INTENT CONVEYED IN THE PLANS. OBSERVATIONS DO NOT GUARANTEE CONTRACTORS PERFORMANCE AND ARE NOT TO BE CONSTRUED AS SUPERVISION OF THE PROJECT.
2. ALL WORK SHALL COMPLY WITH:  
-CALIFORNIA RESIDENTIAL CODE CRC 2022 EDITION  
-CALIFORNIA BUILDING CODE CBC 2022 EDITION  
-CALIFORNIA PLUMBING CODE CPC 2022 EDITION  
-CALIFORNIA MECHANICAL CODE CMC 2022 EDITION  
-CALIFORNIA ELECTRICAL CODE CEC 2022 EDITION  
-CALIFORNIA FIRE CODE 2022 EDITION  
-CALIFORNIA ENERGY CODE CEC 2022 EDITION  
-CALIFORNIA GREEN BUILDING CODE 2022 EDITION  
-AND ALL OTHER APPLICABLE STATE AND COUNTY CODES AND ORDINANCES.
3. ALL INSPECTIONS REQUIRED BY THE BUILDING CODE, LOCAL BUILDING DEPARTMENT, OR BY THESE PLANS SHALL BE PROVIDED BY AN INDEPENDENT INSPECTION COMPANY OR THE BUILDING DEPARTMENT. SITE VISITS BY THE ENGINEER OF RECORD (E.O.R.) DO NOT CONSTITUTE AN INSPECTION.
4. IN THE EVENT THAT CERTAIN EXISTING DIMENSIONS AND/OR CONDITIONS ARE FOUND TO BE DIFFERENT FROM THOSE SHOWN ON THE PLANS AND DETAILS, THE ENGINEER SHALL BE IMMEDIATELY NOTIFIED SO THAT THE PROPER REVISIONS CAN BE MADE IF NECESSARY. THE CONTRACTOR SHALL BE HELD RESPONSIBLE FOR THE RESULTS OF ANY ERRORS, DISCREPANCIES, OR OMISSIONS WHICH THE CONTRACTOR FAILED TO NOTIFY LAND & STRUCTURE OF BEFORE CONSTRUCTION AND/OR FABRICATION OF THE WORK.
5. THE CONTRACTOR SHALL BE RESPONSIBLE FOR VERIFICATION OF ALL DIMENSIONS, CONDITIONS AND ELEVATIONS WITH DRAWINGS PRIOR TO START OF CONSTRUCTION. THE CONTRACTOR SHALL INFORM THE ENGINEER IN WRITING OF ANY DISCREPANCIES OR OMISSIONS NOTED ON THE DRAWINGS. ANY SUCH DISCREPANCY, OMISSION, OR VARIATION NOT REPORTED BEFORE THE START OF CONSTRUCTION SHALL BE THE RESPONSIBILITY OF THE CONTRACTOR.
6. THE DETAILS SHOWN ON THE DRAWINGS ARE TYPICAL. SIMILAR DETAILS APPLY TO SIMILAR CONDITIONS. NO DEVIATIONS FROM STRUCTURAL DETAILS SHALL BE MADE WITHOUT THE PRIOR WRITTEN APPROVAL OF LAND & STRUCTURE.
7. THESE DRAWINGS REPRESENT THE FINAL STRUCTURE AND DO NOT INDICATE THE METHOD OF CONSTRUCTION. THE CONTRACTOR SHALL BE SOLELY RESPONSIBLE FOR THE CONSTRUCTION MEANS, METHODS, TECHNIQUES, SEQUENCES AND PROCEDURES. IT SHALL BE THE CONTRACTORS RESPONSIBILITY TO DESIGN AND PROVIDE ADEQUATE SHORING, BRACING, FORM-WORK, ETC. AS REQUIRED FOR THE PROTECTION OF LIFE AND PROPERTY DURING CONSTRUCTION. CONSTRUCTION MATERIALS SHALL BE UNIFORMLY SPREAD OUT SUCH THAT THE DESIGN LIVE LOAD PER SQUARE FOOT IS NOT EXCEEDED. SHOULD AN UNFINISHED STRUCTURE BE SUBJECTED TO EXCESSIVE LOADS, LAND & STRUCTURE SHOULD BE CONSULTED FOR AN INTERIM DESIGN, OR IF NOT, WILL ASSUME NO LIABILITY.
8. ALL HARDWARE AND FRAMING MEMBERS SPECIFIED IN THE PLANS ARE MINIMUMS AND LARGER MEMBERS OF EQUAL OR BETTER GRADE MAY BE SUBSTITUTED.
9. THESE PLANS HAVE BEEN PREPARED USING STANDARDS OF CARE AND COMPLETENESS NORMALLY EXERCISED UNDER SIMILAR CIRCUMSTANCES BY REPUTABLE ENGINEERS IN THIS OR SIMILAR LOCALITIES. THEY NECESSARILY ASSUME THAT THE WORK DEPICTED WILL BE PERFORMED BY AN EXPERIENCED CONTRACTOR AND/OR WORKMEN WHO HAVE A WORKING KNOWLEDGE OF THE APPLICABLE CODE STANDARDS AND REQUIREMENTS AND OF INDUSTRY STANDARD GOOD PRACTICE. AS NOT EVERY CONDITION OR ELEMENT IS (OR CAN BE) EXPLICITLY SHOWN ON THESE PLANS, IT IS UNDERSTOOD THAT THE CONTRACTOR WILL USE INDUSTRY ACCEPTED STANDARD GOOD PRACTICE FOR ALL MISCELLANEOUS WORK NOT EXPLICITLY SHOWN.
10. ESTABLISH AND VERIFY ALL OPENINGS AND INSERTS FOR MECHANICAL, ELECTRICAL, AND PLUMBING WITH APPROPRIATE TRADES, DRAWINGS, AND SUBCONTRACTORS PRIOR TO CONSTRUCTION.
11. THE ENGINEER PREPARING THESE PLANS WILL NOT BE RESPONSIBLE FOR, OR LIABLE FOR, UNAUTHORIZED CHANGES TO OR USES OF THESE PLANS. ALL CHANGES TO THE PLANS MUST BE IN WRITING AND MUST BE APPROVED BY THE ENGINEER OF RECORD.

#### ROOF FRAMING NOTES

1. ROOF COVERING SHALL BE STANDING SEAM METAL ROOF PANELS OVER MIN 30# FELT AND 2x6 T&G SELECT DEK.
2. SELECT DEK SHALL BE ATTACHED TO TRUSSES WITH (2)-#10x3-1/2" WOOD SCREWS-TYP.

REVISIONS:

rev	date	description

OWNER INFORMATION:  
T.H.C.S.D.  
P.O.Box 649  
Twain Harte CA 95383  
Tom Trott G.M.  
(209) 586-3172

SITE INFORMATION:  
Meadow Drive  
Twain Harte CA 95383  
APN# 049-132-019

PROJECT INFORMATION:  
A Pavilion Plan for:  
**Twain Harte Comm. Serv. Dist.**  
**Meadow Drive**  
**Twain Harte CA 95383**

ENGINEER OF RECORD:

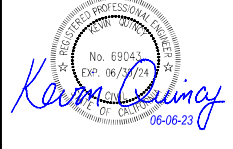

These drawings and specifications are the property of the engineer and shall not be used in any other work except by agreement with the engineer. Written instructions shall have precedence over sealed drawings and shall be verified with the engineer prior to commencement of any work.

ISSUE DATE:	6-6-23
DRAWN BY:	KTQ
CHECKED BY:	ZPG
SCALE:	1/4"=1'-0"
DRAWING:	pavilion
PROJECT NO:	22-07.11
SHEET:	1 OF 5

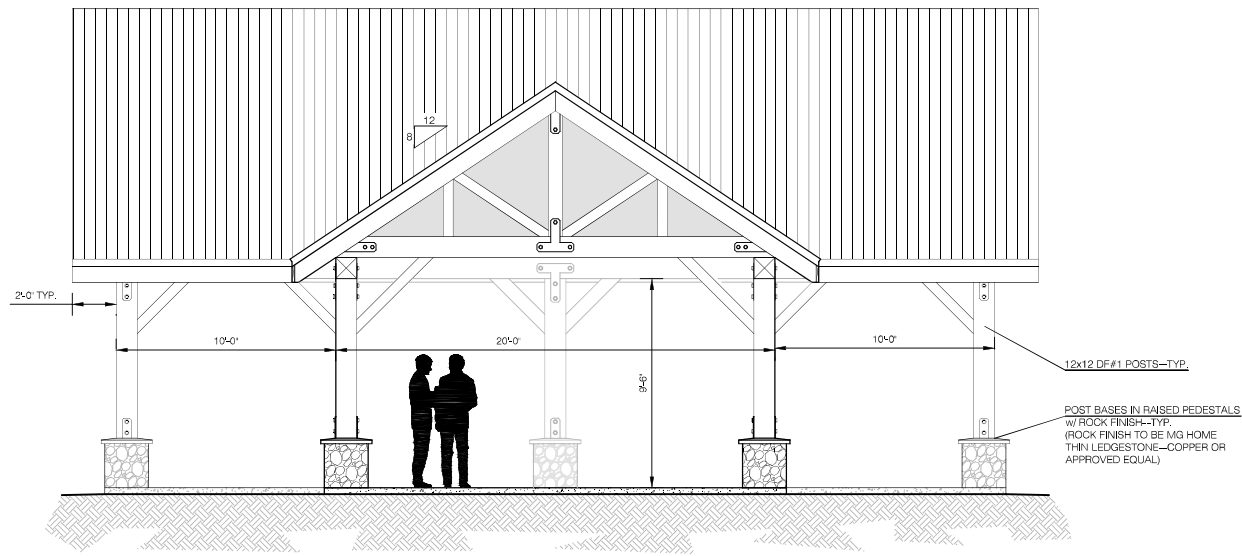

FRONT ELEVATION VIEW

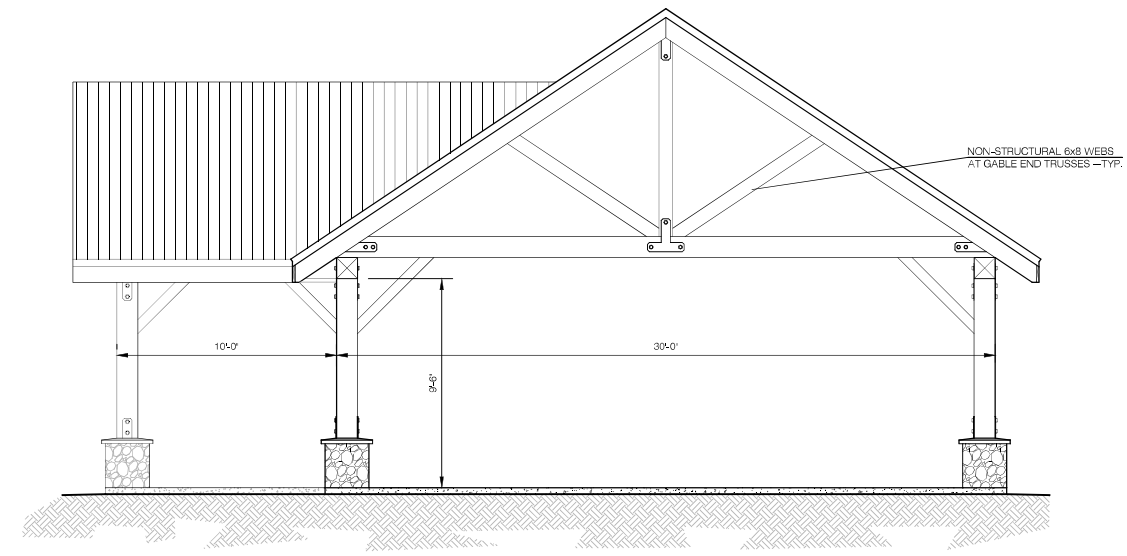

RIGHT ELEVATION VIEW

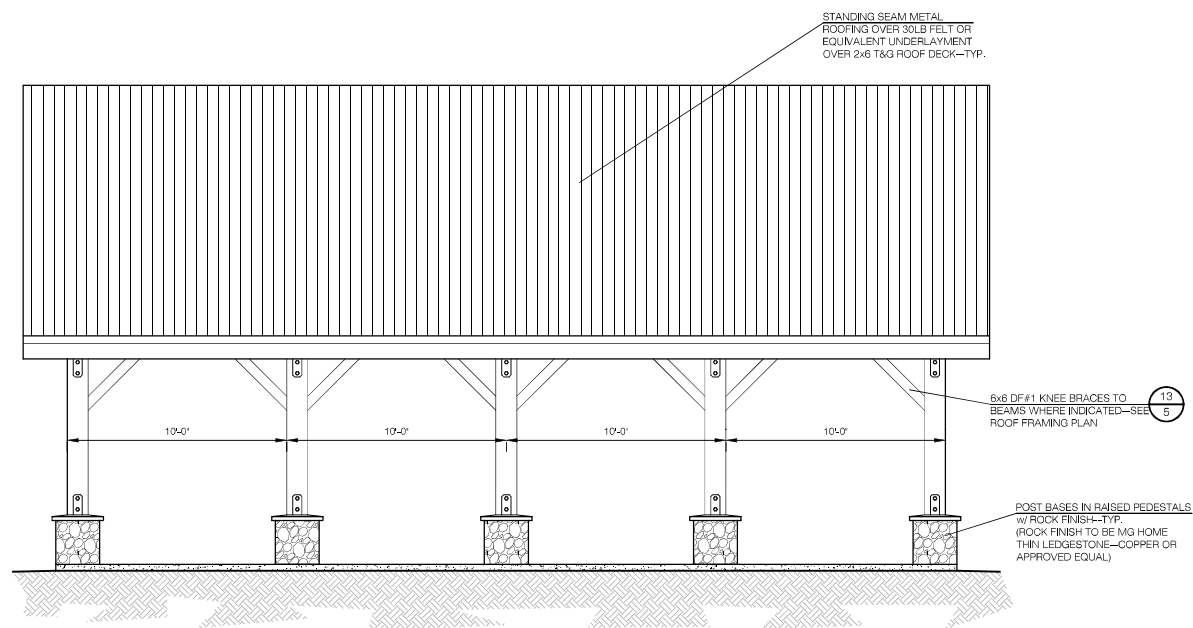

REAR ELEVATION VIEW

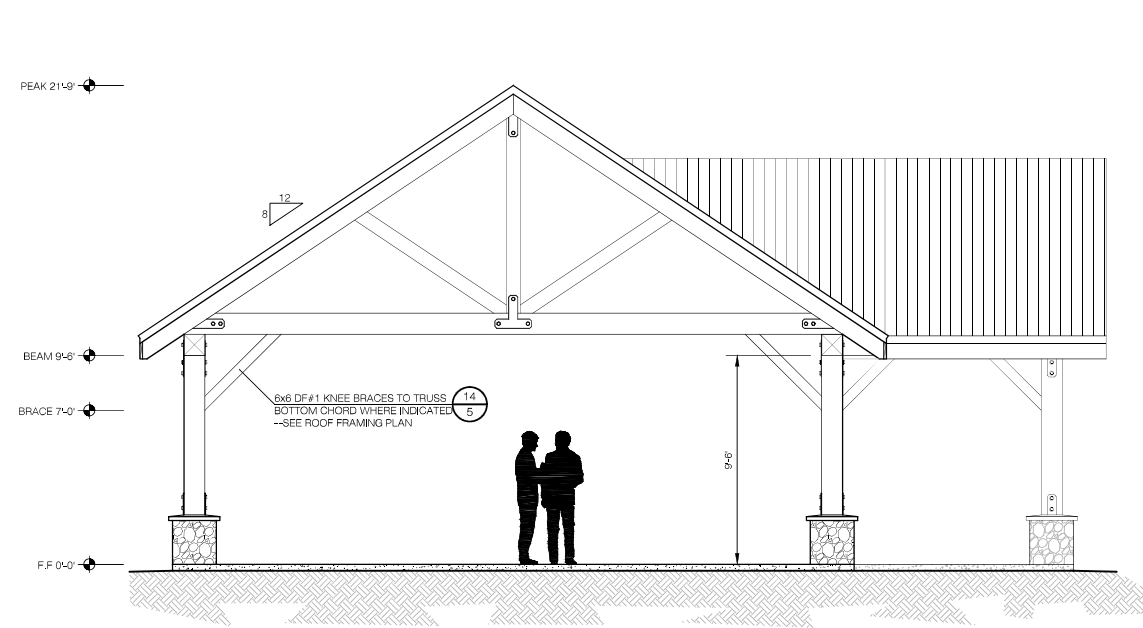

LEFT ELEVATION VIEW

REVISIONS:

rev	date	description

OWNER INFORMATION:  
 T.H.C.S.D.  
 P.O.Box 649  
 Twain Harte CA 95383  
 Tom Trott G.M.  
 (209) 586-3172

SITE INFORMATION:  
 Meadow Drive  
 Twain Harte CA 95383  
 APN# 049-132-019

PROJECT INFORMATION:

A Pavilion Plan for:  
**Twain Harte Comm. Serv. Dist.**  
**Meadow Drive**  
**Twain Harte CA 95383**

ENGINEER OF RECORD:

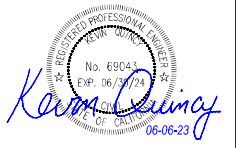

These drawings and specifications are the property of the engineer and shall not be used on any other work except by agreement with the engineer. Written dimensions shall have preference over scaled dimensions and shall be verified on site. Any discrepancies shall be brought to the notice of the engineer prior to commencement of any work.

ISSUE DATE:	6-6-23
DRAWN BY:	KTQ
CHECKED BY:	ZPG
SCALE:	1/4"=1'-0"
DRAWING:	pavilion
PROJECT NO:	22-07.11
SHEET:	2 OF 5



REVISIONS:

rev	date	description

OWNER INFORMATION:  
T.H.C.S.D.  
P.O.Box 649  
Twain Harte CA 95383  
Tom Trott G.M.  
(209) 586-3172

SITE INFORMATION:  
Meadow Drive  
Twain Harte CA 95383  
APN# 049-132-019

PROJECT INFORMATION:  
A Pavilion Plan for:  
**Twain Harte Comm. Serv. Dist.**  
Meadow Drive  
Twain Harte CA 95383

ENGINEER OF RECORD:

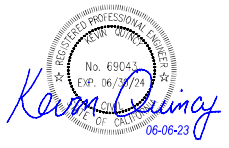

These drawings and specifications are the property of the engineer and shall not be used on any other work except by agreement with the engineer. Written dimensions shall have preference over scaled dimensions and shall be verified on site. Any discrepancies shall be brought to the notice of the engineer prior to commencement of any work.

ISSUE DATE: 6-6-23

DRAWN BY: KTQ

CHECKED BY: ZPG

SCALE: 1/4"=1'-0"

DRAWING: pavilion

PROJECT NO: 22-07.11

SHEET: 3 OF: 5

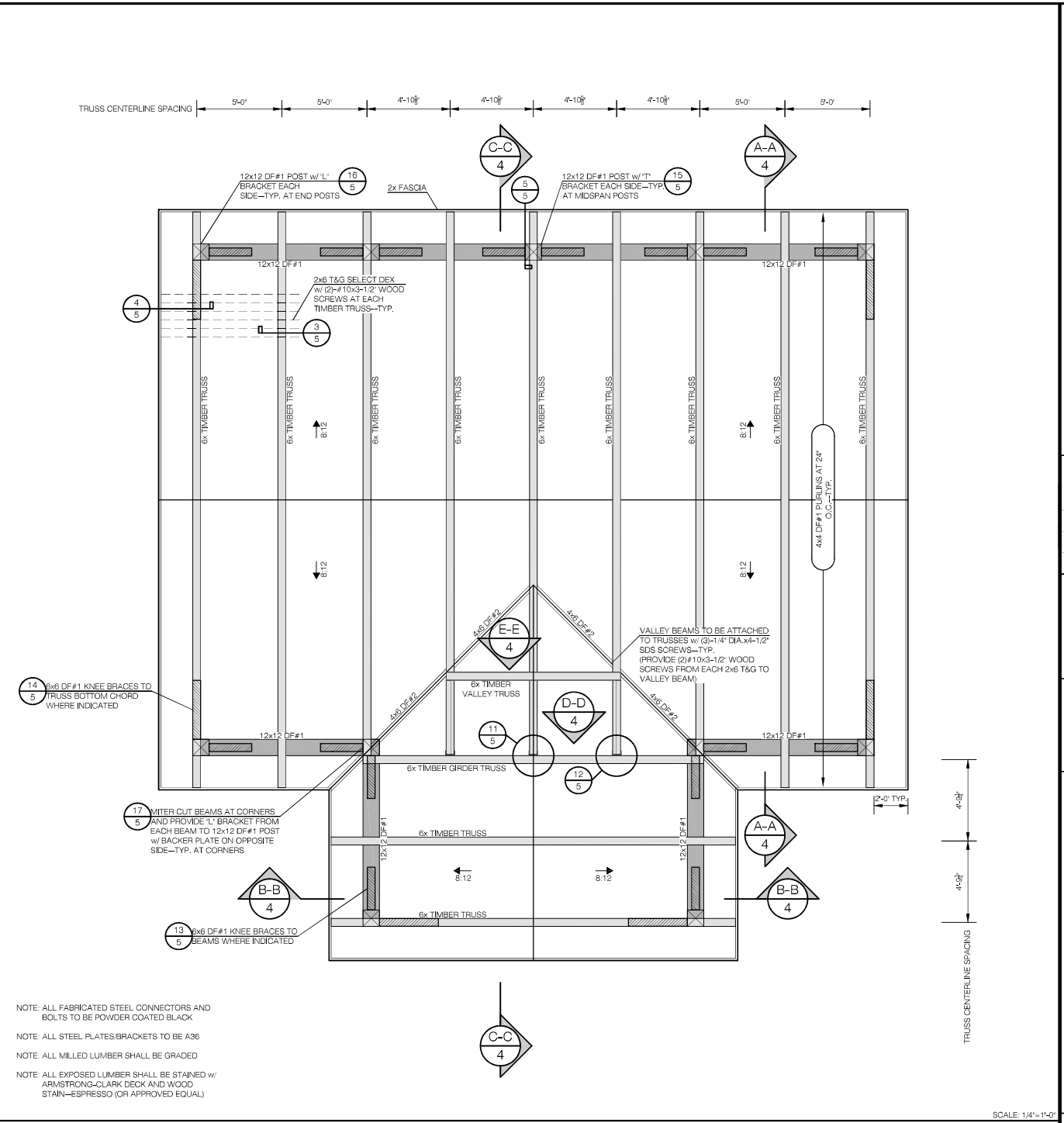

ROOF FRAMING PLAN

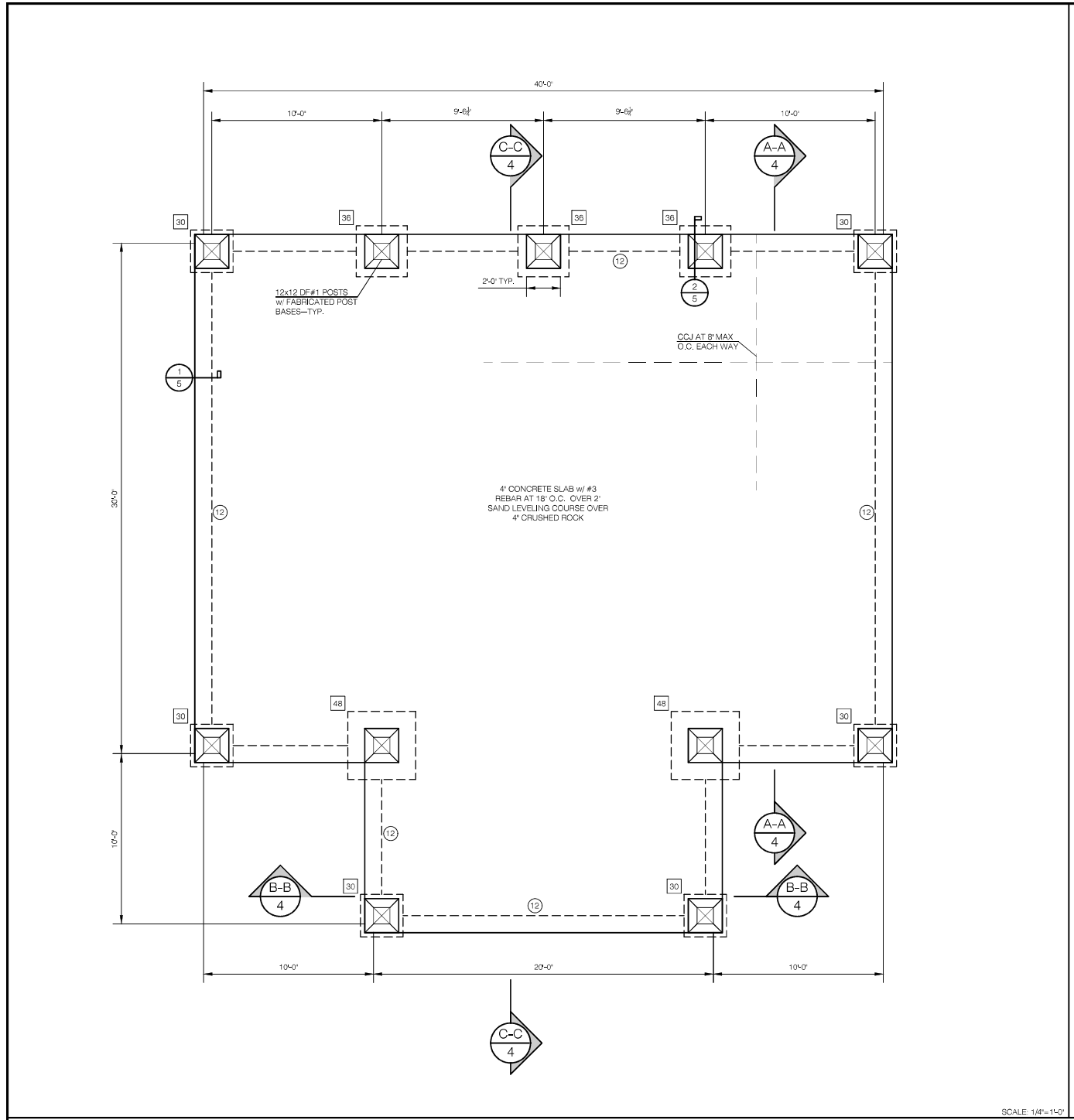

FOUNDATION PLAN

FOOTING SCHEDULE

12	1'-0" WIDE x 1'-0" DEEP THICKENED EDGE WITH #4 CONTINUOUS AT BOTTOM
----	---

PIER PAD SCHEDULE

30	2'-6" SQUARE x 1'-6" DEEP PIER PAD WITH (3)-#4 EACH WAY AT TOP AND BOTTOM
36	3'-0" SQUARE x 1'-6" DEEP PIER PAD WITH (4)-#4 EACH WAY AT TOP AND BOTTOM
48	4'-0" SQUARE x 1'-6" DEEP PIER PAD WITH (5)-#4 EACH WAY AT TOP AND BOTTOM

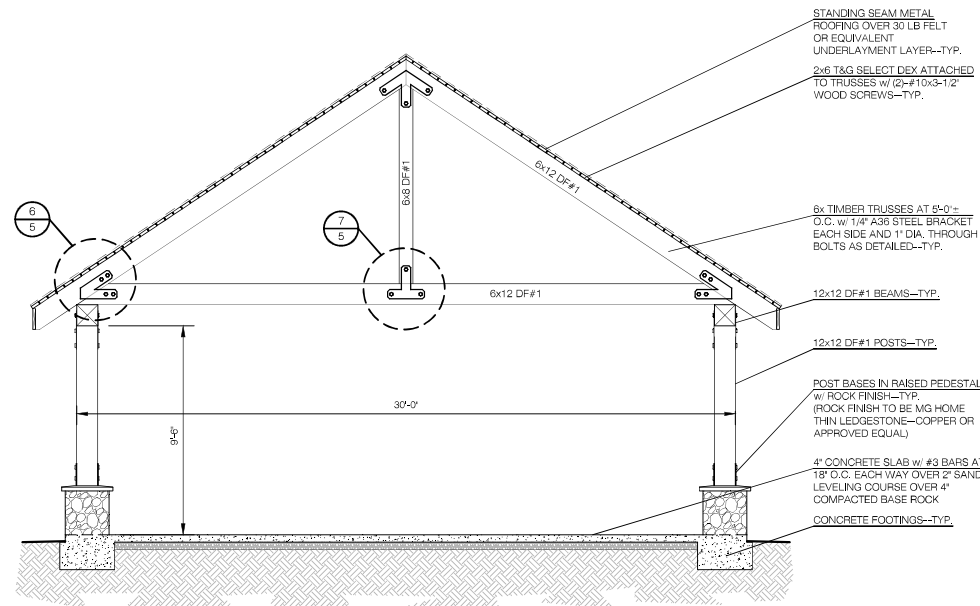

CROSS SECTION A-A

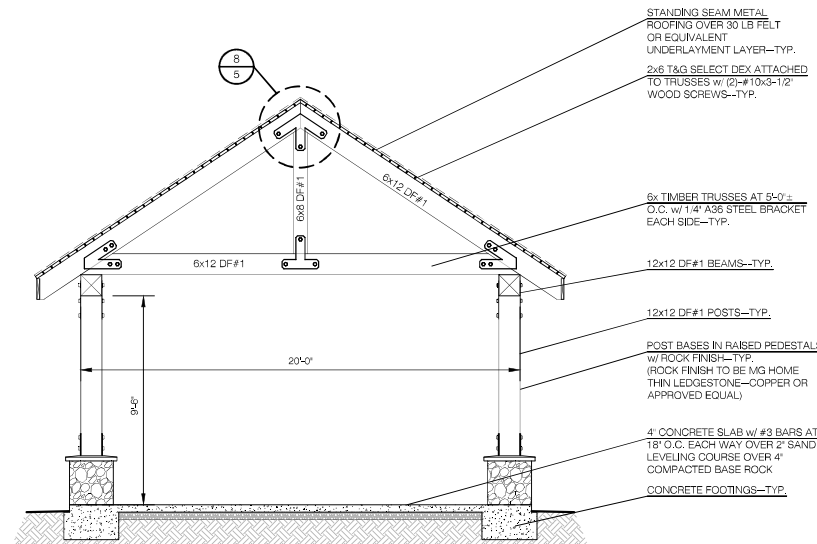

CROSS SECTION B-B

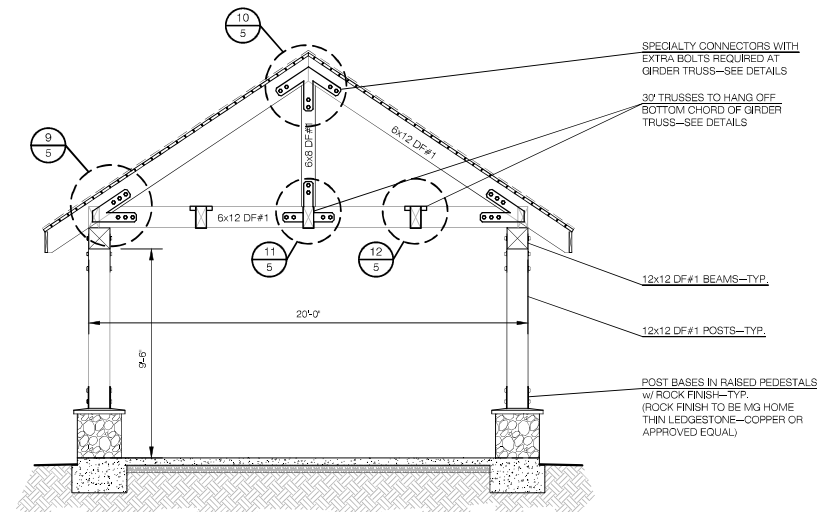

SIDE VIEW WITH TIMBER TRUSSES ATTACHMENT

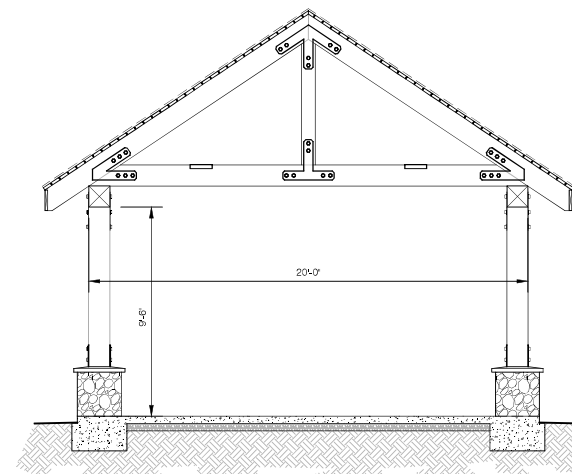

SIDE VIEW OPPOSITE OF TIMBER TRUSSES ATTACHMENT

NOTE: ALL FABRICATED STEEL CONNECTORS AND BOLTS TO BE POWDER COATED BLACK  
 NOTE: ALL STEEL PLATES/BRACKETS TO BE A36  
 NOTE: ALL MILLED LUMBER SHALL BE GRADED  
 NOTE: ALL EXPOSED LUMBER SHALL BE STAINED W/ ARMSTRONG-CLARK DECK AND WOOD STAIN-ESPRESSO (OR APPROVED EQUAL)

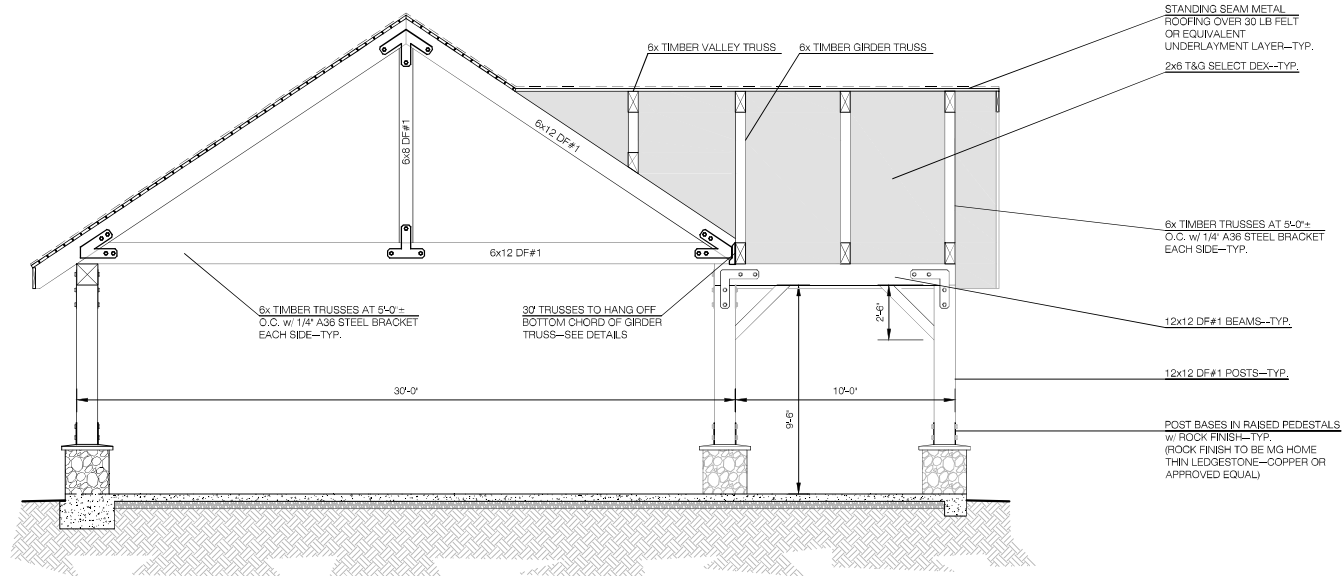

CROSS SECTION C-C

CROSS SECTION D-D (20' GIRDER TRUSS)

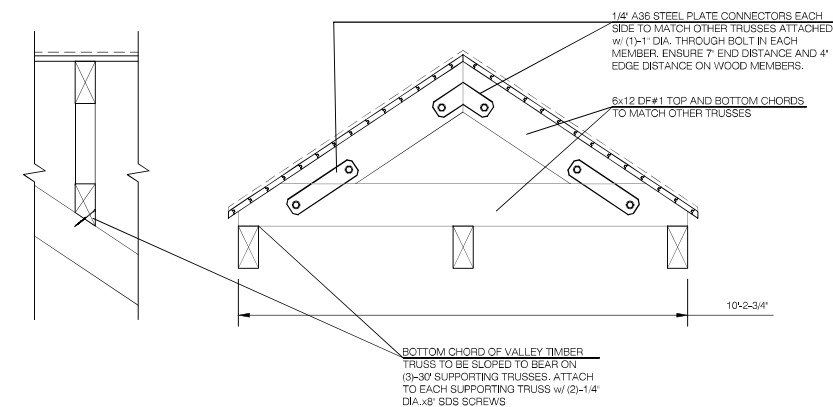

CROSS SECTION E-E (VALLEY TRUSS)

REVISIONS:

rev	date	description

OWNER INFORMATION:  
 T.H.C.S.D.  
 P.O.Box 649  
 Twain Harte CA 95383  
 Tom Trott G.M.  
 (209) 586-3172

SITE INFORMATION:  
 Meadow Drive  
 Twain Harte CA 95383  
 APN# 049-132-019

PROJECT INFORMATION:

A Pavilion Plan for:  
**Twain Harte Comm. Serv. Dist.**  
**Meadow Drive**  
**Twain Harte CA 95383**

ENGINEER OF RECORD:

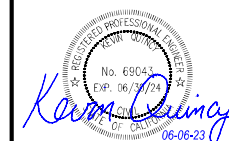

These drawings and specifications are the property of the engineer and shall not be used on any other work except by agreement with the engineer. Written dimensions shall have preference over scaled dimensions and shall be verified on site. Any discrepancies shall be brought to the notice of the engineer prior to commencement of any work.

ISSUE DATE: 6-6-23

DRAWN BY: KTO

CHECKED BY: ZPG

SCALE: 1/4"=1'-0"

DRAWING: pavilion

PROJECT NO: 22-07.11

SHEET: 4 OF: 5

**Land & Structure**  
 SURVEYING | ENGINEERING | DESIGN

105 SOUTH STEWART STREET, SONOMA, CALIFORNIA 94970 T: 209-632-5173 F: 209-532-9220

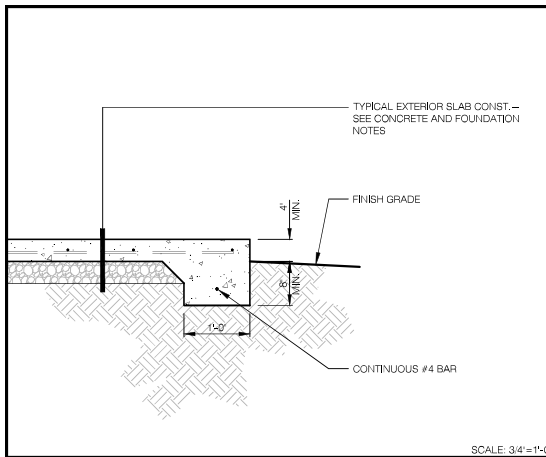

1 TYP. THICKENED SLAB EDGE

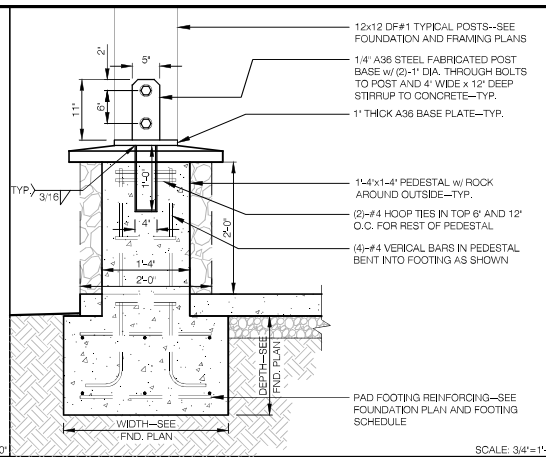

2 PAVILION FOOTING

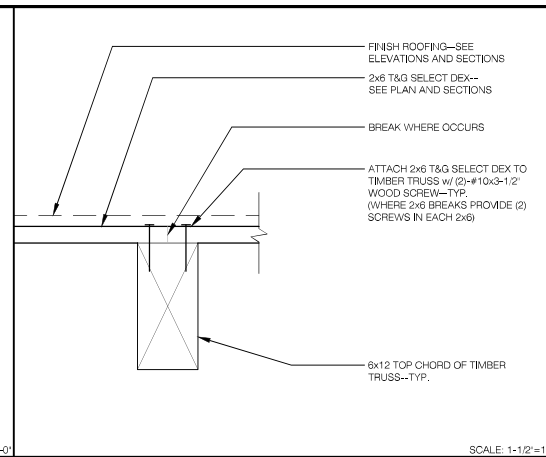

3 T&G ATTACHMENT TO TRUSS

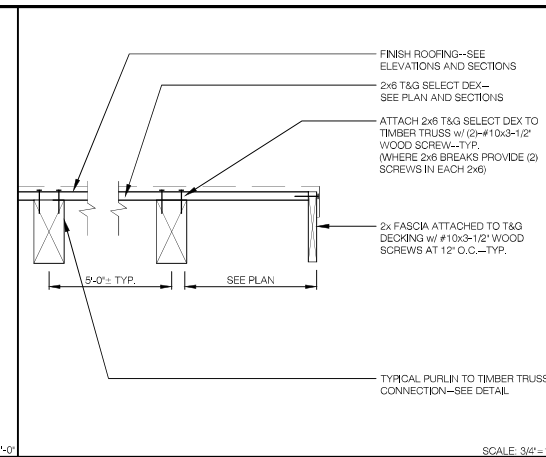

4 GABLE END OVERHANG

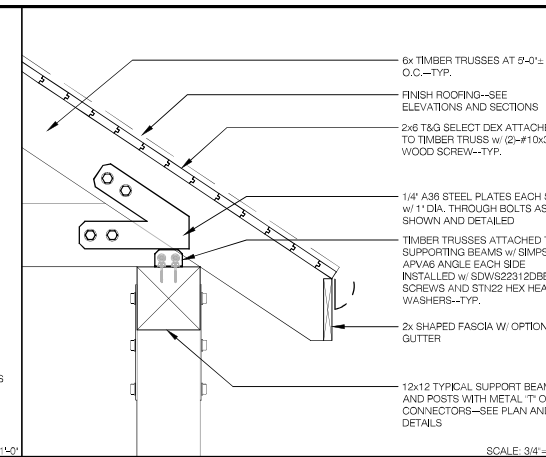

5 TYP. TIMBER TRUSS AT EAVE

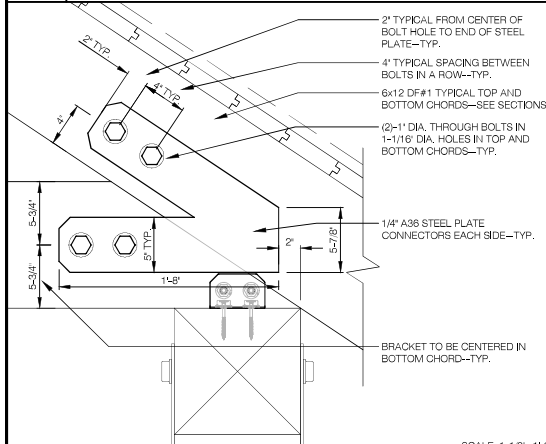

6 TYP. TIMBER TRUSS HEEL CONN.

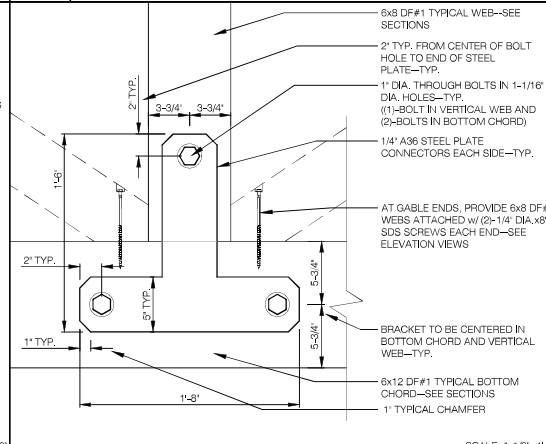

7 TYP. TIMBER TRUSS WEB CONN.

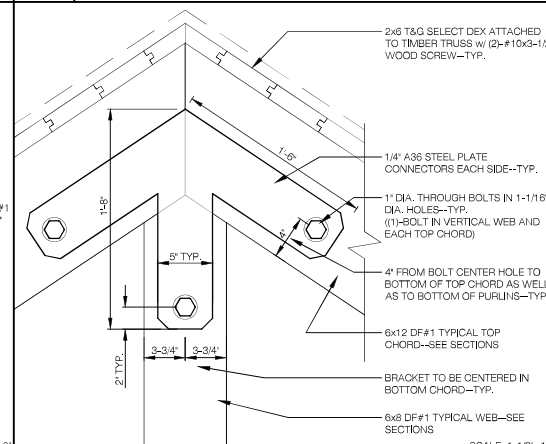

8 TYP. TIMBER TRUSS PEAK CONN.

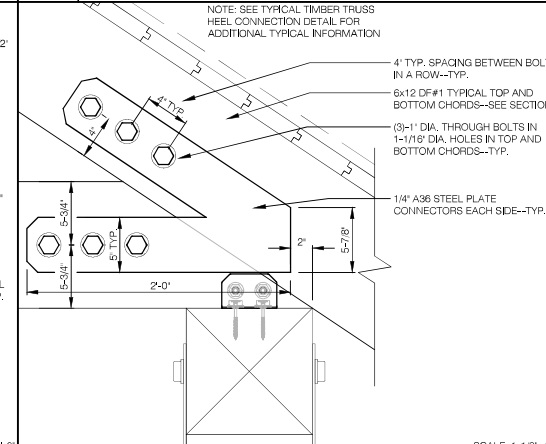

9 GIRDER TRUSS HEEL CONN.

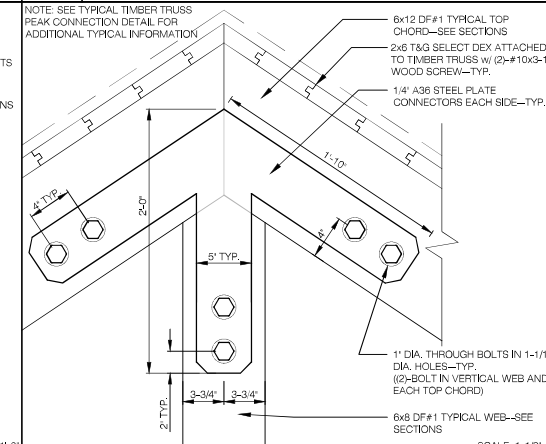

10 GIRDER TRUSS PEAK CONN.

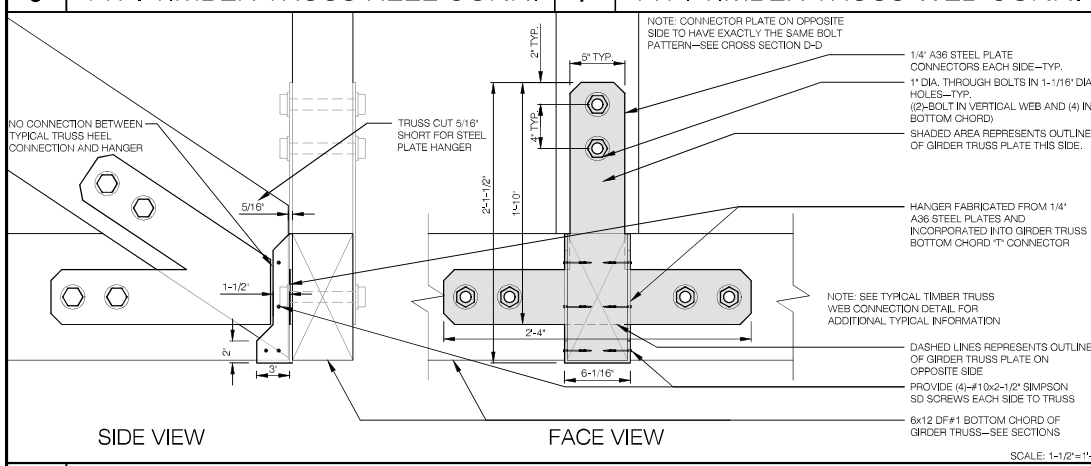

11 GIRDER TRUSS WEB CONN.

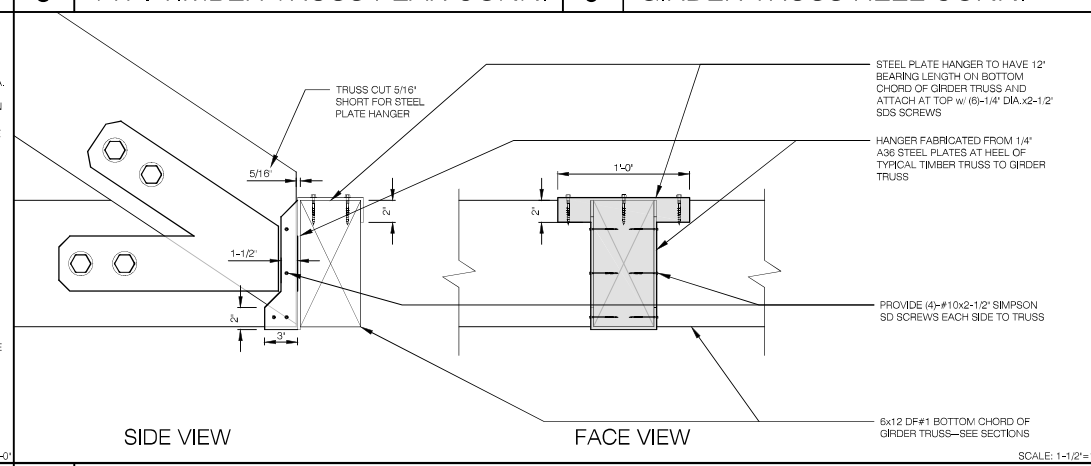

12 TYPICAL TRUSS TO GIRDER TRUSS

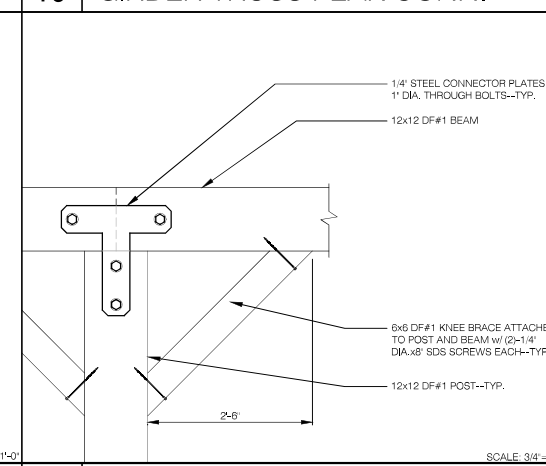

13 KNEE BRACE TO BEAM

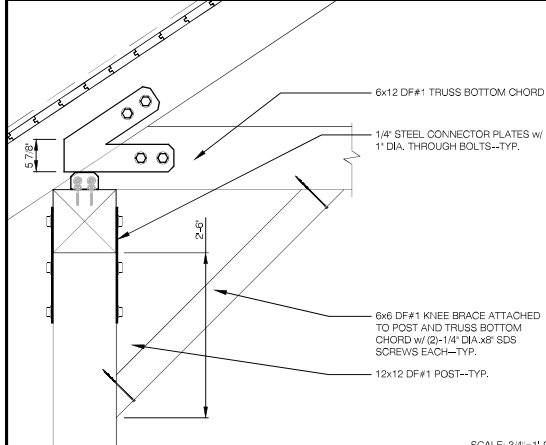

14 KNEE BRACE TO TRUSS

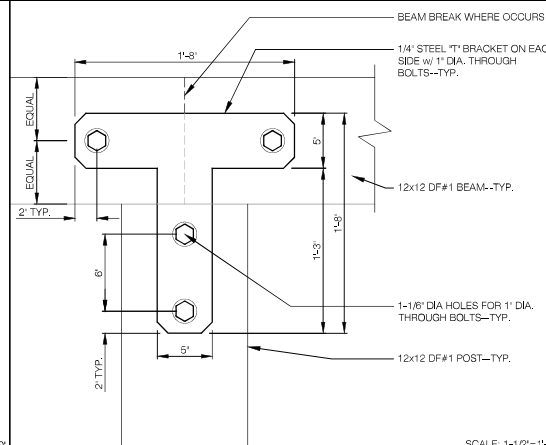

15 POST TO BEAM \"I\" CONNECTOR

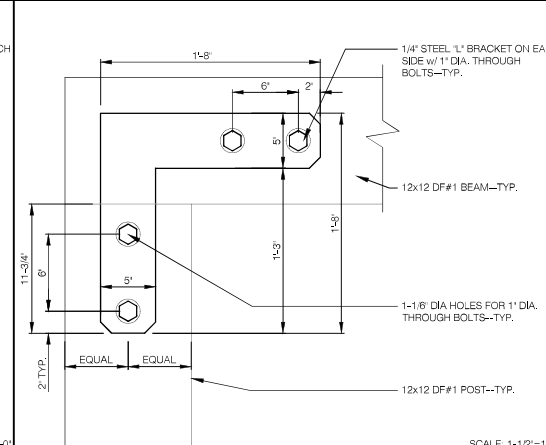

16 POST TO BEAM \"L\" CONNECTOR

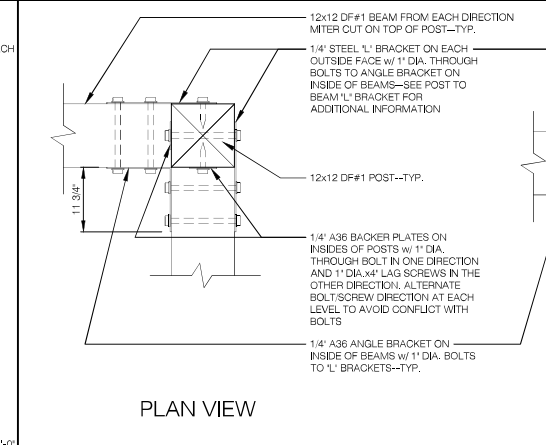

17 POST TO BEAM \"L\" CONNECTOR AT CORNER

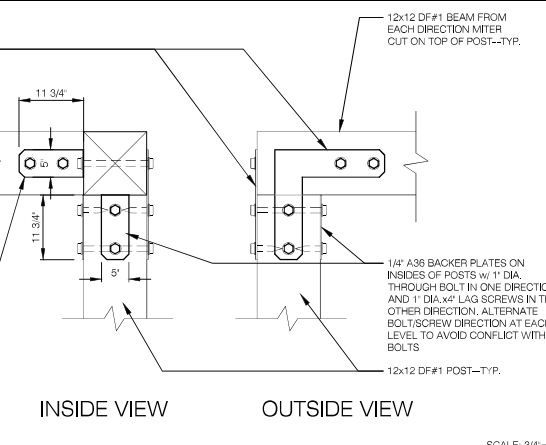

18 KNEE BRACE TO TRUSS

**Land & Structure**  
SURVEYING | ENGINEERING | DESIGN

105 SOUTH STEWART STREET, SONOMA, CALIFORNIA 95370 | 209.532.5173 | F. 209.532.6220

REVISIONS:

rev	date	description

OWNER INFORMATION:  
T.H.C.S.D.  
P.O. Box 649  
Twain Harte CA 95383  
Tom Trott G.M.  
(209) 586-3172

SITE INFORMATION:  
Meadow Drive  
Twain Harte CA 95383  
APN# 049-132-019

PROJECT INFORMATION:  
A Pavilion Plan for:  
**Twain Harte Comm. Serv. Dist.**  
Meadow Drive  
Twain Harte CA 95383

ENGINEER OF RECORD:  
  
Kevin Driscoll  
06-06-23

ISSUE DATE: 6-6-23  
DRAWN BY: KTQ  
CHECKED BY: ZPG  
SCALE: 1/4"=1'-0"  
DRAWING: pavilion  
PROJECT NO: 22-07.11  
SHEET: 5 OF 5

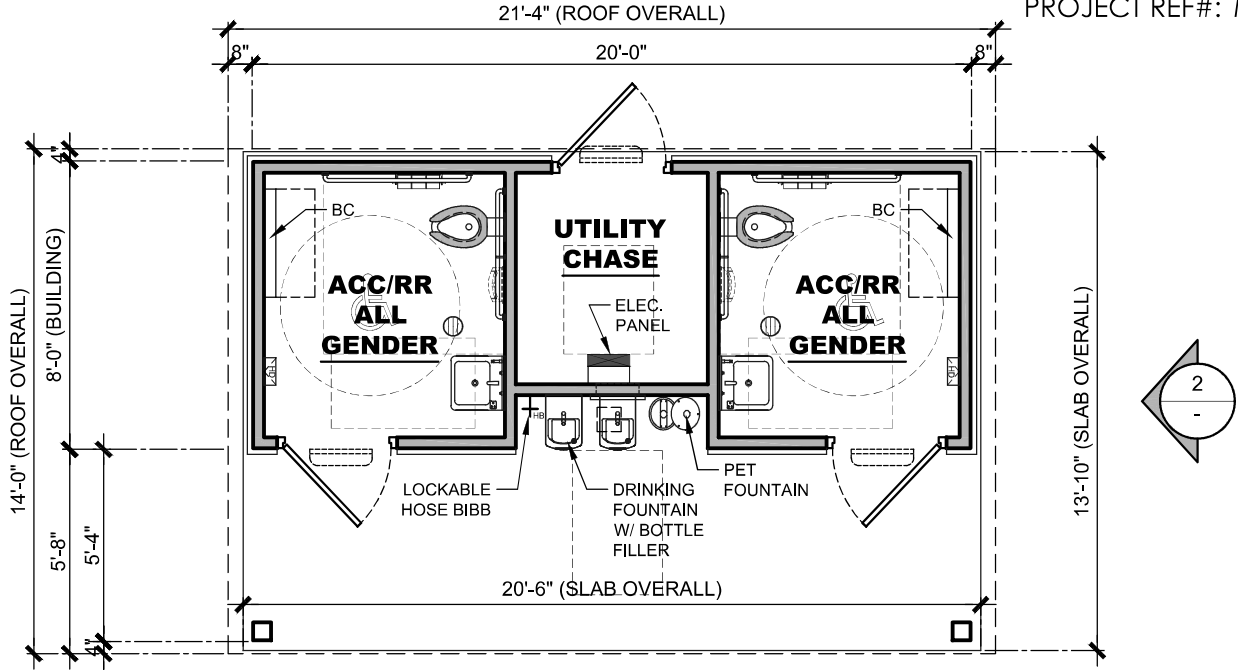

**FLOOR PLAN**  
SCALE: 3/16"=1'-0"

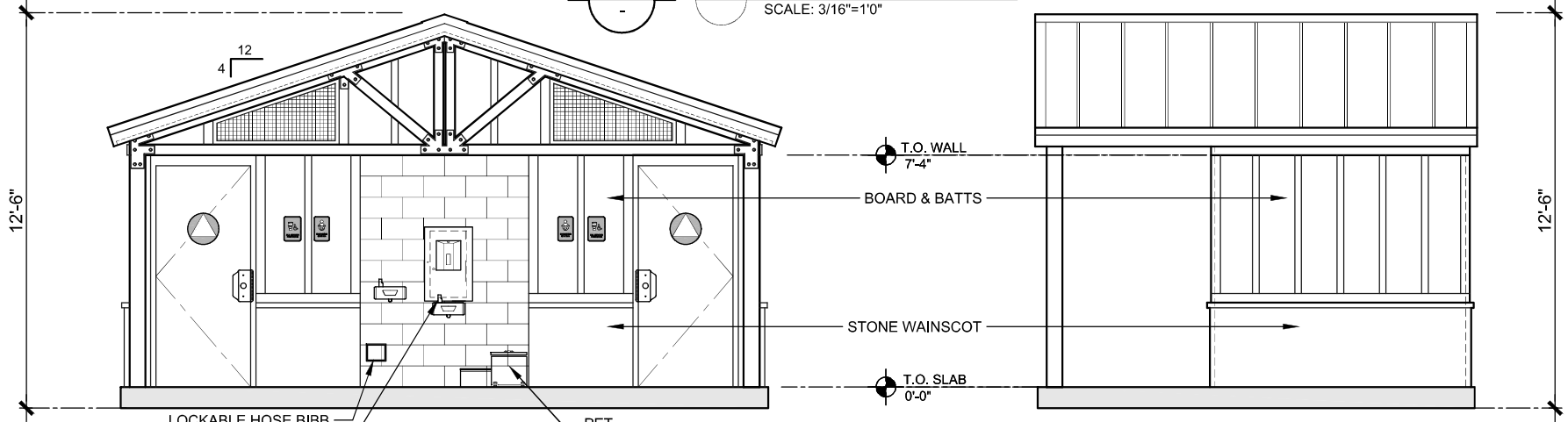

**ELEVATION 1**  
SCALE: 3/16"=1'-0"

**ELEVATION 2**  
SCALE: 3/16"=1'-0"

 <b>PUBLIC RESTROOM COMPANY</b> Building Better Places To Go. <sup>SM</sup>	COPYRIGHT 2023, PUBLIC RESTROOM COMPANY THIS MATERIAL IS THE EXCLUSIVE PROPERTY OF PUBLIC RESTROOM COMPANY AND SHALL NOT BE REPRODUCED, USED, OR DISCLOSED TO OTHERS EXCEPT AS AUTHORIZED BY THE WRITTEN PERMISSION OF PUBLIC RESTROOM COMPANY.	BUILDING TYPE:	<b>RESTROOM BUILDING 'A'</b>	REVISION #	-	REVISION DATE:	-	SHEET#	-
		PROJECT:	<b>TWAIN HARTE MEADOWS TWAIN HARTE, CA</b>	PROJECT #:	<b>11613A</b>	START DATE:	<b>4/25/2023</b>	MAX. PERSON / HOUR:	<b>90 S</b>
Ph: 888-888-2060   Fax: 888-888-1448		~NOT FOR CONSTRUCTION ~ PRELIMINARY DESIGN DRAWING ONLY ~ DO NOT SCALE, DIMENSIONS PRESIDE		DRAWN BY: EOR					

## OWNER / GENERAL CONTRACTOR AND PUBLIC RESTROOM COMPANY RESPONSIBILITIES

### PUBLIC RESTROOM COMPANY RESPONSIBILITIES:

1. PROVIDE FULL ARCHITECTURAL PLANS AND ENGINEERING CALCULATIONS, STAMPED BY STATE GOVERNING AGENCY SUITABLE FOR GENERAL CONTRACTOR TO FILE FOR REQUIRED BUILDING PERMIT.
2. FURNISH AND INSTALL UNDERGROUND UTILITIES UNDER SLAB (INCLUDING TRENCHING) EXTENDING 6 FEET MAX. BEYOND THE BUILDING LINE, MIN. OF 24" - MAX OF 36" BELOW GRADE.
3. FURNISH AND INSTALL SLAB TO FOUNDATION ANCHORS PER DETAILS INCLUDED HEREIN. APPLICABLE ONLY TO BUILDINGS WITH FOUNDATIONS.

### GENERAL NOTES:

1. THE DIFFERENCE IN THE ELEVATION BETWEEN THE FINISH FLOOR OF THE BUILDING AT EXTERIOR DOORS AND THE SIDEWALK OUTSIDE IS 1/4" MAX. PRC RECOMMENDS SIDEWALK TO BE FLUSH WITH FINISH FLOOR AT ALL DOORS.
2. THE PLAN & DETAILS HEREIN ARE SPECIFIC TO THE BUILDING SIZE AND MODULE CONFIGURATION OF THIS BUILDING MODEL.

### OWNER / GENERAL CONTRACTOR RESPONSIBILITIES:

1. PREPARE BUILDING PAD AND OR FOUNDATION.
2. PROVIDE SITE PLAN & ENGINEERED FOUNDATION PLAN (IF APPLICABLE) AND ATTACH IT TO THE PUBLIC RESTROOM COMPANY'S DEPARTMENT OF HOUSING APPROVED DOCUMENTS AND OBTAIN NECESSARY PERMITS FROM LOCAL JURISDICTION.
3. VERIFY AND SCHEDULE NECESSARY INSPECTIONS WITH LOCAL JURISDICTION FOR SITE PERFORMED WORK BY OTHERS, AND FOR UNDER BUILDING SLAB PLUMBING CONNECTIONS MADE BY PRC.
4. COORDINATE SEWER INVERT ELEVATION WITH THE PUBLIC RESTROOM COMPANY PRIOR TO BUILDING INSTALLATION, VERIFY & COORDINATE LOCATION OF EXISTING UTILITIES INCLUDING WATER METER SIZE, TYPE, AND LOCATION OF EXISTING UTILITIES COMING INTO THE BUILDING SUPPLIED BY PRC
5. MAKE FINAL UTILITY CONNECTIONS (INCLUDING NECESSARY UTILITY BOXES).
6. PREPARE SITE FOR MINIMUM ALLOWABLE SOIL BEARING PRESSURE OF 1,500 psf, WITH SUB-GRADE COMPACTED TO 90% M.D.D.
7. SUPPLY AND STOCK PILE REQUIRED QUANTITY OF COARSE MASON SAND WITHIN BUILDING PROXIMITY FOR USE BY PRC FOR UTILITY TRENCH BACKFILL.
8. PROJECTS WITH FOOTINGS: PROVIDE SLEEVES IN FOOTINGS ACCORDING TO UTILITY LOCATION PLAN AND PAD / FOUNDATION PLAN DIRECTION.

### GENERAL SITE CONDITION LIABILITY NOTE:

PUBLIC RESTROOM COMPANY (PRC) PROVIDES BUILDING PAD / FOUNDATION PLAN DRAWINGS FOR PLACEMENT OF OUR BUILDING ON SITE FOUNDATIONS / PADS FOR **REFERENCE ONLY**. PRC DRAWINGS DO NOT INCORPORATE SITE DESIGN FOR LOCAL CODES, SOILS CONDITIONS, FOOTING REQUIREMENTS, AND / OR ANY OTHER CONTRIBUTING SITE FACTORS UP TO AN INCLUDING HIGH WATER TABLES. IT IS THE RESPONSIBILITY OF THE OWNER / GENERAL CONTRACTOR TO PROVIDE A PROPER SITE DESIGN TO ACCOMMODATE THE BUILDING AS WELL AS PROVIDE PROPER SITE CRITERIA SO PRC MAY MODEL SEWER, WATER, AND ELECTRICAL DESIGNS WITHIN THE BUILDING. OUR BUILDING DESIGN INCLUDES AN 8" THICK REINFORCED CONCRETE SLAB AND ASSUMES FULL SLAB BEARING ON SOILS WITH A MINIMUM OF 1500 PSF BEARING CAPACITY. OUR BUILDING DESIGNS SURCHARGE THE SOIL BENEATH THE MAT SLAB AT APPROXIMATE 208 PSF. ANY BUILDING FOUNDATION IN ADDITION TO THE INTEGRAL MAT SLAB ARE SHOWN FOR **REFERENCE ONLY** AND SHOULD BE VERIFIED BY A LICENSED SOILS ENGINEER TO CONFORM WITH REQUIRED CODES. **PRC ASSUMES NO LIABILITY FOR THE OWNER OR GENERAL CONTRACTOR ACCEPTANCE OF THESE TYPICAL DRAWINGS WITHOUT VERIFICATION BY A LICENSED SOILS / FOUNDATION ENGINEER.**



COPYRIGHT 2021, PUBLIC RESTROOM COMPANY THIS MATERIAL IS THE EXCLUSIVE PROPERTY OF PUBLIC RESTROOM COMPANY AND SHALL NOT BE REPRODUCED, USED, OR DISCLOSED TO OTHERS EXCEPT AS AUTHORIZED BY THE WRITTEN PERMISSION OF PUBLIC RESTROOM COMPANY.

BUILDING TYPE:

**RESTROOM BUILDING**

PROJECT:

-

DATE: - DRAWN BY:

PROJECT #: -

SHEET:

**FD-1**

1 OF 4

~NOT FOR CONSTRUCTION ~ PRELIMINARY DESIGN DRAWING ONLY ~ DO NOT SCALE, DIMENSIONS PRESIDE

**NOTES:**

1. BOTTOM OF PRE-FAB BLDG. MANUFACTURERS SLAB IS DEAD FLAT. TOP OF FOOTINGS & COMPACTED BACK FILL MUST BE DEAD LEVEL. POUR FOOTING WITH LASER TRANSIT TO VERIFY TOP OF FOOTING. IF SHIM PLATES ARE REQUIRED A CHANGE ORDER IS REQUIRED.
2. REQUIRED ALLOWABLE SOIL BEARING PRESSURE = 1500 PSF; FIELD VERIFIED BY OTHERS

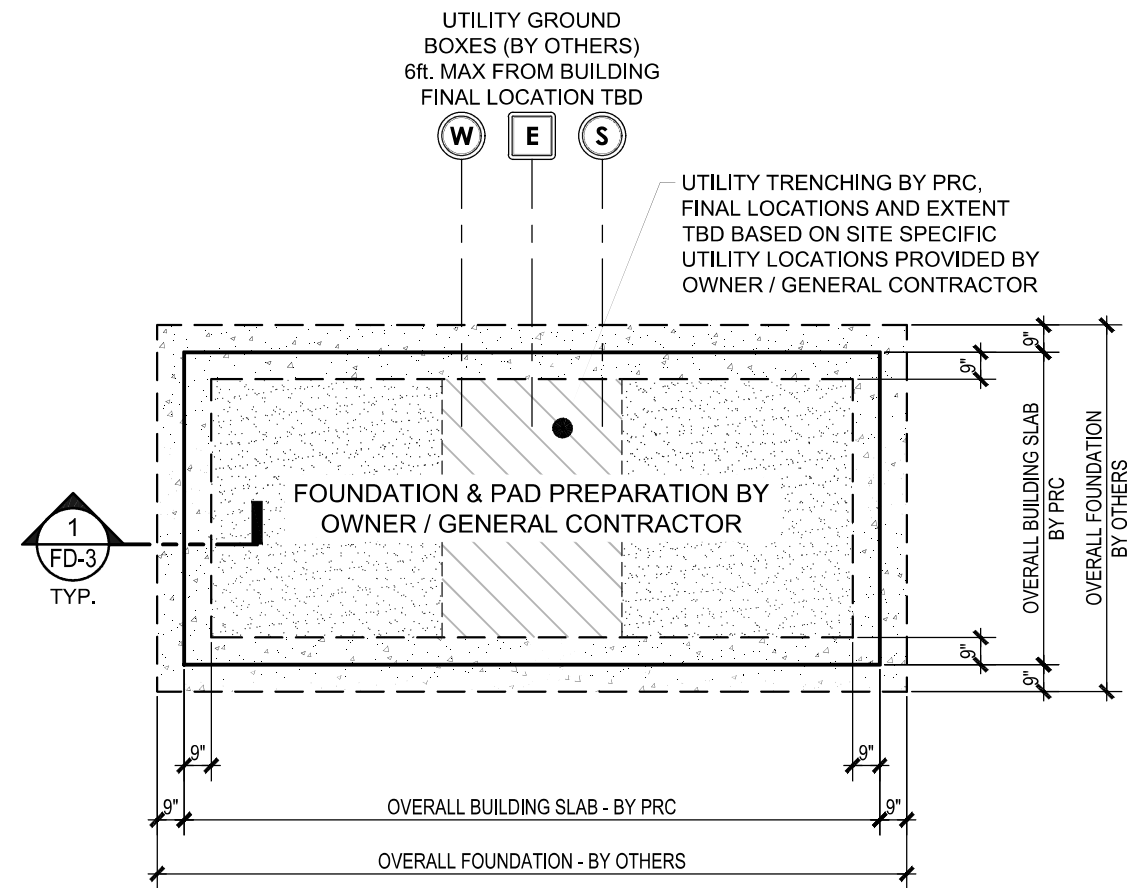

1  
FD-2

**EXAMPLE FOUNDATION / PAD PREPARATION PLAN**  
SCALE: NOT TO SCALE

EXAMPLE FOR REFERENCE ONLY



COPYRIGHT 2021, PUBLIC RESTROOM COMPANY THIS MATERIAL IS THE EXCLUSIVE PROPERTY OF PUBLIC RESTROOM COMPANY AND SHALL NOT BE REPRODUCED, USED, OR DISCLOSED TO OTHERS EXCEPT AS AUTHORIZED BY THE WRITTEN PERMISSION OF PUBLIC RESTROOM COMPANY.

BUILDING TYPE:

**RESTROOM BUILDING**

PROJECT:

-

DATE: -

DRAWN BY: -

PROJECT #: -

SHEET:

**FD-2**

2 OF 4

-NOT FOR CONSTRUCTION ~ PRELIMINARY DESIGN DRAWING ONLY ~ DO NOT SCALE, DIMENSIONS PRESIDE

**NOTES:**

1. BOTTOM OF PRE-FAB BLDG. MANUFACTURERS SLAB IS DEAD FLAT. TOP OF FOOTINGS & COMPACTED BACK FILL MUST BE DEAD LEVEL. POUR FOOTING WITH LASER TRANSIT TO VERIFY TOP OF FOOTING. IF SHIM PLATES ARE REQUIRED A CHANGE ORDER IS REQUIRED.

2. REQUIRED ALLOWABLE SOIL BEARING PRESSURE = 1500 PSF; FIELD VERIFIED BY OTHERS

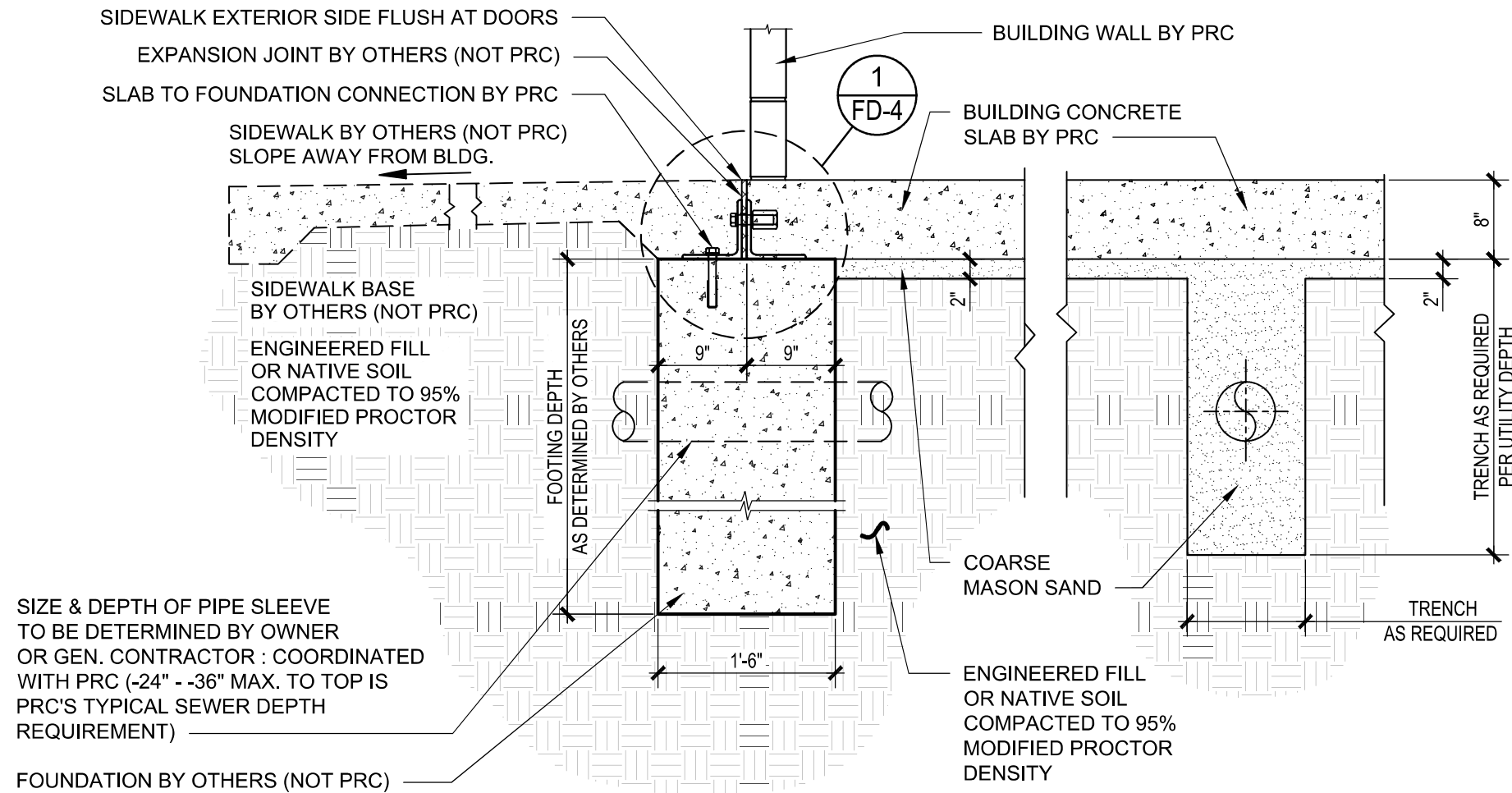

SIZE & DEPTH OF PIPE SLEEVE TO BE DETERMINED BY OWNER OR GEN. CONTRACTOR : COORDINATED WITH PRC (-24" - -36" MAX. TO TOP IS PRC'S TYPICAL SEWER DEPTH REQUIREMENT)

FOUNDATION BY OTHERS (NOT PRC)

1  
FD-3

**TYPICAL FOUNDATION SECTION DETAIL**

SCALE: NOT TO SCALE



COPYRIGHT 2021, PUBLIC RESTROOM COMPANY THIS MATERIAL IS THE EXCLUSIVE PROPERTY OF PUBLIC RESTROOM COMPANY AND SHALL NOT BE REPRODUCED, USED, OR DISCLOSED TO OTHERS EXCEPT AS AUTHORIZED BY THE WRITTEN PERMISSION OF PUBLIC RESTROOM COMPANY.

BUILDING TYPE:

**RESTROOM BUILDING**

PROJECT:

DATE: - DRAWN BY:

PROJECT #: -

SHEET:

**FD-3**

3 OF 4

-NOT FOR CONSTRUCTION ~ PRELIMINARY DESIGN DRAWING ONLY ~ DO NOT SCALE, DIMENSIONS PRESIDE

**NOTE:**  
**QUANTITY AND LOCATIONS OF ANCHORS TO BE DETERMINED BY PRC ENGINEER**

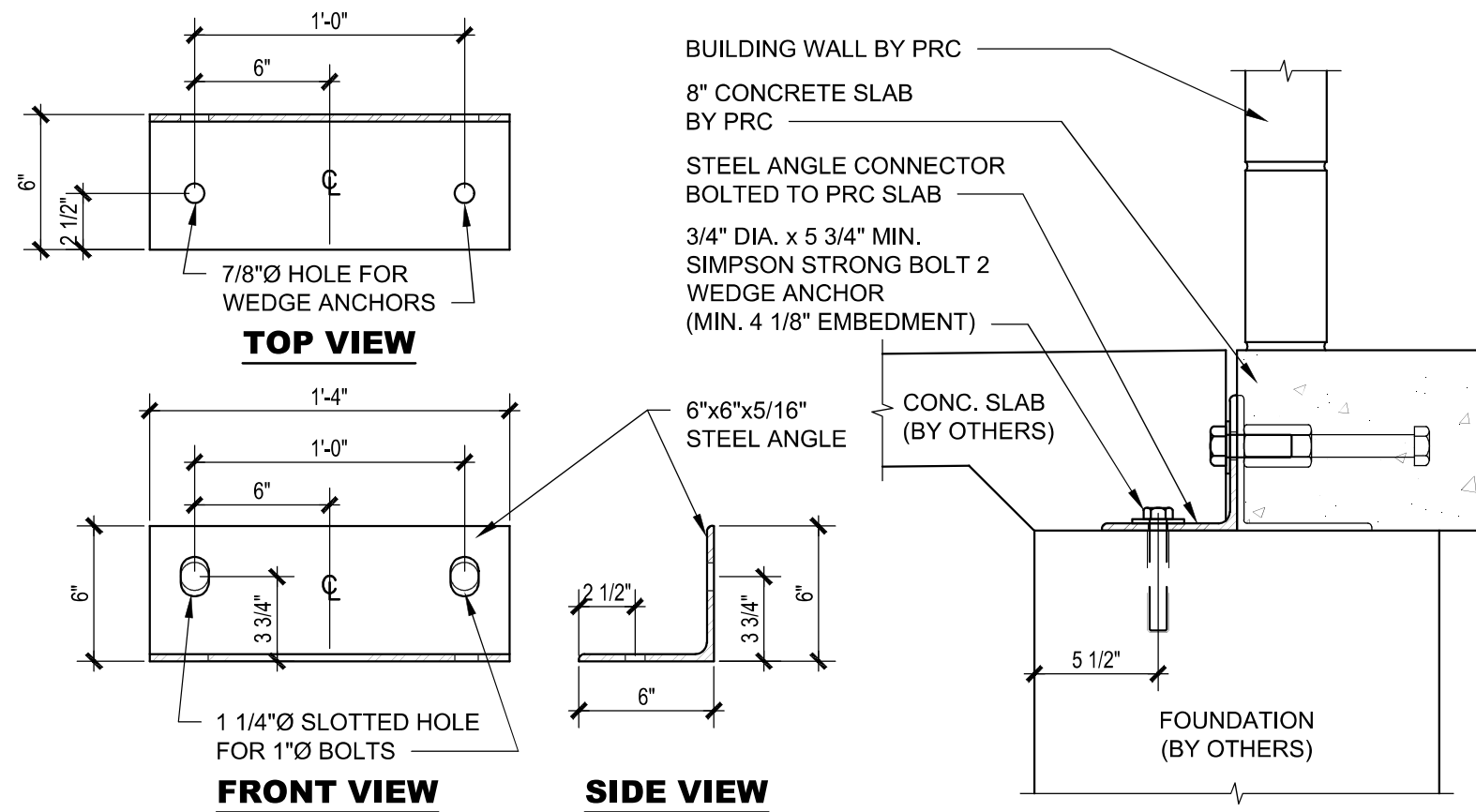

**1** SLAB TO FOUNDATION ANCHOR DETAIL (BY PRC)  
 FD-4 SCALE: NOT TO SCALE



COPYRIGHT 2021, PUBLIC RESTROOM COMPANY THIS MATERIAL IS THE EXCLUSIVE PROPERTY OF PUBLIC RESTROOM COMPANY AND SHALL NOT BE REPRODUCED, USED, OR DISCLOSED TO OTHERS EXCEPT AS AUTHORIZED BY THE WRITTEN PERMISSION OF PUBLIC RESTROOM COMPANY.

BUILDING TYPE: **RESTROOM BUILDING**

PROJECT: -

DATE: - DRAWN BY: -

PROJECT #: - SHEET: **FD-4**

4 OF 4

-NOT FOR CONSTRUCTION ~ PRELIMINARY DESIGN DRAWING ONLY ~ DO NOT SCALE, DIMENSIONS PRESIDE